

S3100A series inverter

General Open-loop Vector Control (IM)

User manual



S3100A series inverter

General Open-loop Vector Control (IM)

User manual

File No. 520031128084

Vision No. V1.4

Filing time 2024-11-29

SAVCH electric provide a full range of technical support for our customers.

All users could contact with the nearest SAVCH office or service center,
also could contact with our headquarters directly.

SAVCH Electric reserves the copyrights and all rights,

Subject to change without further notice.

CONTENT

PREFACE	1
1 SAFETY INSTRUCTIONS	2
1.1 Notes for Operation	2
1.2 Notes for Operation Environment	4
2 HARDWARE DESCRIPTION AND INSTALLATION	5
2.1 Operational Environment	5
2.2 Model Description	6
2.3 Inverter Specifications	7
2.4 Basic Wiring Diagram	15
2.5 External Dimensions	17
2.5.1 Inverter Size	17
2.5.2 External Dimensions of Inverter	18
2.5.3 Multi-Functions Operation Keypad	26
3 KEYPAD DESCRIPTION	28
3.1 Keyboard Description for HCA-OP-A2 / HCA-OP-B2 Digital Operator	28
3.2 Description of Keyboard Operation	30
3.2.1 Parameter Setting	30
3.2.2 Failure Resetting	31
3.2.3 Motor Parameter Self-learning	31
3.2.4 Password Setting	31
3.2.5 Running State	32
3.2.6 Quick Debugging	33
3.3 Preliminary Operation-not Connecting With Motor	34
4 FUNCTION PARAMETERS LIST	36
5 DESCRIPTION OF FUNCTIONAL PARAMETERS	62
00 Basic Functions Parameters	62
01 Motor Control Parameters	70
02 Vector Control Parameters	72
03 V/f Control Parameters	74
04 Input Terminal Parameters	78
05 Multi-Speed, Simple PLC Control	87
06 Output Terminal Parameters	91
07 Start and Stop Control Parameters	95
08 Man-machine Interface Parameters	99
09 Accessibility Parameters	103
10 PID Control Parameters	112

11 Fault and Protection Parameters	116
12 Serial Communication Parameters	123
13 Wobble Frequency Counting Parameters	130
16 Parameter management	132
17 Torque Control Parameters	132
22 Control Optimization Parameters	134
99 Monitoring Parameters	135
6 TROUBLE SHOOTING	137
6.1 Failures & Failure Elimination	137
6.2 General Troubleshooting Method	140
7 MAINTENANCE AND AMBIENT ELEMENTS	141
7.1 Braking Resistor Selection Guide	143
7.2 Breaker, Cable and Contactor Specifications List	147
7.3 Input/Output AC Reactor and DC Reactor Specifications	148
7.4 Input/Output Filter Specifications	150

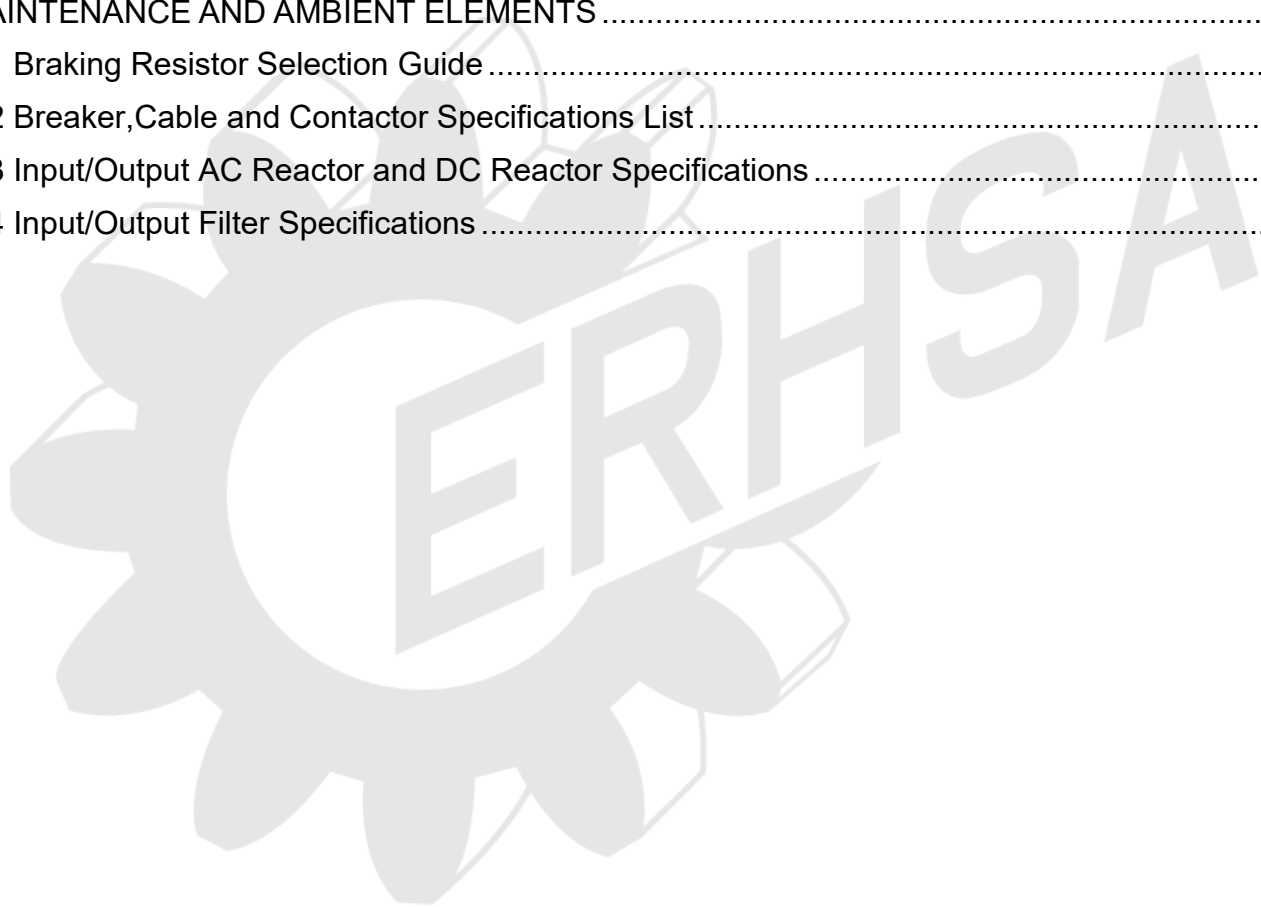



Thank you for choosing SAVCH inverter! This instruction manual, which includes operation descriptions and notes for maintenance, shall be delivered to the end-user.

For safety running and effective operation, this instruction manual shall be read thoroughly prior to use, which shall also be preserved for later use. Provided problems occur and solution is not provided in this instruction manual, contact your SAVCH ELECTRIC representative or contact with our company directly. Our professional technicians will serve for you actively. And please continue to adopt products of SAVCH, give valuable opinion and advice.

1. Reading Instructions

Symbols of " DANGER" and " CAUTION" in the manual indicates that, for safety running or maintenance of inverters or other electrical products, attention shall be attached during delivering, installation, operation and checks for the inverter. And these notes shall be applied for a better and safer operation.

 DANGER	If not used correctly, personnel damage even death may be caused.
 CAUTION	If not used correctly, serious damage to inverter or machine may be resulted.

DANGER

- Never connect wires while power on. Do not check components or signal for circuit board during operation.
- Do not dismantle or change inner wire, circuit or components unnecessarily.
- Make sure grounding terminals are correctly grounded. 220V level: Grounding III, 440V special grounding.

CAUTION

- Do not perform a withstand voltage test for components of inverter, it can cause semi-conductor components to be damaged by high voltage.
- Never connect the output terminals U, V, W to AC power supply.
- IC of CMOS on control circuit of the inverter shall be damaged by electrostatic influence. Do not touch main circuit board.

2. Products Receiving

All products have been performed with strict test and inspection. After receiving the inverters, the following checks shall be performed.

- To check that SAVCH inverter, an instruction manual and a cover is inside of the package
- To check whether model number correspond with model and capacity your purchase order.
- To check whether there are damaged parts during transportation and delivering. If there are, do not connect with power supply.
- If any of the above checkpoints are not satisfactory, contact your SAVCH ELECTRIC representative for a quick resolution.

1 SAFETY INSTRUCTIONS

1.1 Notes for Operation

Before wiring

 **CAUTION**

Specification of applying power supply shall correspond to input voltage of the inverter.

 **DANGER**

Main circuit terminals must be correct, R/L1, S/L2 and T/L3 is input terminals and it's forbidden to use mixing with U/T1, V/T2 and W/T3. Failure to observe this may cause the inverter damaged.

Installation

 **DANGER**

- When handling the inverter, do not draw front cover directly but handle it by the heat sink to prevent the cover from falling off and to avoid the falling of the inverter and causing personal injury or damage to the inverter.
- Install the inverter on a base made of metal or other non-flammable material, Do not place flammable object nearby to prevent fires.
- If several inverters are installed in a electric cabinet, add extra cooling fan to keep the temperature lower than 40 °C to prevent over-heating or fire.
- Operator shall be dismantled or refitted after power supply is off. Fixed operator shall be processed as diagram shows.
- Confirm whether the input voltage is identical with the voltage in the nameplate on the right side of the inverter, Otherwise the malfunction could happen.

Operation

 **DANGER**

- Never put in or take off the motor during operation, otherwise over-current even over burning the main circuit of the inverter may happen.
- Do not remove the cover while current is flowing. Failure to observe this may result in electrical shock to personnel.
- When auto-restart function is set, do not approach the machine since motor can be reset suddenly after being stopped.
- As STOP key can be invalid unless being set, which is different from the emergency stop key, please pay attention to it.

⚠ CAUTION

- Never touch heat sink or discharging resistor since temperature may be very high.
- Since it is easy to change running speed from low to a high speed, verify safe working range of motor and machine before running.
- Pay attention to relative equipments before using the brake unit.
- Do not check signals during running.
- All parameters of the inverter have been preset at the factory according to line frequency. Do not change the settings value at will.
- Please confirm that the power is turned off and wait for 10 minutes before disassembly or inspection.

Check and maintenance

⚠ CAUTION

- Ambient temperature for operating the inverter shall be -10°C to $+40^{\circ}\text{C}$ and 90%RH no condensation.
- After removing the cover, ambient temperature for operating the inverter shall be -10°C to $+50^{\circ}\text{C}$ and 95%RH no condensation, the ambient environment must be without drips of water or metal dust. If it was, the cover shall be set and check ambient temperature is within -10°C to $+40^{\circ}\text{C}$.

Disposal precaution

⚠ CAUTION

- Explosion may occur when burning the electrolytic capacitor of the main circuit and printing plate. Toxic gas may be generated when burning control panel and other plastic fittings.
- It shall be treated as Industrial waste when disposing of it

1.2 Notes for Operation Environment

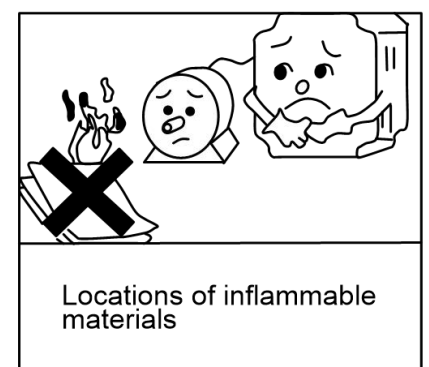
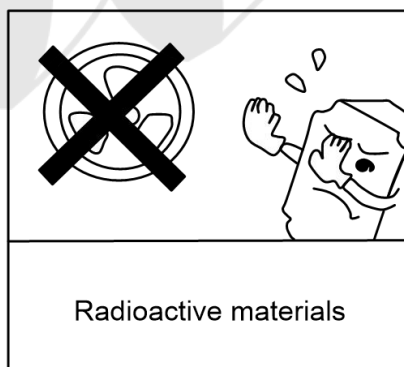
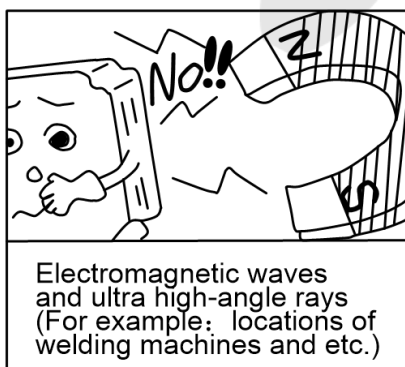
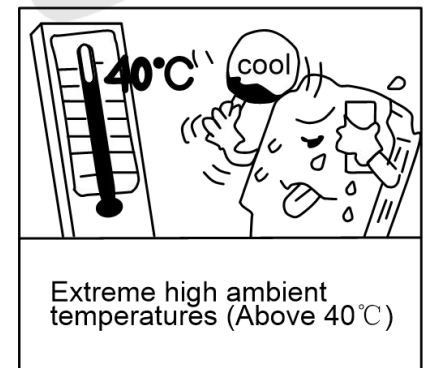
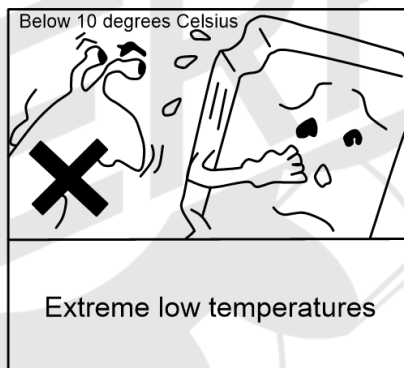
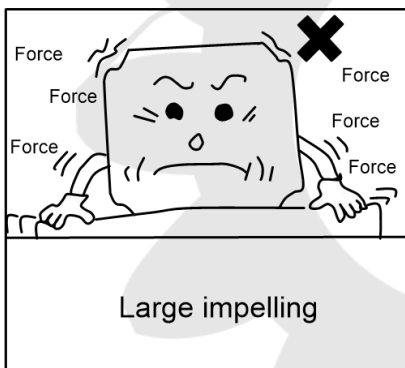
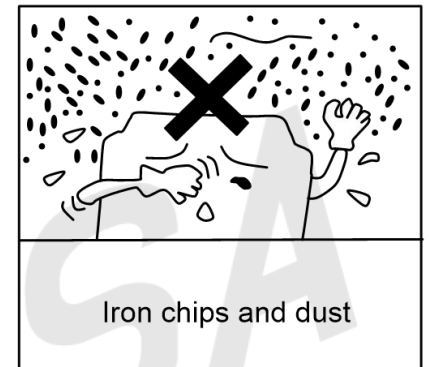
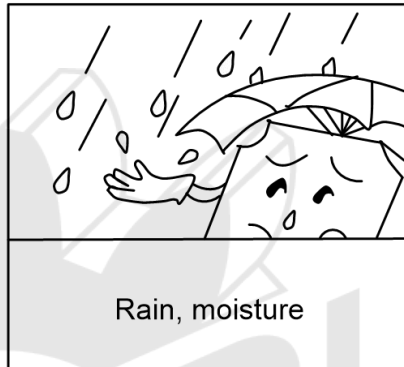
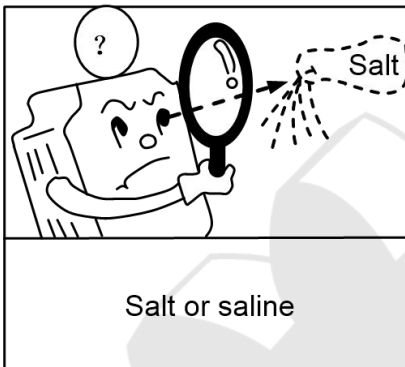
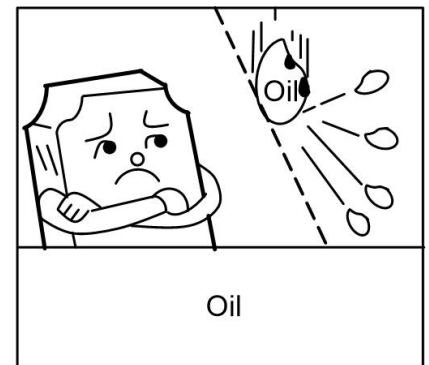
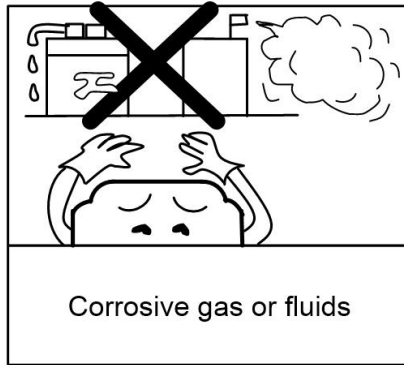
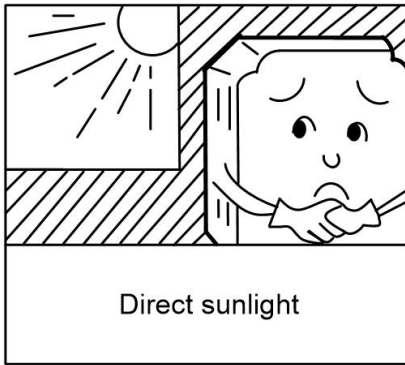

2 HARDWARE DESCRIPTION AND INSTALLATION

2.1 Operational Environment

Since operation environment can directly influence functions and operation life, to ensure proper performance and long operation, follow the recommendations below when choosing allocation for installing the inverter:

- Use only with the ambient temperature range: -10°C to $+40^{\circ}\text{C}$; -10°C to $+50^{\circ}\text{C}$ applicable when dust cover is removed.
- Rain, moisture
- Direct sunlight. (Avoid using outdoors)
- Corrosion of oil sprays or salt
- Corrosive fluid and methane
- Dust or batting and metallic particles in the air
- Radioactive materials and inflammable materials
- Electromagnetic interference (Avoid using together with welding machine or dynamic machines.)
- Vibration. (If inverter must be used in this environment, an anti vibration pad is necessary).

Attention shall be attached to clearance of inverters allocated closely. A fan shall be installed to make sure temperature is lower than 40°C

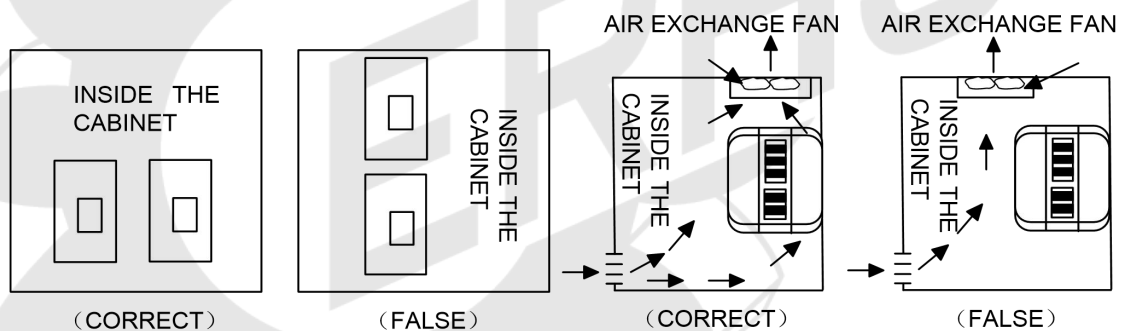

For cooling off, face shall be toward front and upper parts shall be upwards.

Clearance shall meet the following specifications:

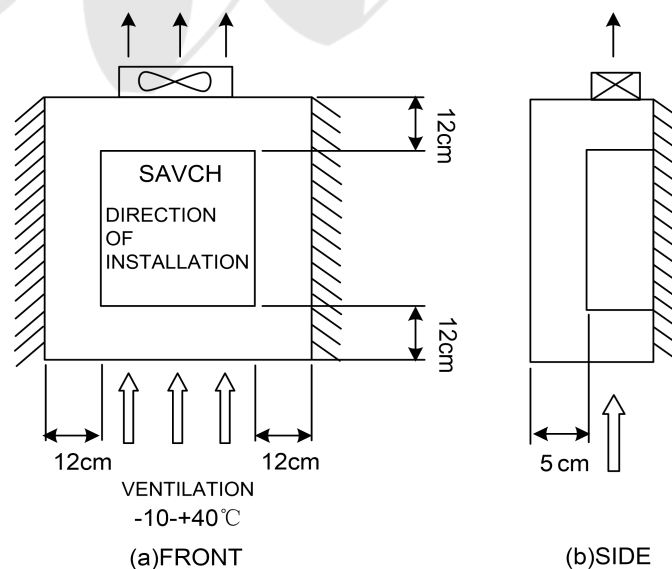

2.2 Model Description



Model → TYPE: S3100A-4T7.5G/11P **CE**

Input power supply Spec → SOURCE: AC 3PH 380~460V 50/60Hz

Output power supply Spec → OUTPUT: 3PH 0~460V 13kVA 17/21.7A

Output frequency → FREQUENCY RANGE: 0~500Hz

S/N:  NJ301938000037

Designed by Savch Electric
SAVCH ELECTRIC CO.,LTD.

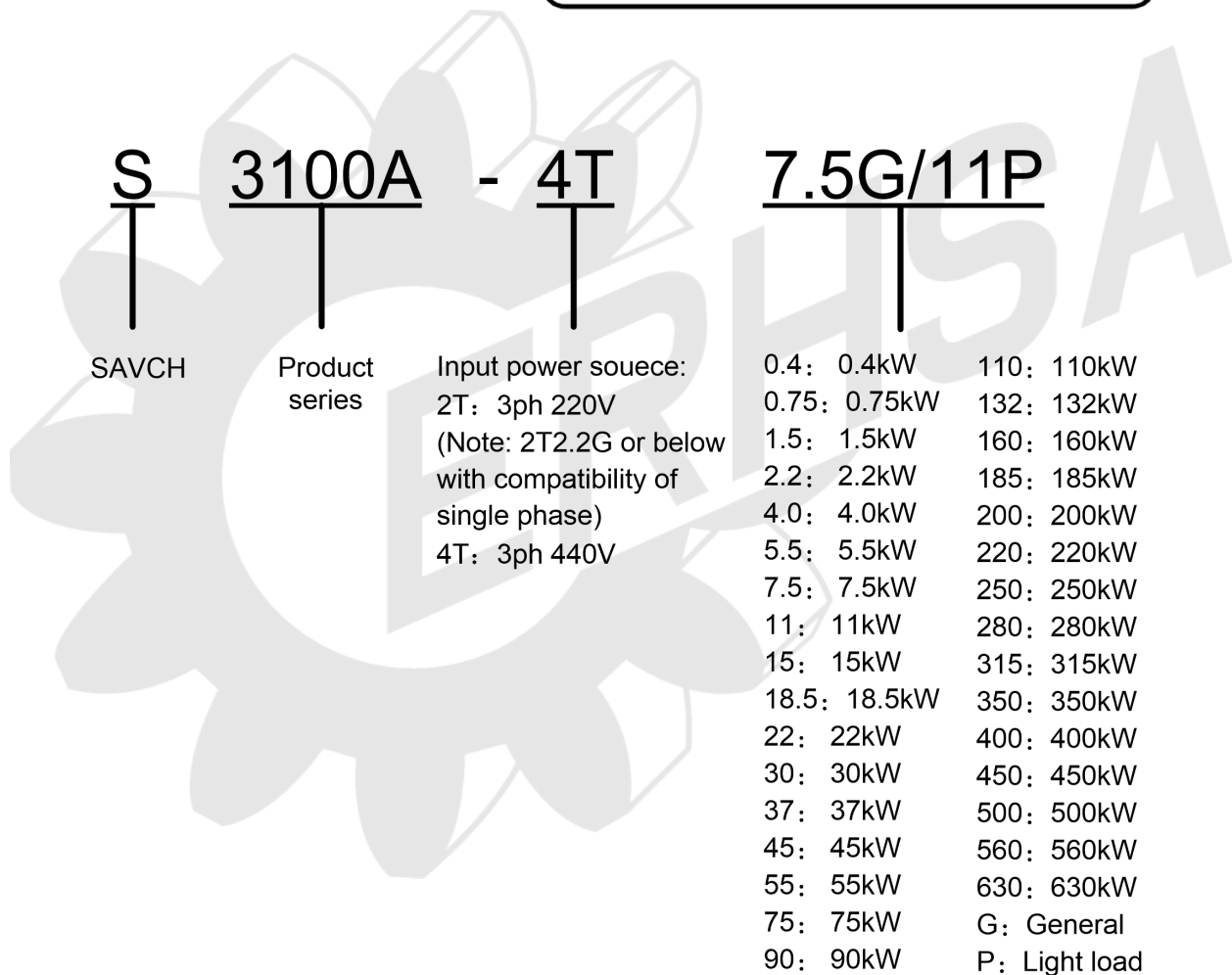
S	3100A	- 4T		
SAVCH	Product series	Input power souece: 2T: 3ph 220V (Note: 2T2.2G or below with compatibility of single phase) 4T: 3ph 440V		
			7.5G/11P	
			0.4: 0.4kW	110: 110kW
			0.75: 0.75kW	132: 132kW
			1.5: 1.5kW	160: 160kW
			2.2: 2.2kW	185: 185kW
			4.0: 4.0kW	200: 200kW
			5.5: 5.5kW	220: 220kW
			7.5: 7.5kW	250: 250kW
			11: 11kW	280: 280kW
			15: 15kW	315: 315kW
			18.5: 18.5kW	350: 350kW
			22: 22kW	400: 400kW
			30: 30kW	450: 450kW
			37: 37kW	500: 500kW
			45: 45kW	560: 560kW
			55: 55kW	630: 630kW
			75: 75kW	G: General
			90: 90kW	P: Light load

2.3 Inverter Specifications

2.3.1 Standard Specifications

220V single phase/Three phase Series

Item		specification							
S3100A-2T□□□G		0.4	0.75	1.5	2.2	4.0	5.5	7.5	
Output	Maximum applicable motor output power(kW)	0.4	0.75	1.5	2.2	4.0	5.5	7.5	
	Maximum applicable motor output power(HP)	0.5	1	2	3	5.4	7.4	10	
	Output rated capacity(kVA)	1.1	1.5	2.7	3.7	6.5	9.5	12.2	
	Output rated current(A)	2.3	4.0	7.0	9.6	17.0	25	32	
	Output frequency range	0~500Hz							
	Overload capacity	150%-60s							
	Max output voltage	Same to input voltage							
Input	Voltage,Frequency	200~240V. 50/60Hz							
	Voltage frequency variations	Voltage:±15% frequency:±5%							
	Input current(A)	Single phase	5.4	8.2	14.2	23	No single phase input		
		Three phase	3.1	5.0	7.7	11.1	22.2	31.5	42.7
Cooling method		Fan cooling							

Item		specification								
S3100A-2T□□□G		11	15	18.5	22	30	37	45	55	
Output	Maximum applicable motor output power(kW)	11	15	18.5	22	30	37	45	55	
	Maximum applicable motor output power(HP)	15	20	25	30	40	50	60	75	
	Output rated capacity(kVA)	17.1	22.8	28	34.6	42.7	57.1	67	80	
	Output rated current(A)	45	60	75	91	112	150	176	210	
	Output frequency range	0~500Hz								
	Overload capacity	150%-60s								
	Max output voltage	Same to input voltage								
Input	Voltage,Frequency	200~240V. 50/60Hz								
	Voltage frequency variations	Voltage:±15% frequency:±5%								
	Input current(A)	Single phase	No single phase input							
		Three phase	46.5	62	76	92	113	157	180	214
Cooling method		Fan cooling								

Three phase 440V Series

Item		Specification									
S3100A-4T□□□G/P		0.75	1.5	2.2	4.0	5.5	7.5	11	15	18.5	22
Output	Maximum applicable motor output power(kW)	0.75	1.5	2.2	4.0	5.5	7.5	11	15	18.5	22
	Maximum applicable motor output power(HP)	1	2	3	5.4	7.4	10	14.7	20	24.7	29.4
	Output rated capacity(kVA)	1.9	2.9	3.9	6.9	9.9	13	19.1	24.4	28.2	34.3
	Output rated current(A)	2.5 (3.2)	3.8 (4.7)	5.1 (6.5)	9 (11.8)	13 (15)	17 (21.7)	25 (28.5)	32 (35.4)	37 (42)	45 (60)
	Output frequency range	0~500Hz									
	Overload capacity	G type:150%-60seconds					P type:120%-60seconds				
	Max output voltage	Same to input voltage									
Input	Phase,voltage,Frequency	Three phase·380-460V ·50/60Hz									
	Voltage frequency variations	Voltage:±15% Frequency:±5%									
	Input current(A)	3.4	5.0	5.8	10.5	15	20.5	26	35	38	46
Cooling method		Fan cooling									

Item		Specification									
S3100A-4T□□□G/P		30	37	45	55	75	90	110	132	160	
Output	Maximum applicable motor output power(kW)	30	37	45	55	75	90	110	132	160	
	Maximum applicable motor output power(HP)	40	50	60	74	100	120	147	176	214	
	Output rated capacity(kVA)	45.7	57.1	68.6	83.8	114.3	134	160	191	229	
	Output rated current(A)	60 (75)	75 (85)	90 (110)	110 (152)	152 (176)	176 (210)	210 (253)	253 (304)	304 (340)	
	Output frequency range	0~500Hz									
	Overload capacity	G type:150%-60seconds					P type:120%-60seconds				
	Max output voltage	same to input voltage									
Input	Phase,voltage,Frequency	Three phase·380-460V ·50/60Hz									
	Voltage frequency variations	Voltage:±15% Frequency:±5%									
	Input current(A)	62	76	92	113	157	180	214	256	308	
Cooling method		Fan cooling									

Three phase 440V Series

Item		Specification							
S3100A-4T□□□G/P		185	200	220	250	280	315	355	400
Output	Maximum applicable motor output power(kW)	185	200	220	250	280	315	355	400
	Maximum applicable motor output power(HP)	247	267	294	334	374	420	470	530
	Output rated capacity(kVA)	259	290	316	358	396	445	500	565
	Output rated current(A)	340 (377)	377 (426)	426 (465)	465 (520)	520 (585)	585 (650)	650 (725)	725 (820)
	Output frequency range	0~500Hz							
	Overload capacity	G type:150%-60seconds				P type:120%-60seconds			
	Max output voltage	same to input voltage							
Input	Phase,voltage,Frequency	Three phase·380-460V ·50/60Hz							
	Voltage frequency variations	Voltage:±15% Frequency:±5%							
	Input current(A)	345	382	430	470	525	590	655	730
Cooling method		Fan cooling							

Item		Specification			
S3100A-4T□□□G/P		450	500	560	630
Output	Maximum applicable motor output power(kW)	450	500	560	630
	Maximum applicable motor output power(HP)	600	660	755	840
	Output rated capacity(kVA)	630	700	785	871
	Output rated current(A)	820 (860)	860	1040	1180
	Output frequency range	0~500Hz			
	Overload capacity	G type:150%-60seconds		P type:120%-60seconds	
	Max output voltage	same to input voltage			
Input	Phase,voltage,Frequency	Three phase·380-460V ·50/60Hz			
	Voltage frequency variations	Voltage:±15% Frequency:±5%			
	Input current(A)	825	865	1045	1185
Cooling method		Fan cooling			

2.3.2 General specification

Item		Detailed information	
Control characteristic	Control mode	V/f control, open loop vector control, torque control	
	range of output frequency	0~500.00Hz(V/f highest 3200.0Hz)	
	Frequency setting resolution	0.01 Hz	
	Output Frequency setting resolution	0.01 Hz	
	PWM carrier frequency	adjust from 0.5kHz to 16kHz	
	Torque boost	open loop vector control(SVC):G type:0.5Hz/150%, P type:0.5 Hz/120%	
	V/f curve	Three types:line, multi-point. Nth power V/f curve (1.2th power,1.4 th power,1.6 th power,1.8 th power,2th power)	
	V/f separation	two types:full separation, semi-separation	
	Jump frequency	adjust from 0.1hz to 500.00hz	
	Acceleration/deceleration time	0.00 to 65000 seconds (4-stage acceleration/deceleration time is set independently), linear or S-curve acceleration/deceleration mode.	
	Over current stall prevention level	Can be set according to the motor load characteristics with 100~200% of the rated current of the driver	
	DC brake	When stopping, it can be operated from 0.00 to the maximum operating frequency, and the braking current is 0 to 100% of the rated current; Start time 0-100.0 seconds, stop time 0-100.0 seconds.	
	Brake torque	20% (external optional brake resistor can reach 125%) (1-50HP brake transistor built-in, 60HP and above can be connected to the external brake unit module)	
Speed ratio	open loop vector control:1:100		
Operation characteristic	Frequency setting signal	bit operation board	set by  
		external terminal	0-10VDC, 4-20mADC, Serial communication(RS485)
	Operation signal	bit operation board	Available to be operated by RUN,STOP,JOG keys
		external terminal	2-wire / 3-wire operation, jog operation, serial communication (RS485)
	Input terminal of multi-function	Forward and reverse running, three-wire operation control,Forward and reverse jog running, free stop, reset fault, running pause,external fault input,increment/decrement frequency terminal setting,16-segment preset speed switching,acceleration/deceleration time switching,frequency source switching, running command switching, PID control, PLC status reset, pause swing frequency, reset swing frequency, prohibit acceleration and deceleration, disable torque control, calculator function, length count, frequency increase and decrease setting clear, high speed pulse frequency , stop DC braking, frequency modification enable, speed control and torque control switching, clear running time of this time.	
	Output terminal of multi-function	Inverter operation, fault output, frequency level detection FDT output, frequency arrival, zero speed operation, overload pre-alarm, count value arrival, length arrival, PLC cycle completion, cumulative running time arrival, frequency limitation, torque limit Ready to run, AVI1>AVI2, upper	

Item		Detailed information
		limit frequency arrival, lower limit frequency arrival (operation related), undervoltage status output, communication setting, cumulative power-on time arrival, frequency arrival output, timing arrival output, offload, reverse In operation, the zero current state, the module temperature reaches, the output current exceeds the limit, the lower limit frequency arrives (the stop is also output), the alarm output (continues to run), and the running time arrives.
	Analog signal output	Corresponding to the actual output frequency, output current, output voltage, etc.
	Fault signal contact	Contact "ON" (one "C" contact relay or two open collector outputs when the AC drive fails)
Inner function		Output frequency upper and lower limit setting, instantaneous power failure restart, abnormal fault restart, speed tracking Simple PLC, multi-speed operation, PID control, timing control Automatic regulated output regulation Abnormal record, parameter lock, parameter factory reset Reverse rotation prohibited, overcurrent stall prevention, overvoltage stall prevention, electronic thermal relay
Protection function		Short circuit protection, acceleration over current, deceleration over current, constant speed over current, acceleration over voltage, deceleration over voltage, constant speed over voltage, bus undervoltage fault, motor overload, inverter overload, over torque protection, loss phase on the input (7.5G/11P and above), loss phase on the output, module overheating, external fault, communication fault, current detection fault, motor self-learning fault, parameter read and write abnormality, inverter hardware abnormality, motor short circuit to ground, running time arrival, the power-on time arrives, the load dropped, the PID feedback disconnected, and the fast current limit timeout.
Number of part on keypad		Contains 8 function keys, 5-digit 8-segment LED display, 6 status indicator LED lights, Can set the frequency, display the actual output frequency, output current, user-defined unit Parameter browsing and modification settings and parameter locking, abnormal fault display Executable operation, stop, reset, forward/reverse, jogging
Environment	Operation temperature	-10℃ to +50℃ (+40℃ ~ +50℃ Below 90%RH, No condensation)
	Temperature of stock	-20℃ to +60℃
	Humidity of operation environment	Below 90%RH, No condensation
	Height of installation	No more than 1000m in height, no corrosive gas, liquid, dust
	Vibration	Below 20Hz 9.80665m/s ² (1g), 20~50Hz 5.88m/s ² (0.6g)
	Enclosure	IP20 (Depending on the end customer's installation environment)

Note: The instantaneous power failure compensation time varies due to the inverter capacity. If a long instantaneous power failure time is required, the external "instantaneous power failure compensation device" can be added.

Inverter Using and the Main Circuit Wiring, the Basic Wiring Diagram

Peripheral Equipment Application and Precautions

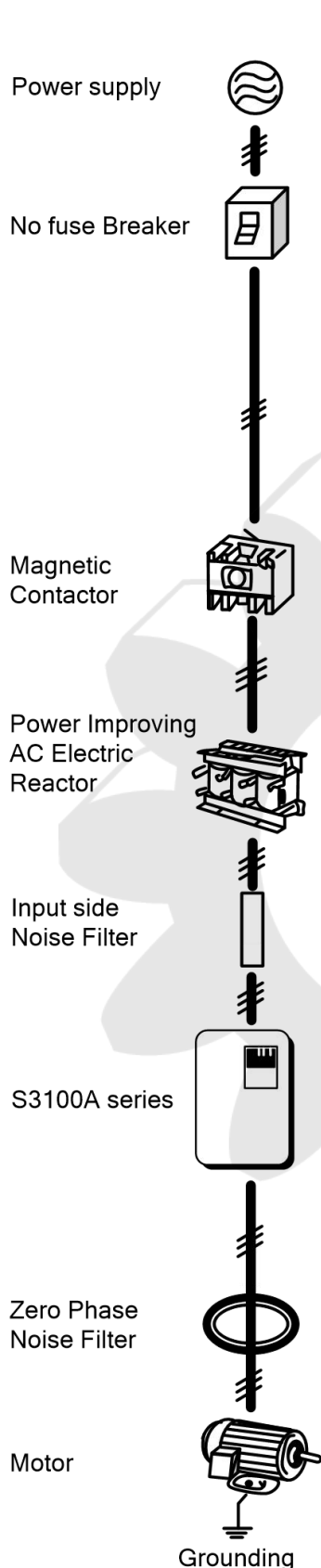

Power:

- Use the power supply in the permissible specifications of the inverter model to avoid damaging the drive.

No fuse circuit breaker(MCCB):

- A non-fuse circuit breaker (MCCB) must be installed between the AC power supply and the inverter, but do not use it as inverter's operation / stop switching function.

- Use a non-fuse circuit breaker (MCCB) that complies with the rated voltage and current rating of the inverter. When the capacity is selected, it is at least 2 times the sum of the rated output current of the inverter (mainly considering 150% of the inverter overload, 1min).

Leakage circuit breaker(RCD/ELCB):

- Please install the leakage circuit breaker, to prevent leakage caused by the malfunction and to protect the safety of the use of personnel;
- Each inverter should use a dedicated circuit breaker whose sensitive current is more than 30mA;
- When using an ordinary circuit breaker, the current sensitivity must be more than 200mA, operation Time must be more than 0.1s.

Electromagnetic contactor:

- Normally, there is no need to add electromagnetic contactor, but it can be used as an external control protection, automatic restart after power failure and other functions, must install electromagnetic contactor.

- When using the brake unit, please connect to the thermal relay contact of the brake unit, close the electromagnetic contactor when overheating;
- Do not use the electromagnetic contactor as the inverter's operation / stop switching function, which will shorten the life of the inverter.

Power Improvement AC Reactor:

- If a large capacity (500KVA or more) is used for the inverter, an excessive peak current may flow into the input side of the inverter, and the rectifier element may be damaged. In this case, the AC reactor can also improve the power factor on the power supply side.

Input side noise filter:

- It is possible to remove the noise from the power supply line into the inverter and to reduce the noise from the inverter to the power supply line.
- When there is an inductive load around the inverter, please ensure to install it.

Inverter:

- Input power terminals R / L1, S / L2, T / L3 are connected without any phase sequence.

- The output terminals U / T1, V / T2, W / T3 are connected to the U / T1, V / T2, W / T3 terminals of the motor. If the inverter is running forward, the motor is reversed. / T2, W / T3 terminal in any two can be adjusted.

- Do not connect output terminals U, V, W to AC power to avoid damage to the inverter.

- Ground terminal should be properly grounded, 220V level: grounding resistance should be below 100 Ω , 440V class: grounding resistance should be 10 Ω or less.

Zero phase filter:

- When you want to reduce the electromagnetic interference caused by the inverter, it is effective in the range of 1MHz ~ 10MHz. The more the number of the motor wires are bypassed, the better.

Install as close to the inverter as possible, suitable for either the input side or output side of the inverter.

Wiring shall be checked whether correct or not. Peripheral wiring shall fulfill the following requirements.

(Warning: Do not use a buzzer of control circuit to check wiring)

(A) Wiring for control circuit power supply must be isolated or far from other high voltage wirings or high current power lines, thus electromagnetic interference can be avoided. See diagrams below:

- Individual power supply bridge for inverter

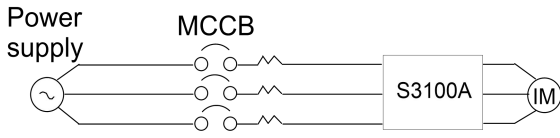

- If inverter power supply circuit is used commonly with other machines, inverter-specialized noise filter or isolating transformer shall be added.

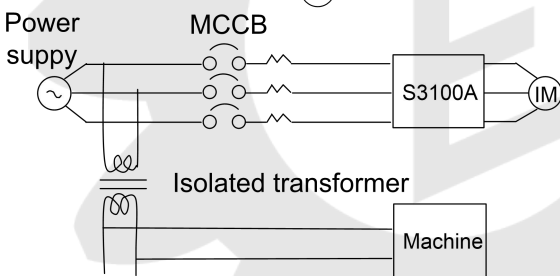
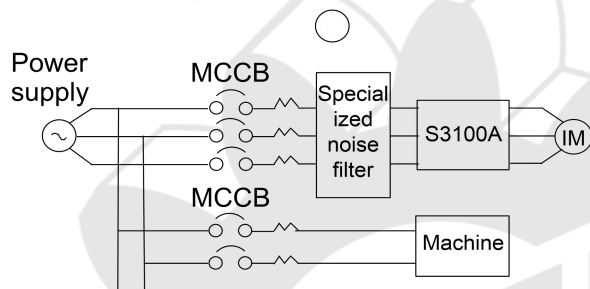

- Good effect may not be received if general use noise filters are applied

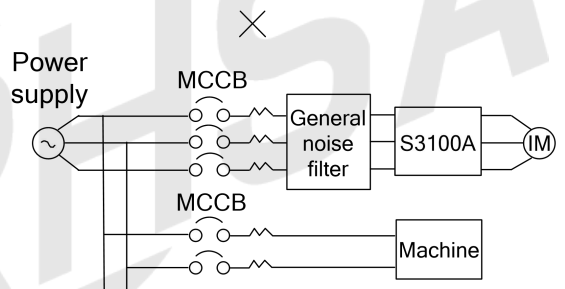
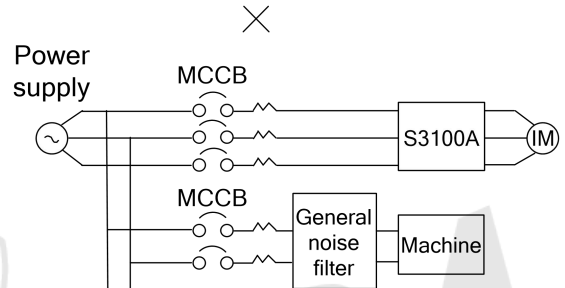

- Interference during transmission can be prohibited by adding an inverter-specialized noise filter at main circuit output side. For preventing electromagnetic radiation, a metal tube shall be installed, and distance from signal wiring of other control machines shall be 30cm at least.

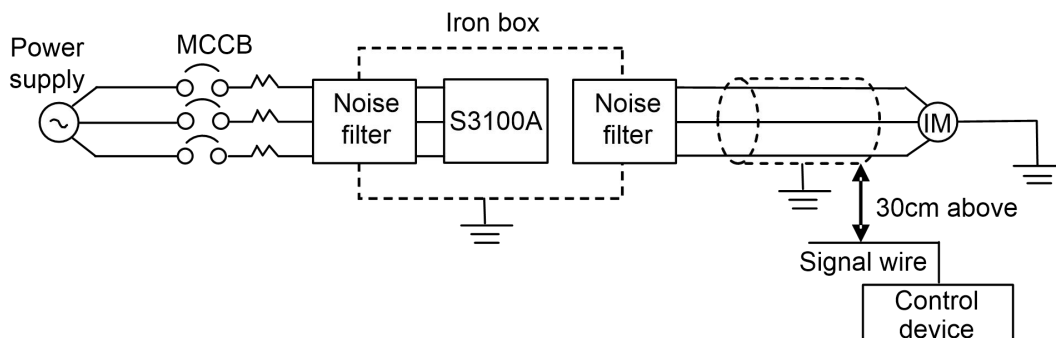

●Voltage drop of wiring shall be considered providing that inverter and motor are with an excessive distance.

Voltage drop (V) = $\sqrt{3}$ × wiring resistance (Ω/km) × wire length (m) × current × 10⁻³, load wave frequency shall be modified according to wiring prepared.

Distance between inverter and motor wiring	Below 50m	Below 100m	Above 100m
Allowable carrier frequency	Below 12kHz	Below 9kHz	Below 6kHz
Set value for parameter 00-10	12	9	6

(B)Wiring for control circuit shall be isolated or far from main circuit wiring or other high voltage/current power lines, thus electromagnetic interference shall be avoided.

●For preventing electromagnetic interference and false sequence, shielding wiring shall be used for control circuit. Shielding wiring shall connect grounding terminals.

Distance for wiring shall be 50m or less.

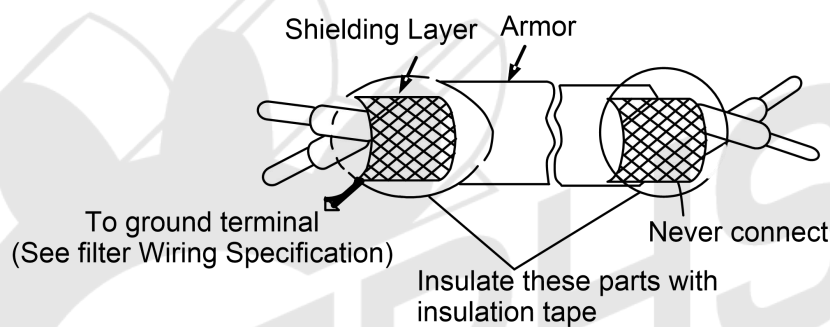

(C) Grounding terminal for inverters shall be grounded properly. 220V: ground resistance below 100Ω, 440V: ground resistance below 10Ω.

- AWG shall be taken as electrical equipment technical standard for ground wire. Ground wire shall be as short as possible.
- Never ground simultaneously for Inverter ground wire with other large current load (such as welding machine or large Power motors). They shall be grounded separately.
- Ground circuit shall be avoided when several inverters are grounded simultaneously.

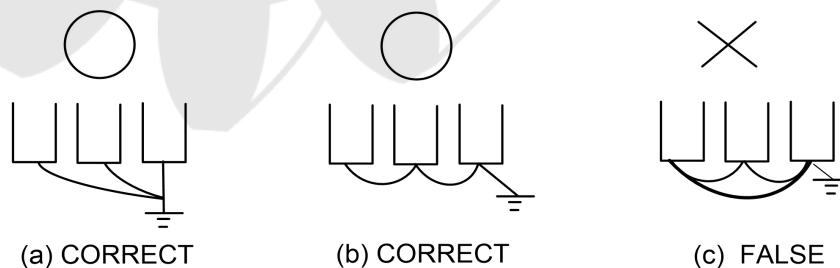

(D)Cable line width for main circuit and control circuit shall be selected according to power line standard.

(E) After completing of grounding and wiring, check for the following items:wiring is proper; wire is not broken and screws are securely locked.

2.4 Basic Wiring Diagram

Wiring of AC motor drive can be divided into two parts, the main circuit and control circuit. After removing the cover, terminals of main circuit and control circuit shall be found. Users must connect terminals as diagram shows.

The following diagram is the standard wiring diagram of S3100A series AC motor driver. If only digital control panel was used, only main circuit terminal wiring applicable.

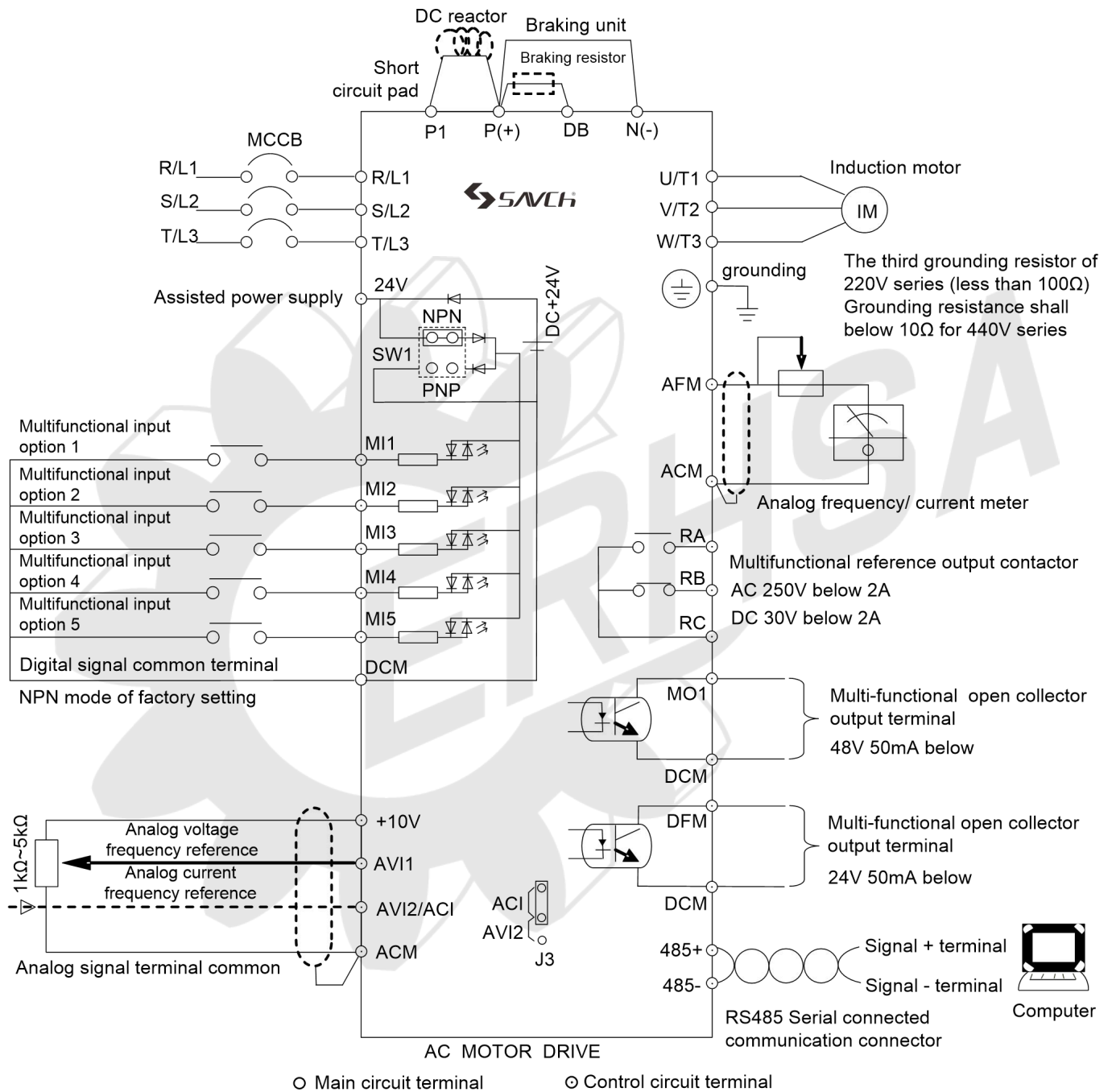

Remarks:

1. The external terminal has two AVI inputs (AVI1, AVI2), one of which is shared with ACI and can be switched to each other.
2. Analog current frequency command ACI: It can switch 4~20mA or 0~+10V as input signal according to J3.
3. There are 5 multi-function input terminals (MI1~MI5) in the external terminal, and the configuration input can be selected.
4. The external terminals have 2 open collector outputs (MO1, DFM).
5. The external terminal has one relay output (RA-RB-RC).
6. The power of 22kW and above can be equipped with I/O expansion card: HCA-EIO-AO/MC1, the whole machine realizes 2 analog (voltage/current optional) signals + 2 relay outputs.
7. The DC reactor, braking unit and braking resistor are selected according to the requirements. When using the DC reactor, please remove the short-circuit copper sheet between P1 / P (+) before connecting.

Main Circuit Terminal Descriptions

Description for S3100A Series inverter terminals

Terminal symbols	Function
R/L1,S/L2,T/L3	Main circuit AC power supply input (For single phase input, connect R/L1 andT/L3)
U/T1,V/T2,W/T3	Connect to motor
P(+),DB	Braking resistor connecting terminal
P(+),N(-)	Brake unit connection terminal
P1,P(+)	External DC reactor
	For grounding (High voltage wave impact and noise interference shall be avoided.)

Terminal Symbol Description

Terminal symbols	Function of Terminal	Specification
RA-RC	Multifunctional reference signal output contactor	See description 06-01 for relay contactor output
RB-RC	Multifunctional reference signal output contactor	
MI1-DCM	Multifunctional input option 1	See description from 04-00 to 04-04
MI2-DCM	Multifunctional input option 2	
MI3-DCM	Multifunctional input option 3	
MI4-DCM	Multifunctional input option 4	
MI5-DCM	Multifunctional input option 5	
MO1-DCM	Multifunctional output terminal 1	See description 06-07 (Open collector output)
DFM-DCM	Multifunctional output terminal 2	See description of 06-04(DFM(M) multifunction output) or of 06-06(DFM(P) pulse output)
+10V-ACM	Power supply for speed setting	Speed reference power supply (+10V)
AVI1-ACM	Analog voltage frequency reference	0 to +10V/Max. output frequency
AVI2-ACM	Analog voltage frequency reference	0 to +10V/Max. output frequency
ACI-ACM	Analog current frequency reference	4 to +20mA/Max. output frequency
AFM-ACM	Analog frequency/ current meter	0 to +10V/Max. output frequency
485+-485-	Serial connected communication board	RS485 Serial connected communication connector
24V-DCM	Assisted control power supply	DC 20V-24V (50mA Max)

Note:Please insulate the control signal wire with insulation tape.

Only use double Null Modem from communication cable of RS485.

2.5 External Dimensions

2.5.1 Inverter Size

Model	W	W1	W2	H	H1	D	M	N	Fig.
S3100A-2T0.4G	108	94	94	138.1	118	159.5	5	5	Size 1
S3100A-2T0.75G									
S3100A-2T1.5G									
S3100A-4T0.75G/1.5P									
S3100A-4T1.5G/2.2P									
S3100A-4T2.2G/4.0P									
S3100A-2T2.2G	130	108	108	209	198	169.8	5	5	Size 2
S3100A-2T4.0G									
S3100A-4T4.0G/5.5P									
S3100A-4T5.5G/7.5P									
S3100A-4T7.5G	140	122	122	260	248	176.6	6	6	Size 3A
S3100A-4T7.5G/11P									
S3100A-4T11G/15P									
S3100A-4T15G	180	160	160	298	284	180	6.5	6.5	Size 3
S3100A-2T5.5G									
S3100A-2T7.5G									
S3100A-4T7.5G/11P									
S3100A-4T11G/15P									
S3100A-4T15G/18.5P									
S3100A-4T18.5G/22P									
S3100A-4T22G	260	176	176	412	397.5	203	6.5	13	Size 4
S3100A-2T11G									
S3100A-2T15G									
S3100A-2T18.5G									
S3100A-4T22G/30P									
S3100A-4T30G/37P									
S3100A-4T37G/45P	305	160	-	460	442	243	7	14	Size 5A
S3100A-2T22G									
S3100A-4T45G/55P	320	160	230	580	563	280	9	17	Size 5
S3100A-2T30G									
S3100A-2T37G									
S3100A-2T45G									
S3100A-2T55G									
S3100A-4T55G/75P									
S3100A-4T75G/90P									
S3100A-4T90G/110P									
S3100A-4T110G	380	160	-	724.2	694	330.5	12	22	Size 6A
S3100A-4T110G/132P									
S3100A-4T132G/160P									
S3100A-4T160G									

Model	W	W1	W2	H	H1	D	M	N	Fig.
S3100A-4T110G/132P	460	160	160	778	745	340	12.5	12.5	Size 6
S3100A-4T132G/160P									
S3100A-4T160G									
S3100A-4T185G/200P	450	160	160	780	746	385	12	25	Size 7A
S3100A-4T200G/220P									
S3100A-4T185G/200P									
S3100A-4T200G/220P	393	150	150	882	849	413	13	25	Size 7
S3100A-4T220G									
S3100A-4T220G/250P									
S3100A-4T250G/280P	500	190	190	882	849	414	13	25	Size 8
S3100A-4T280G/315P									
S3100A-4T315G									
S3100A-4T315G/355P									
S3100A-4T355G/400P	626	250	250	982	949	408	13	25	Size 9
S3100A-4T400G/450P									
S3100A-4T450G/500P									
S3100A-4T500G	737	250	250	982	947	413	13	25	Size 10
S3100A-4T560G Integrated machine									
S3100A-4T630G Integrated machine									

2.5.2 External Dimensions of Inverter

Size 1

Unit:mm

S3100A-2T0.4G~2T1.5G

S3100A-4T0.75G/1.5P~4T2.2G/4.0P

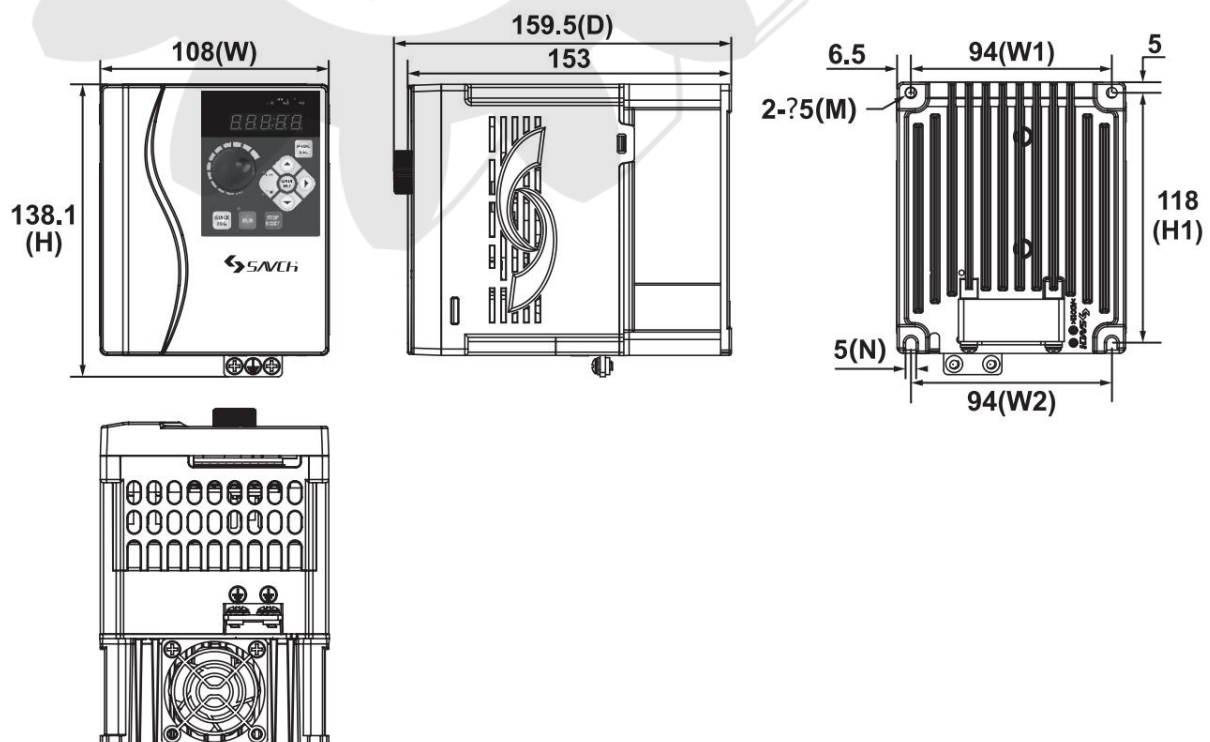

Size 2

Unit:mm

S3100A-2T2.2G~2T4.0G

S3100A-4T4.0G/5.5P~4T7.5G

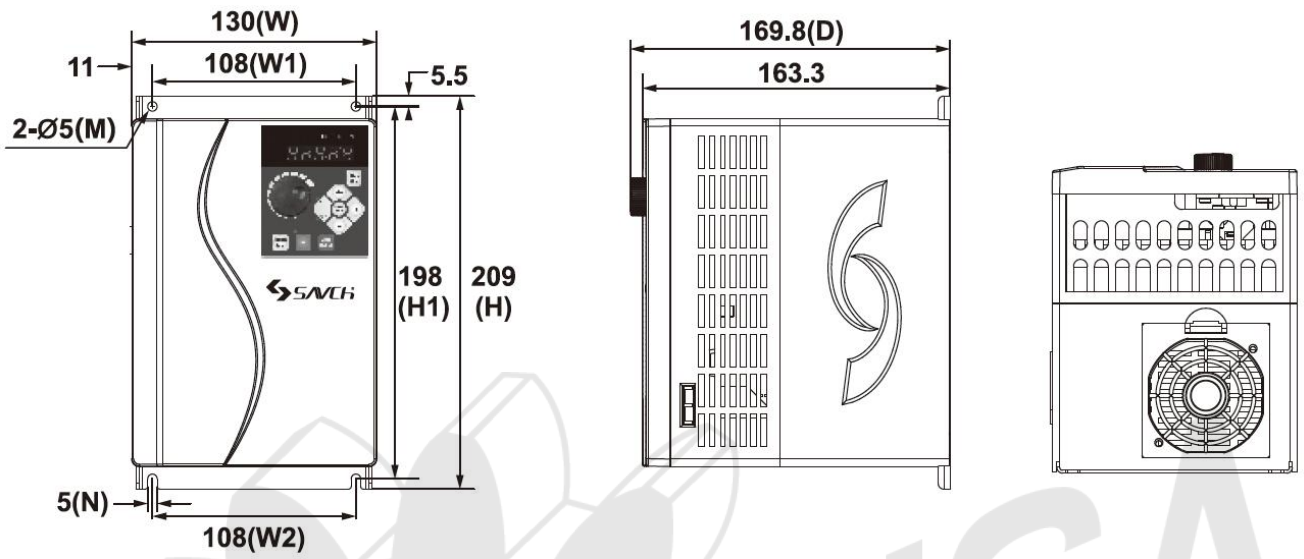

Size 3A

Unit:mm

S3100A-4T7.5G/11P~4T15G

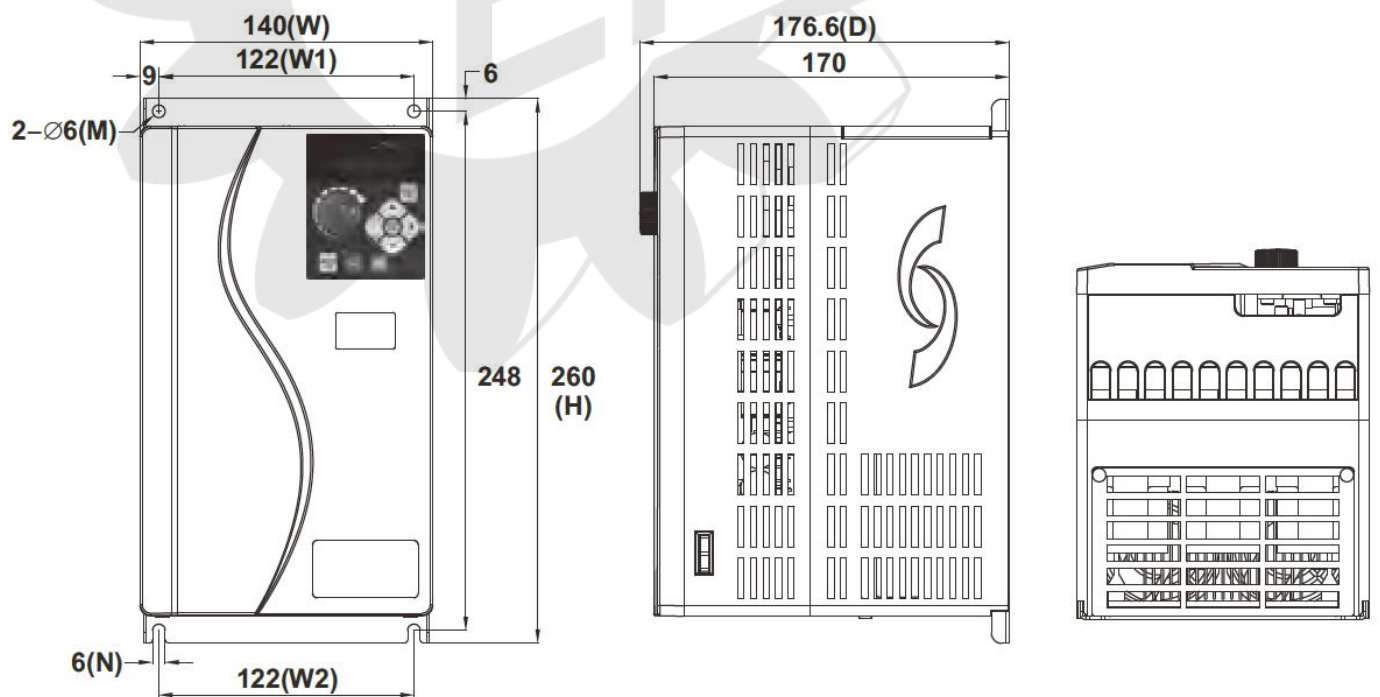

Size 3

Unit:mm

S3100A-2T5.5G~2T7.5G

S3100A-4T7.5G/11P~4T22G

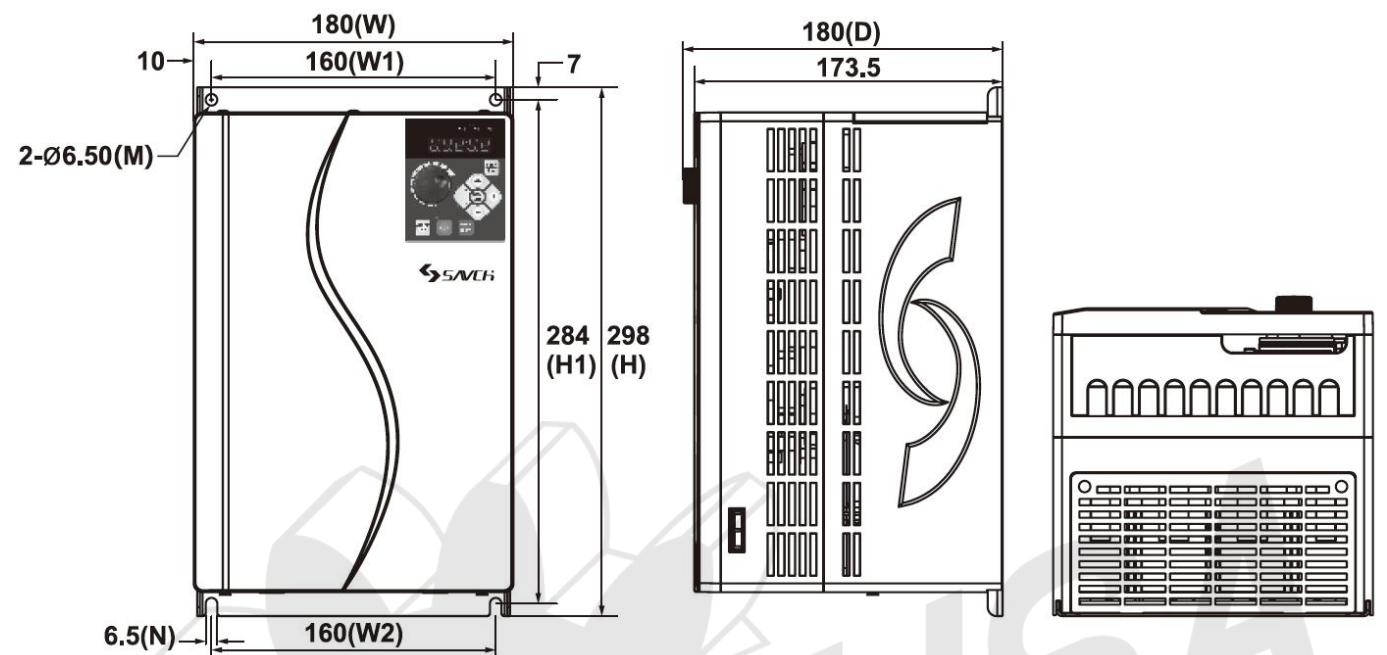

Size 4

Unit:mm

S3100A-2T11G~2T18.5G

S3100A-4T22G/30P~4T37G/45P

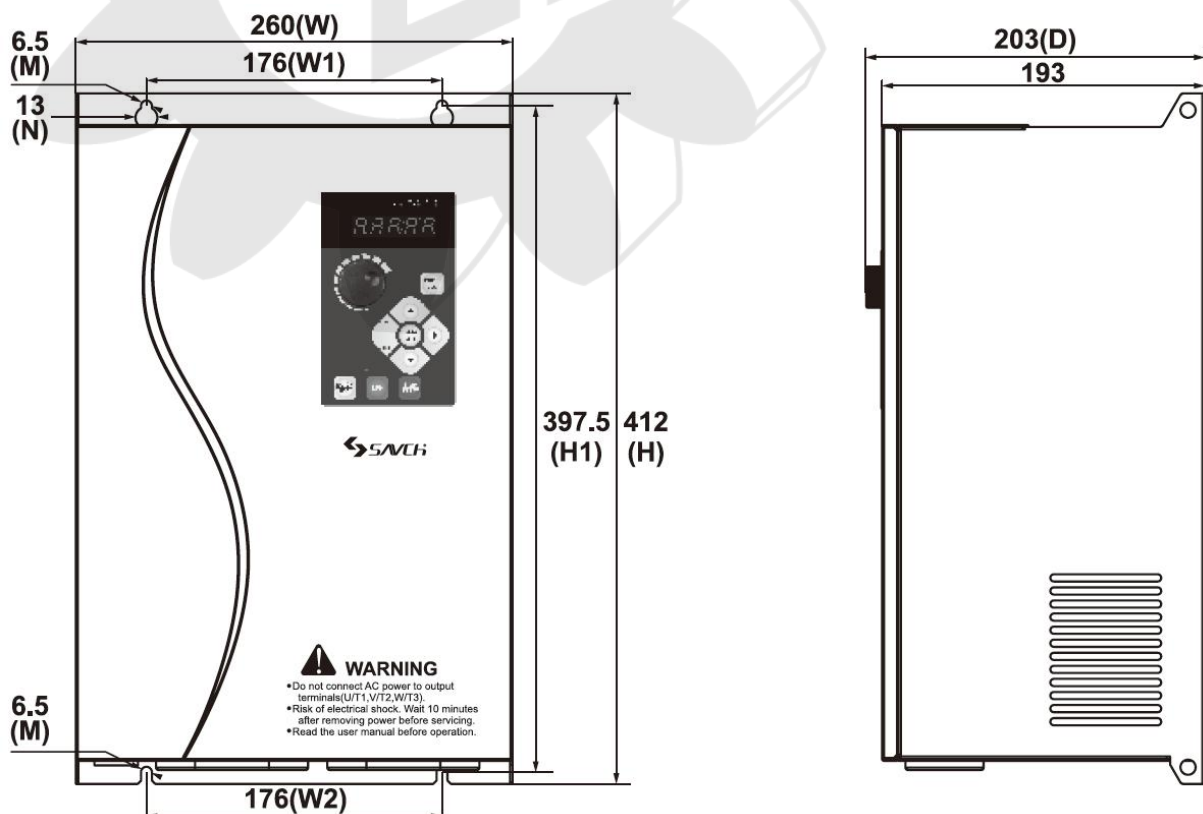

Size 5A

Unit:mm

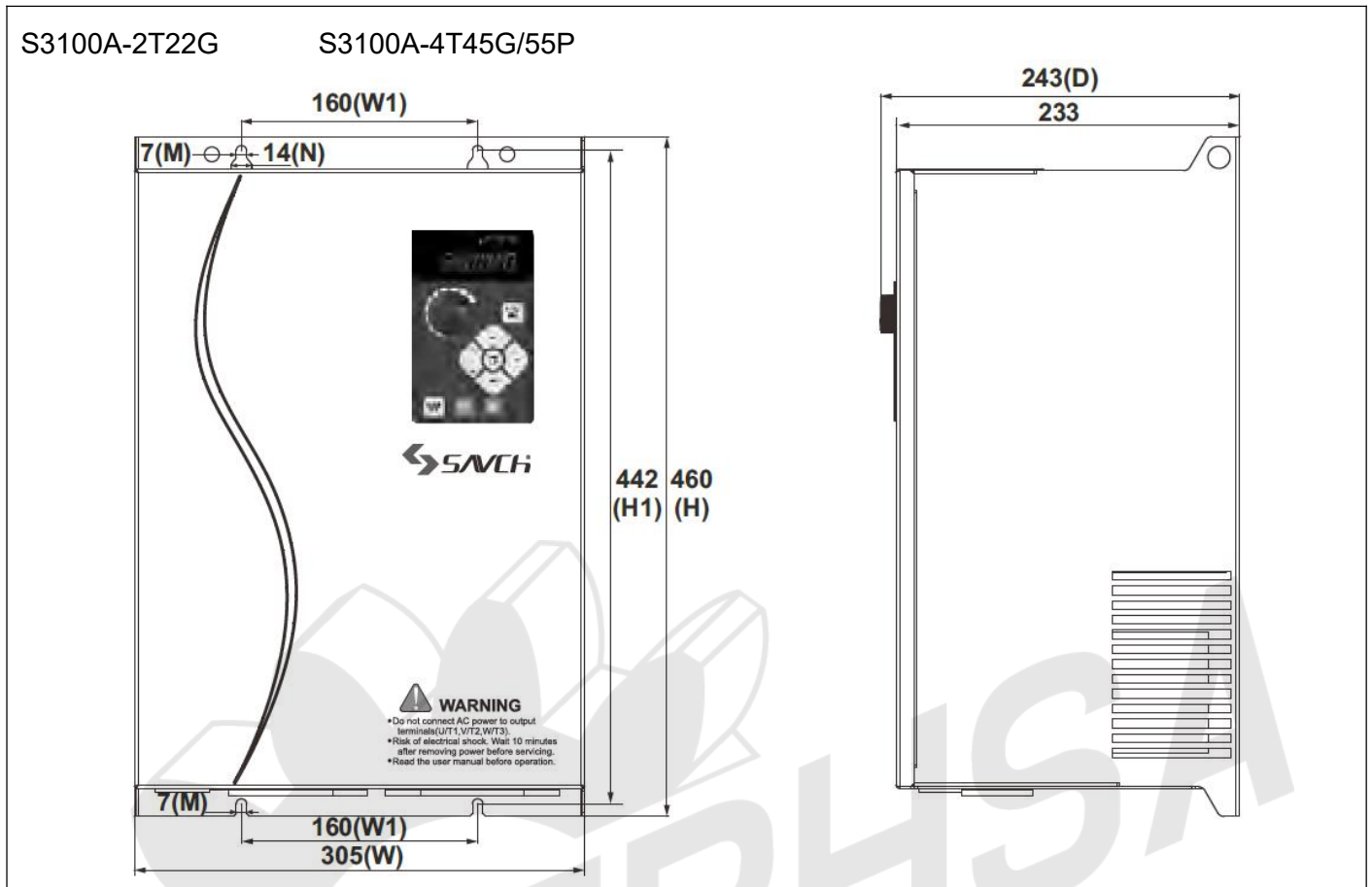

Size 5

Unit:mm

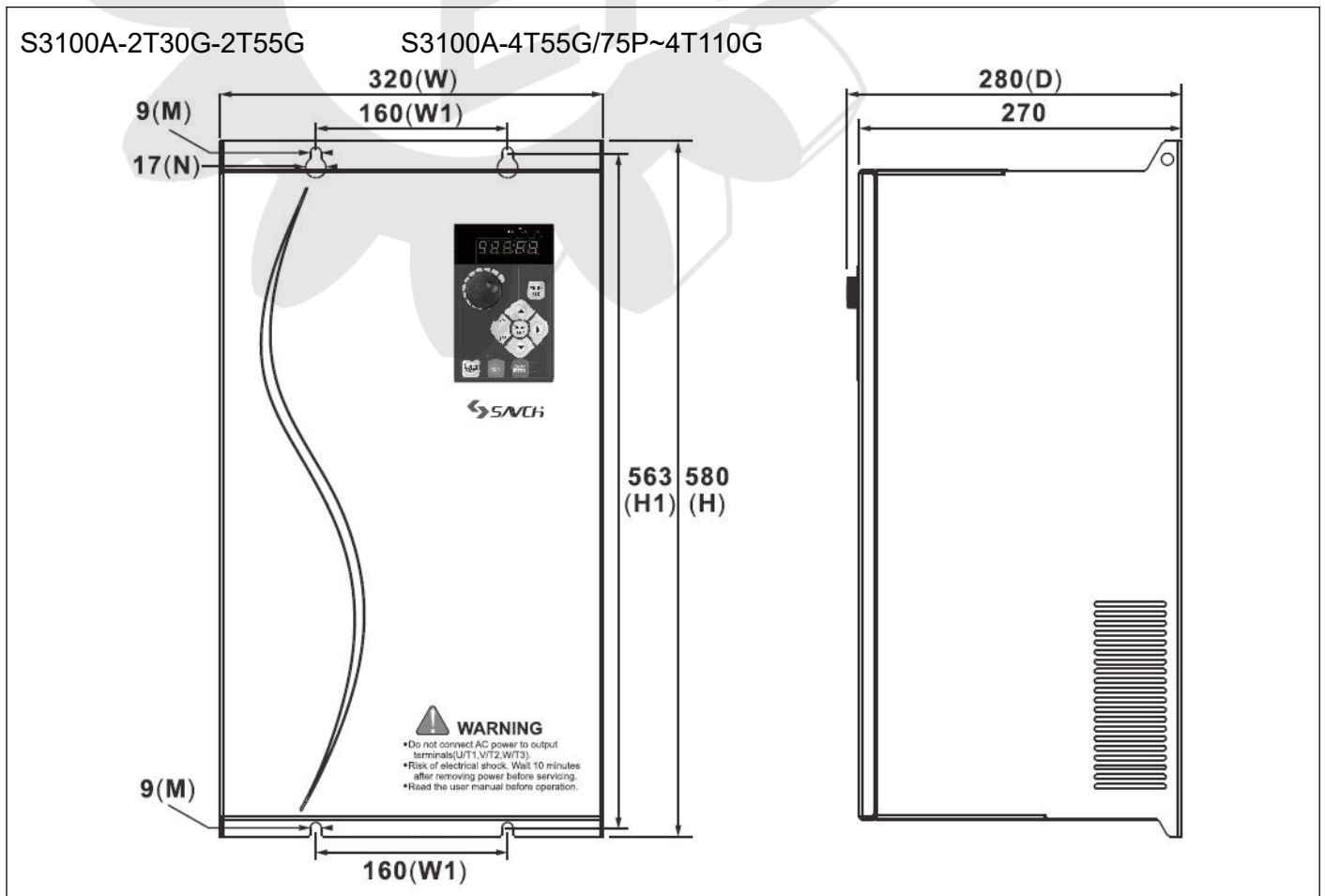

Size 6A

Unit:mm

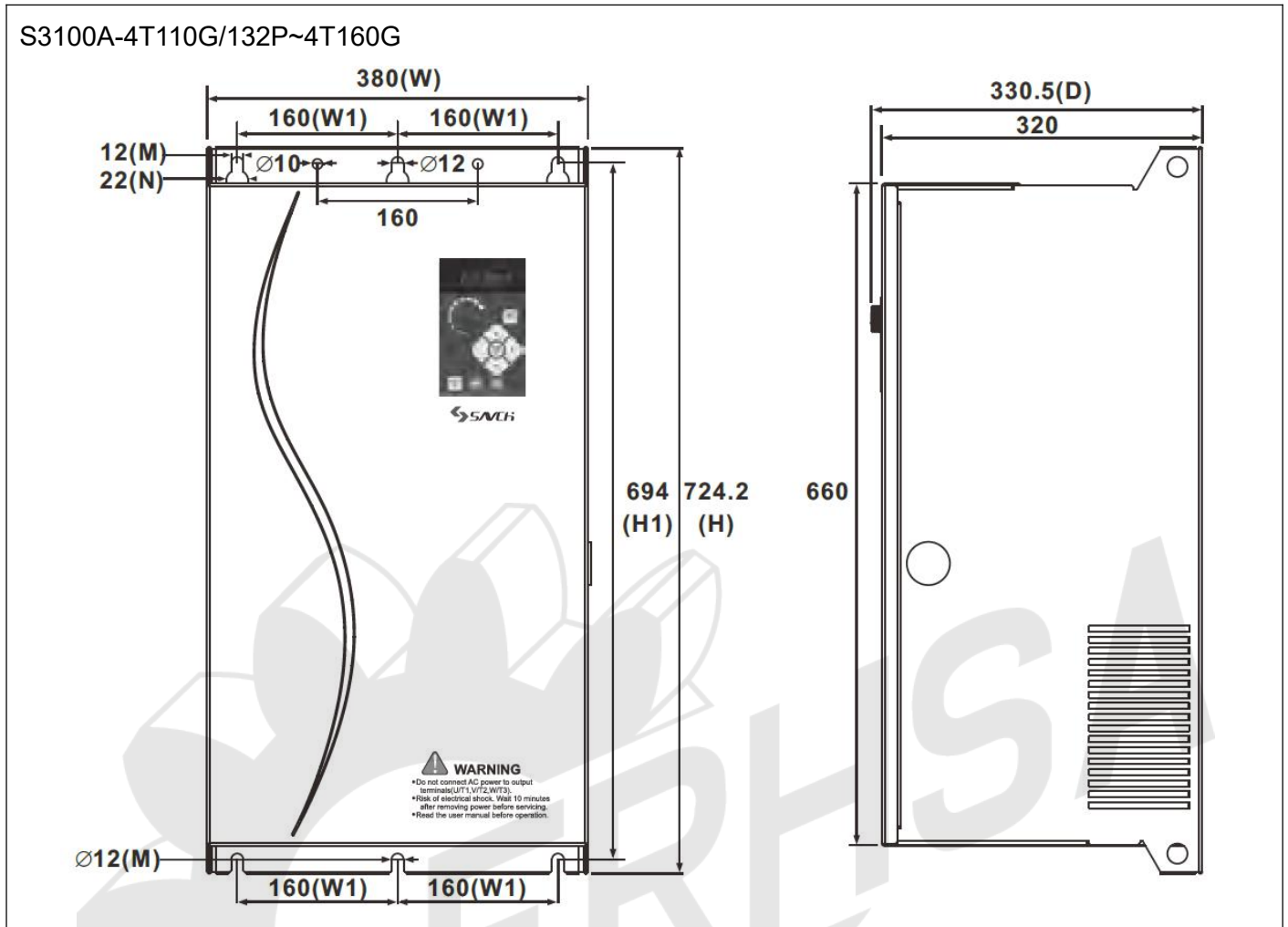

Size 6

Unit:mm

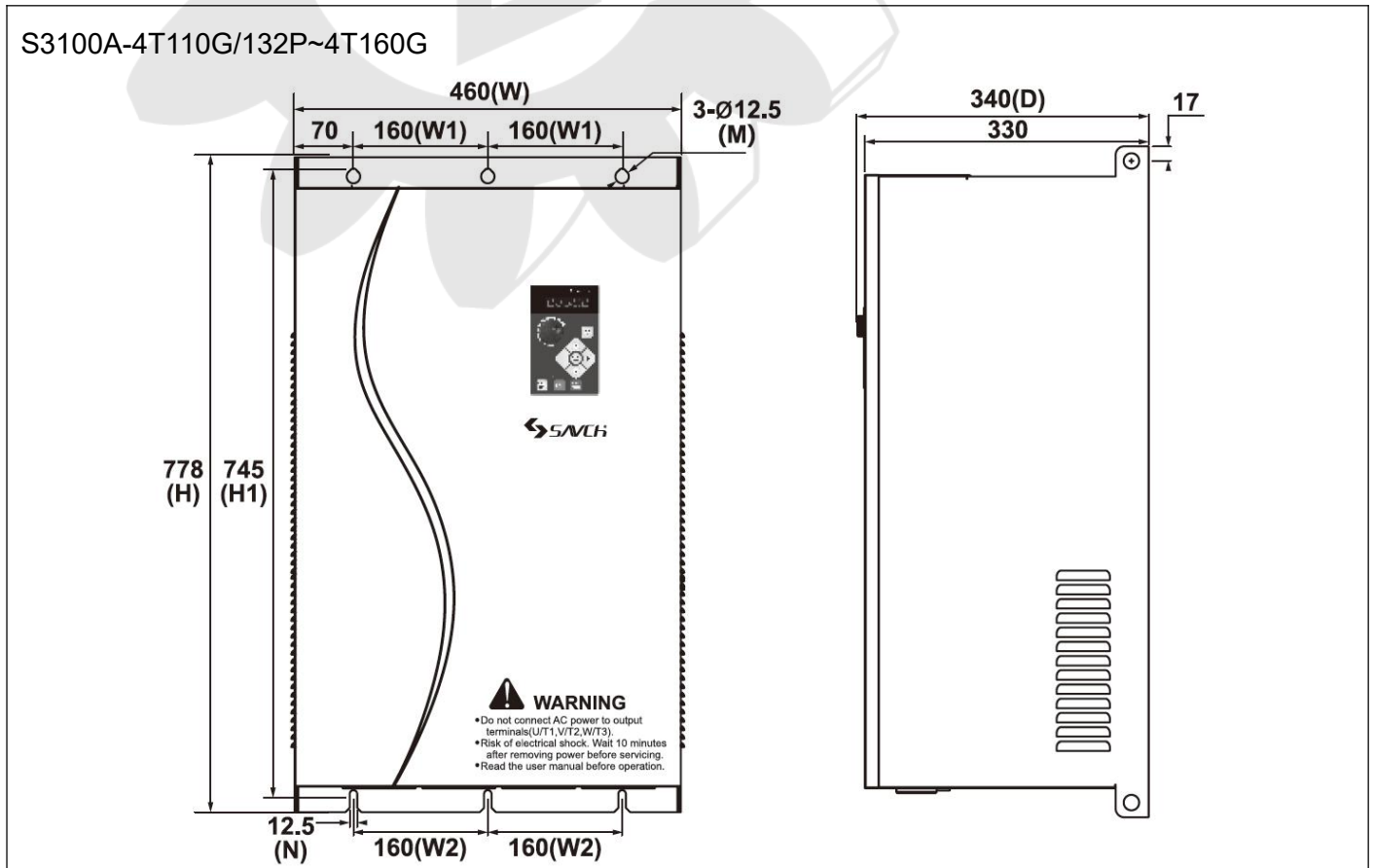

Size 7A

Unit:mm

S3100A-4T185G/200P~4T200G/220P

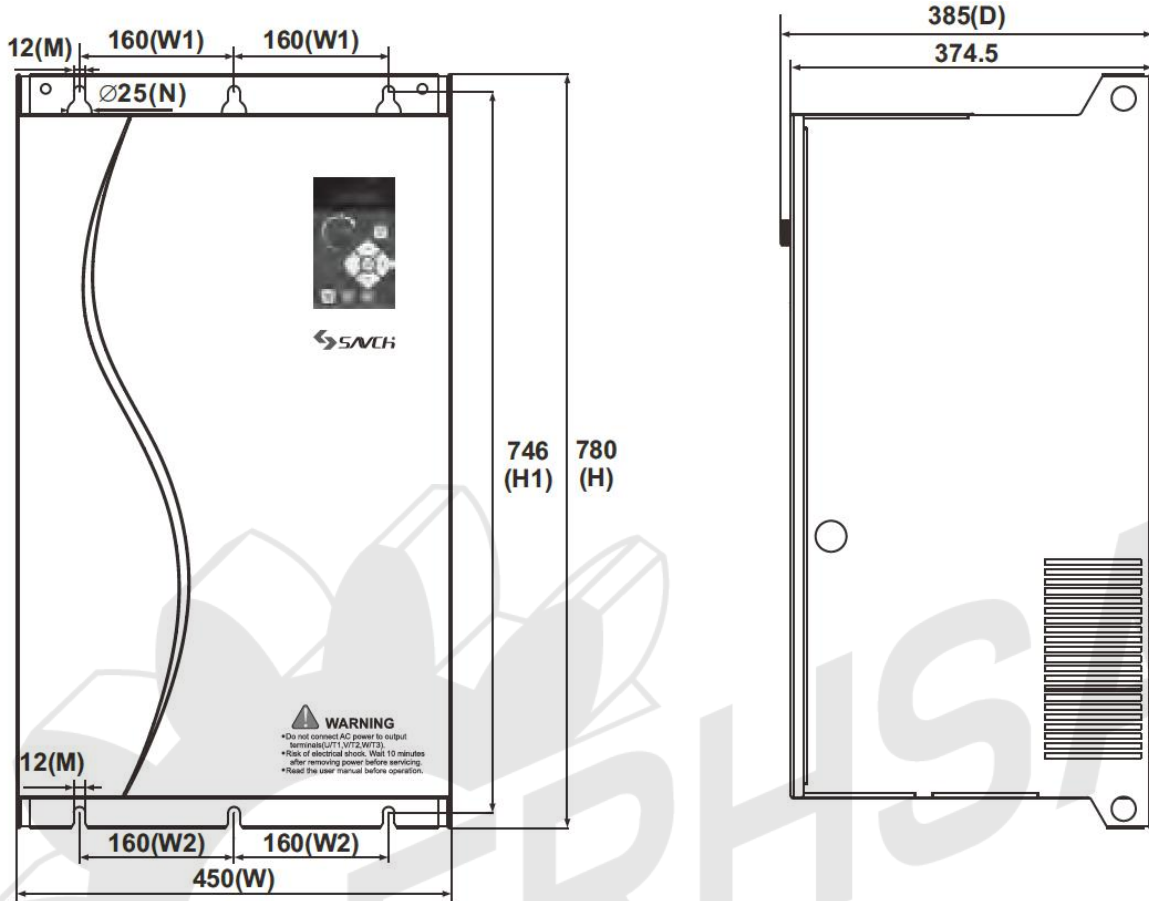

Size 7

Unit:mm

S3100A-4T185G/200P~4T220G

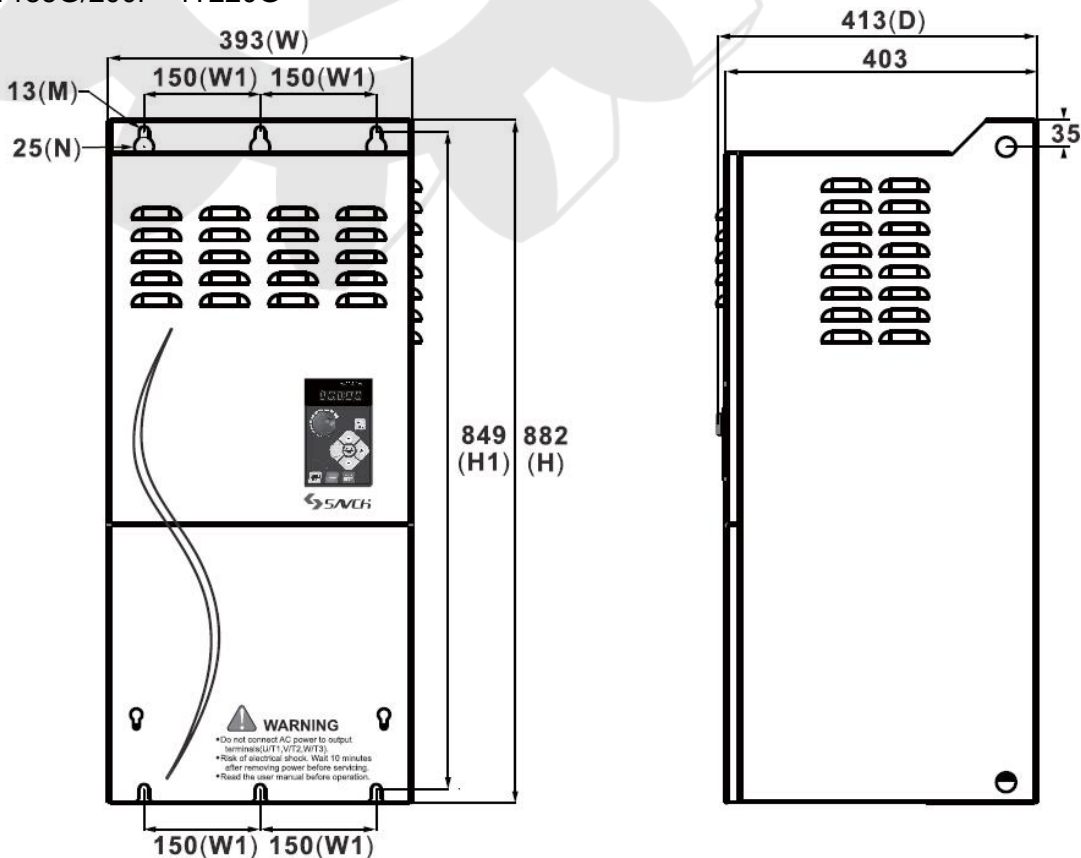

Size 8

Unit:mm

S3100A-4T220G/250P~4T315G

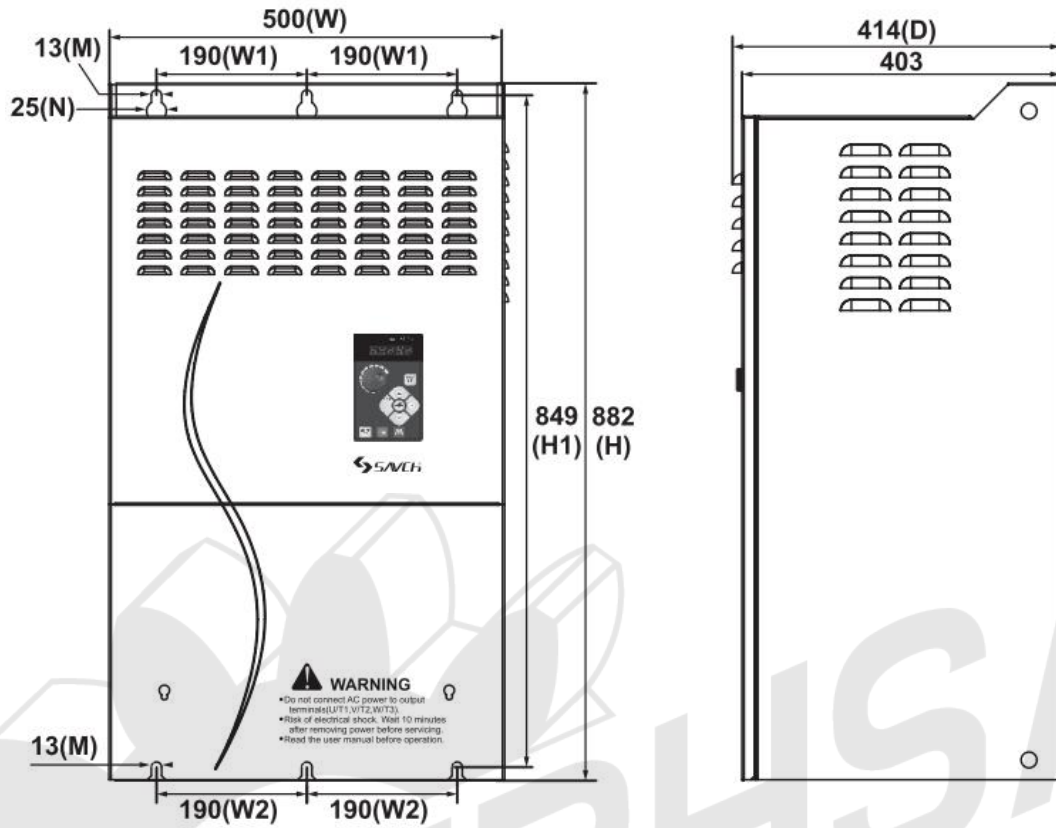

Size 9

Unit:mm

S3100A-4T315G/355P~4T400G/450P

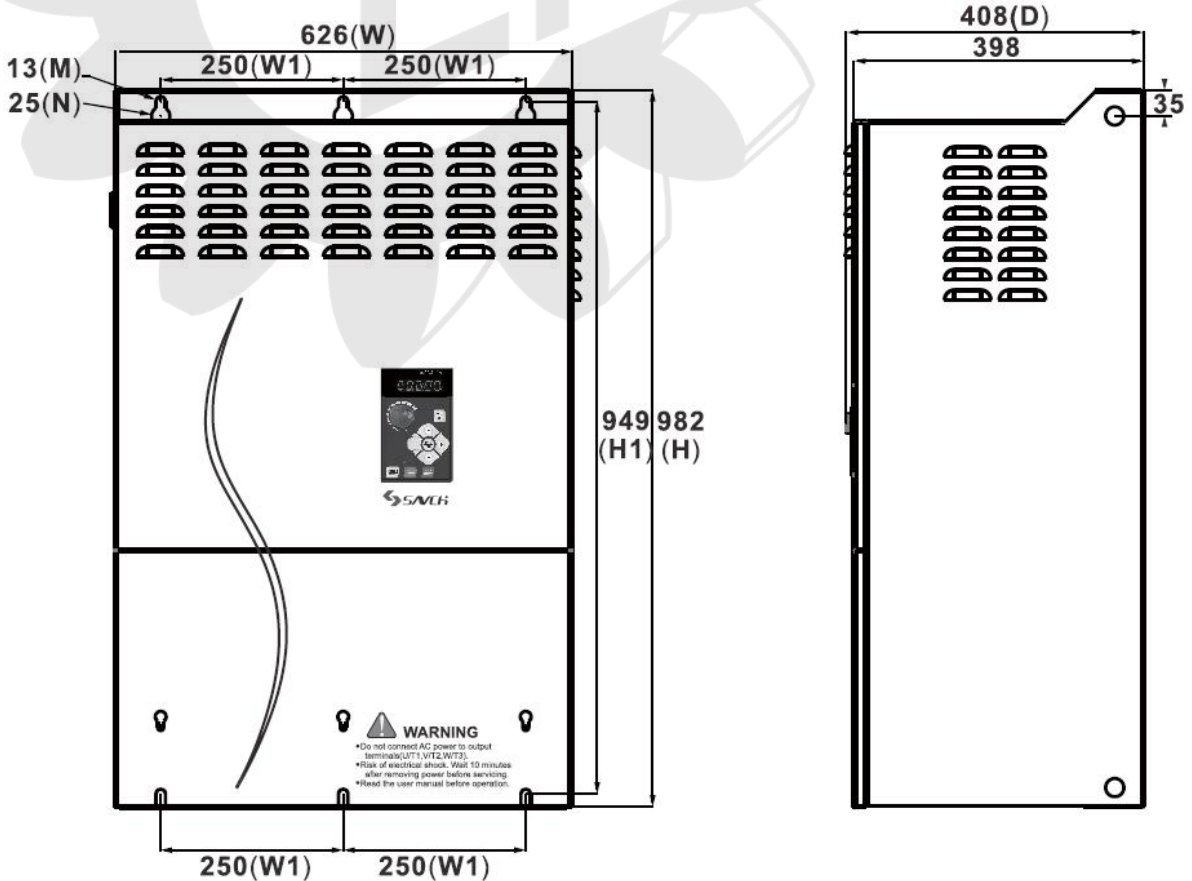

Size 10

Unit:mm

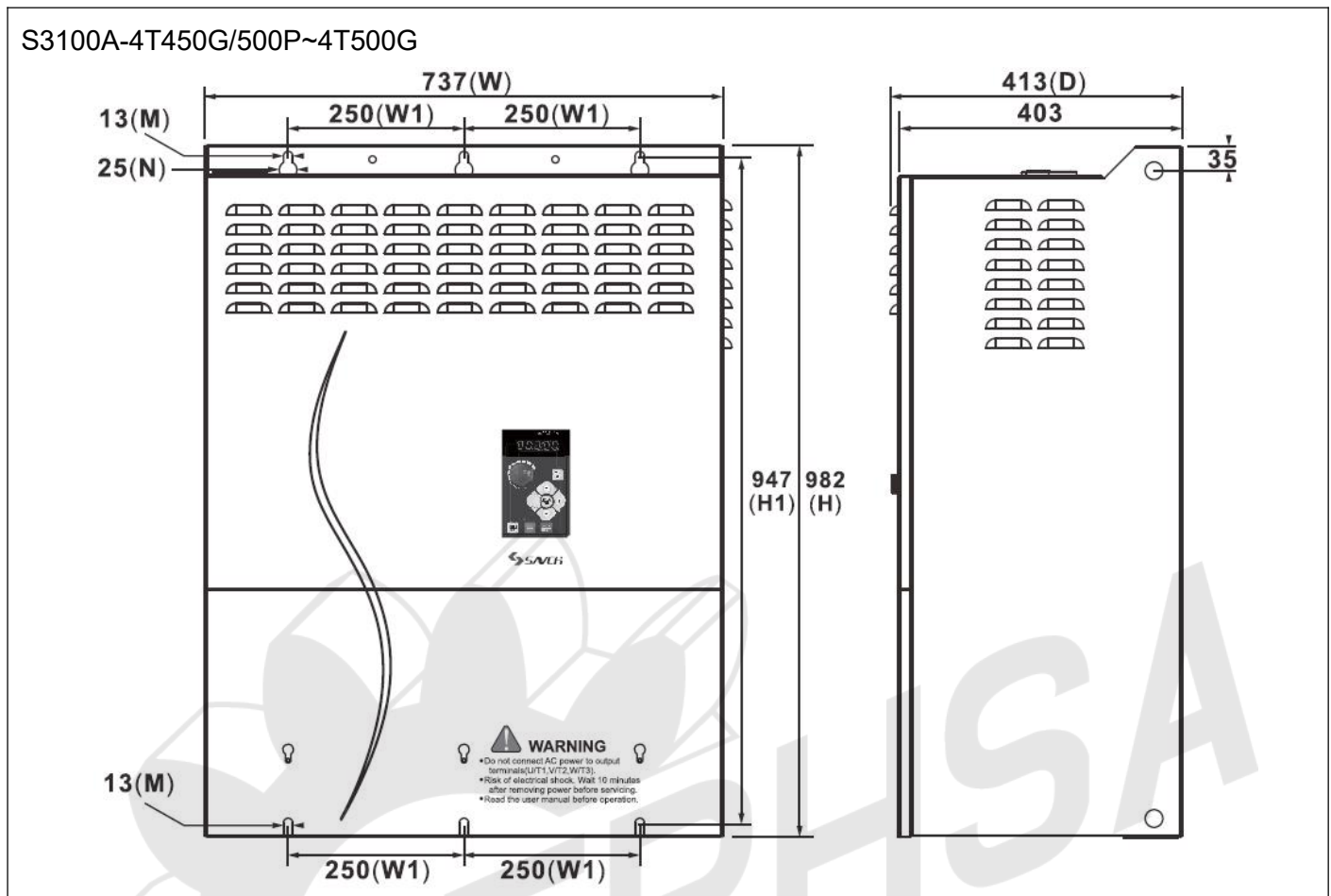

Size 11

Unit:mm

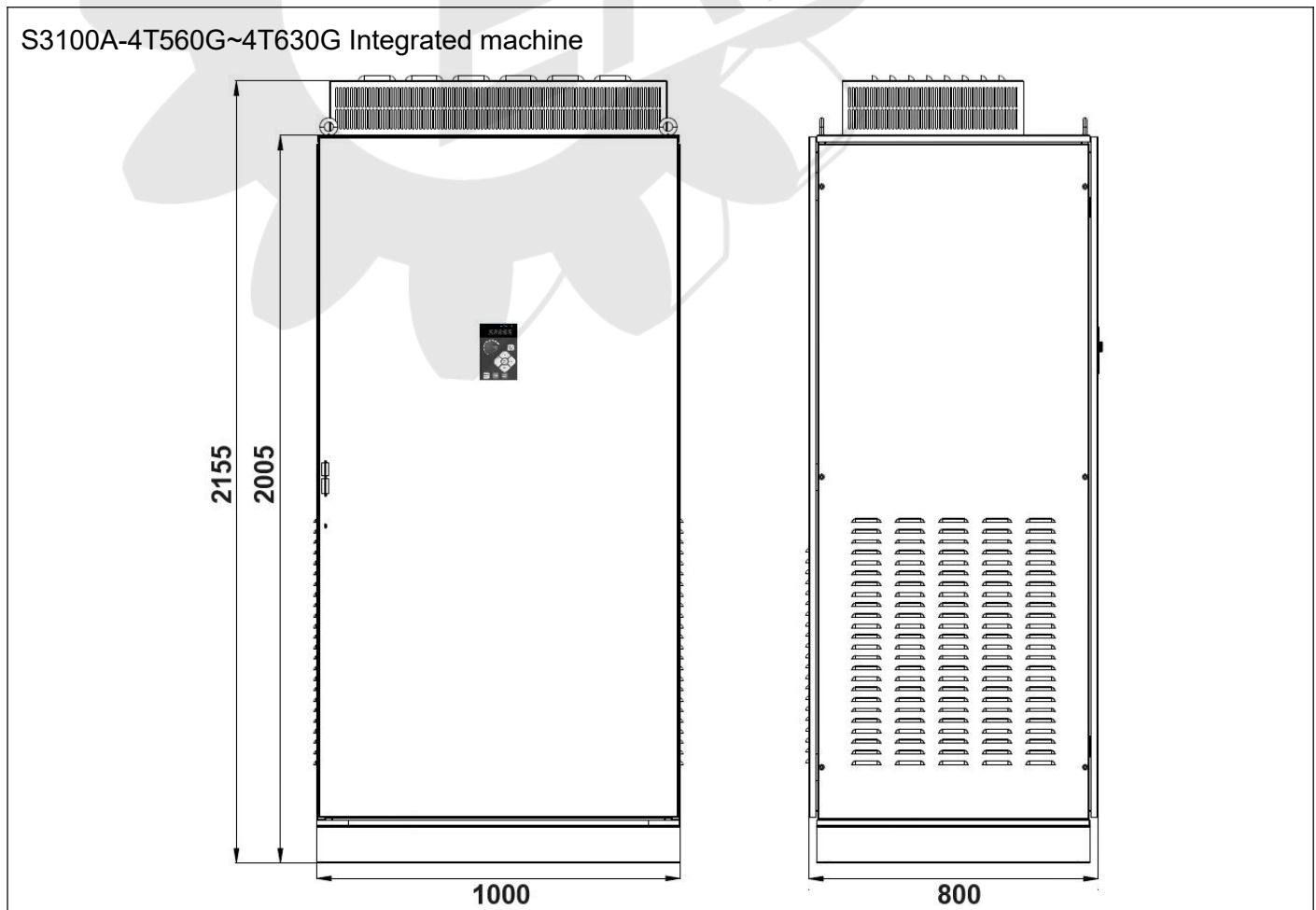

2.5.3 Multi-Functions Operation Keypad

- Small power keypad (HCA-OP-A2) external dimensions and Installation dimensions

Below 18.5kW (include 18.5kW)

Unit:mm

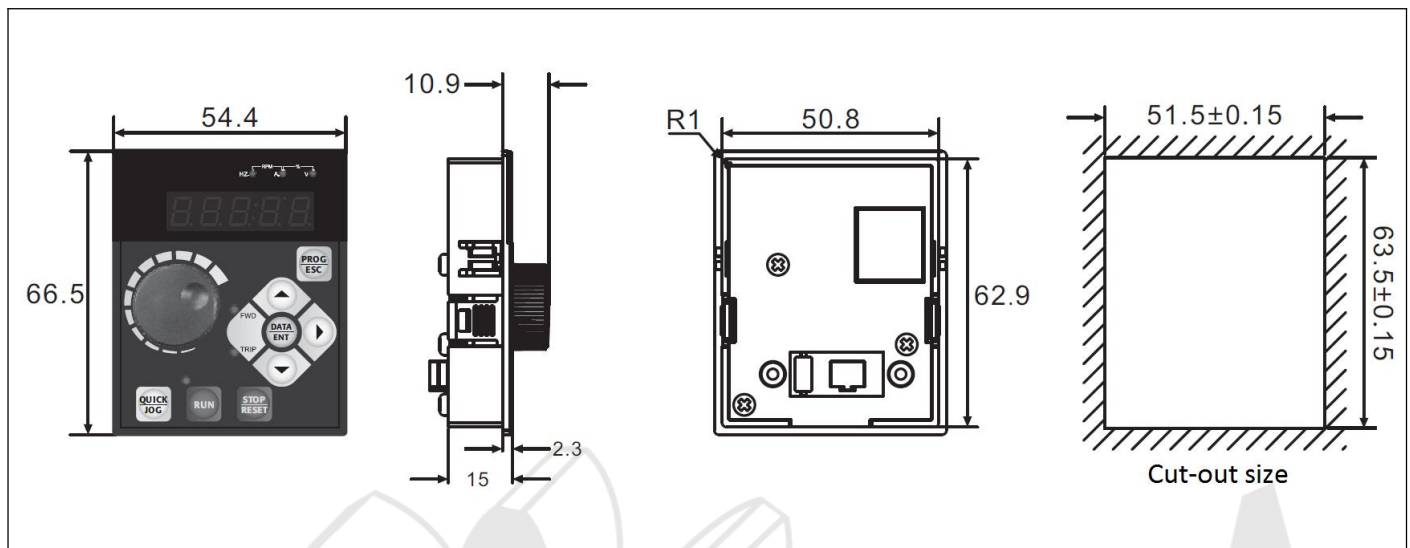

- Large power keypad (HCA-OP-B2) external dimensions and Installation dimensions

Above 22kW (include 22kW)

Unit:mm

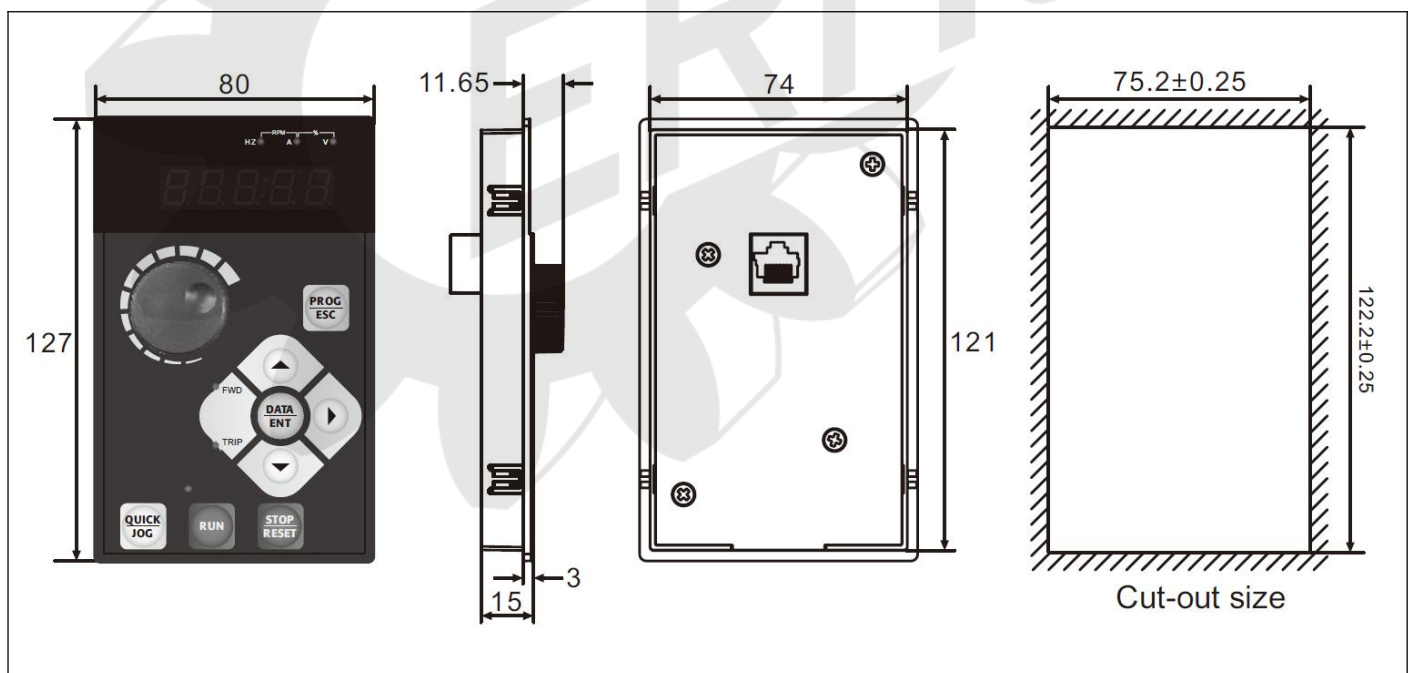

Note: This keyboard can be extended with ordinary network cable (8 cores).

Dimensions of epitaxial supporting box of extending keypad

- Below 18.5kW (include 18.5kW)

Unit:mm

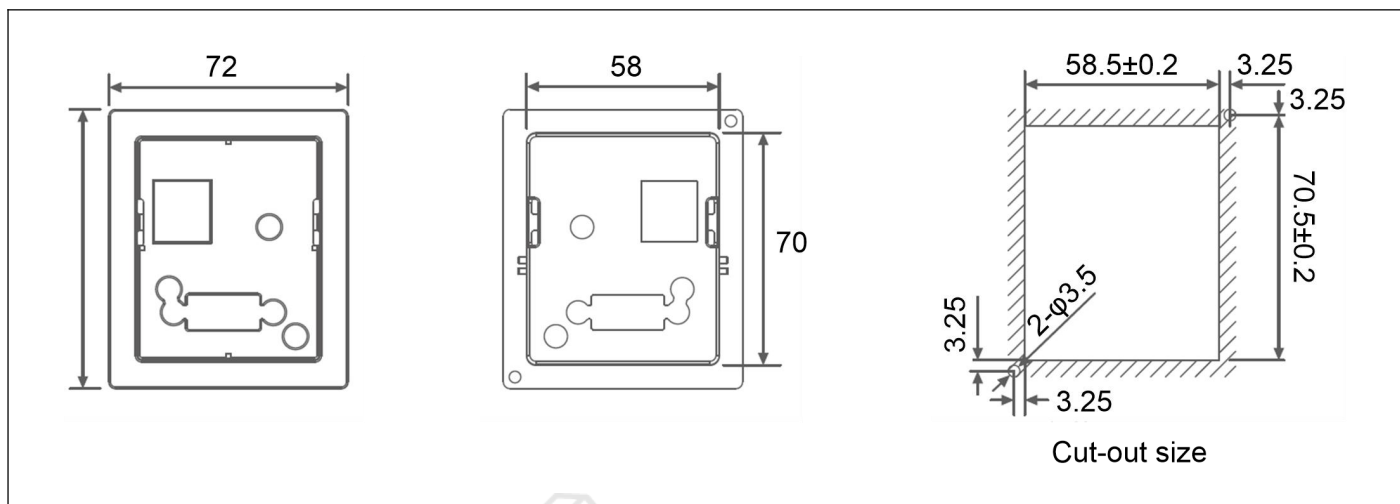

- Above 22kW (include 22kW)

Unit:mm

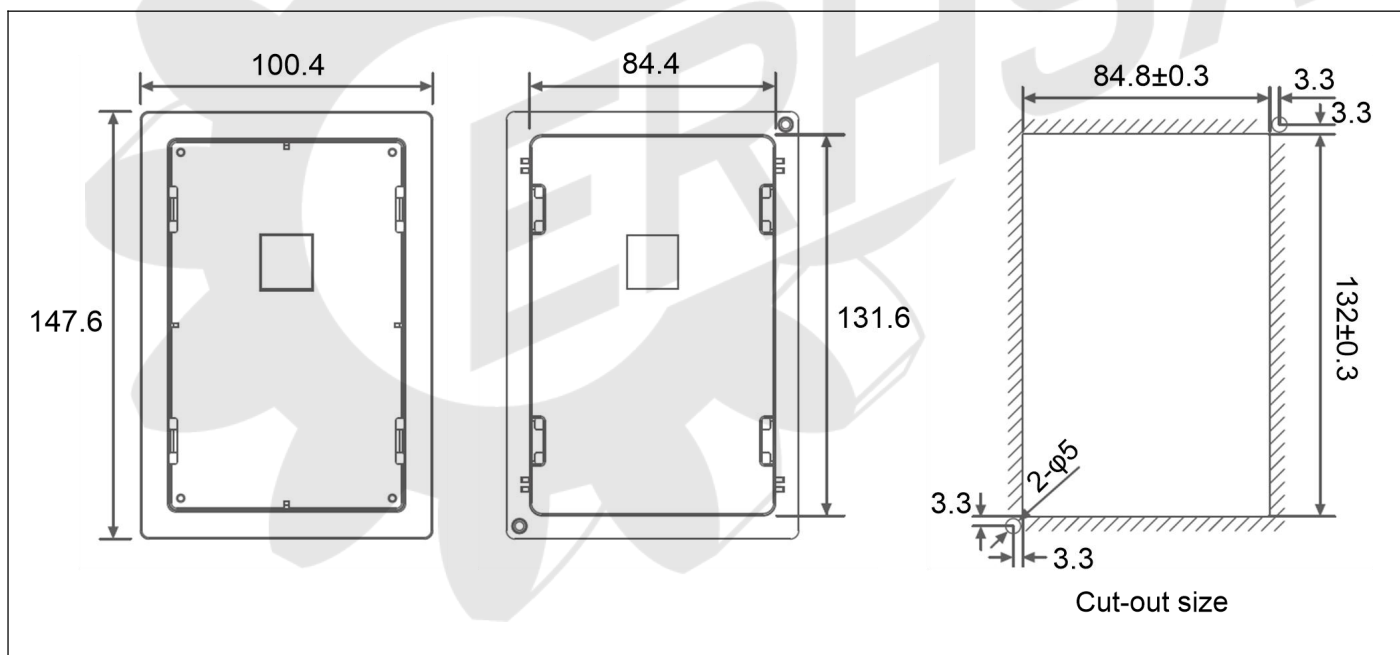

3 KEYPAD DESCRIPTION





3.1 Keyboard Description for HCA-OP-A2 / HCA-OP-B2 Digital Operator

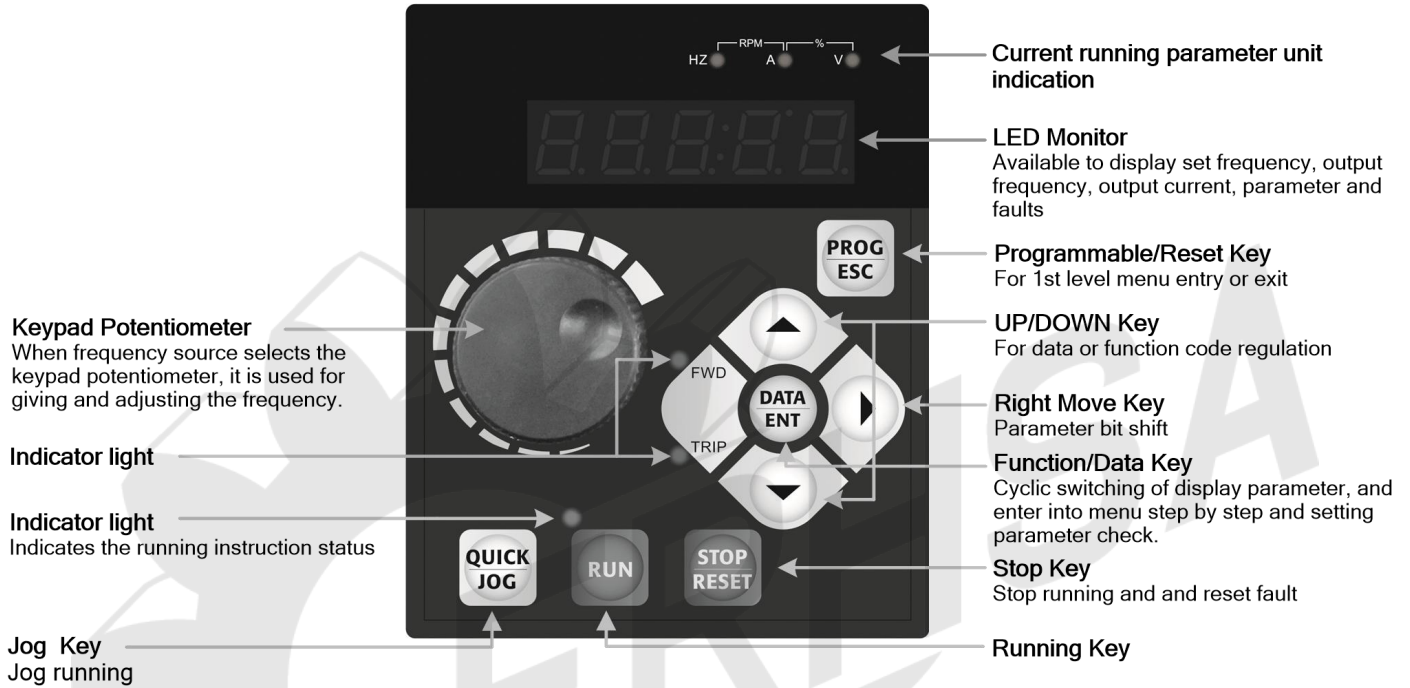

Descriptions and functions of the keyboard

Locating on AC motor drive, the digital operator HCA-OP-A2/HCA-OP-B2 has two spaces: display space and operating space. Programmed mode and different operation states shall be displayed on the display space, while for the operating space, it is an interface for communication of the operators and AC motor drive.



Functions description of the keyboard

Display and Keyboard		Functions description
	Program key	Enter or quit the first menu
	Enter key	Enter into menu step by step, set parameter
	UP key	Increase of data or function code
	DOWN key	Decrease of data or function code
	Shift key	On stopping and running mode, the parameter can be selected circularly. Able to select the parameter when modifying it.

Display and Keyboard		Functions description
	Running key	For start operation under operation keyboard mode
	Stop / reset key	To stop motor in running mode by pressing this key, limited by function code 08-02; To reset fault in the state of fault alarm, free from function code 08-02.
	Shortcut multifunction key	The key is identified by function code 08-01. 0:Jog-run 1:switching key for forward and reverse 2:Clear UP / DOWN setting, clear the frequency value set by UP / DOWN.

Indicator Description

1)Description of function indicator:

Name of indicator	Description of indicator
RUN/TUNE	Operation indicator ON-running OFF-stop FLICKER-parameter self-learning
FWD	Forward & Reverse run indicator: ON-reverse OFF-forward
TRIP	Fault indicator light description: The light on indicates the torque control mode, The slow flashing light indicates auto-tuning,The flashing light indicates a fault state.

2)Description of unit indicator:

Symbol	Symbol Description
Hz	Frequency
A	Current
V	Voltage
RPM	Rotating speed
%	Percentage

3.2 Description of Keyboard Operation

3.2.1 Parameter Setting

Here are three levels of menu:

- 1.Function code number group (first)
- 2.Function code labeling (second)
- 3.Function code value setting(third)

Note:Press PRG / ESC or DATA / ENT to back to second-level menu when in the third-level. The difference between them is:DATA / ENT key stores the set parameter into control board before backing to second-level menu and shifts to the next function code automatically. While PRG / ESC key backs to the second-level menu directly without storing parameters and keeps the current function code.

For example, set the frequency of function code 07-01 from 00.00Hz to 01.05Hz.

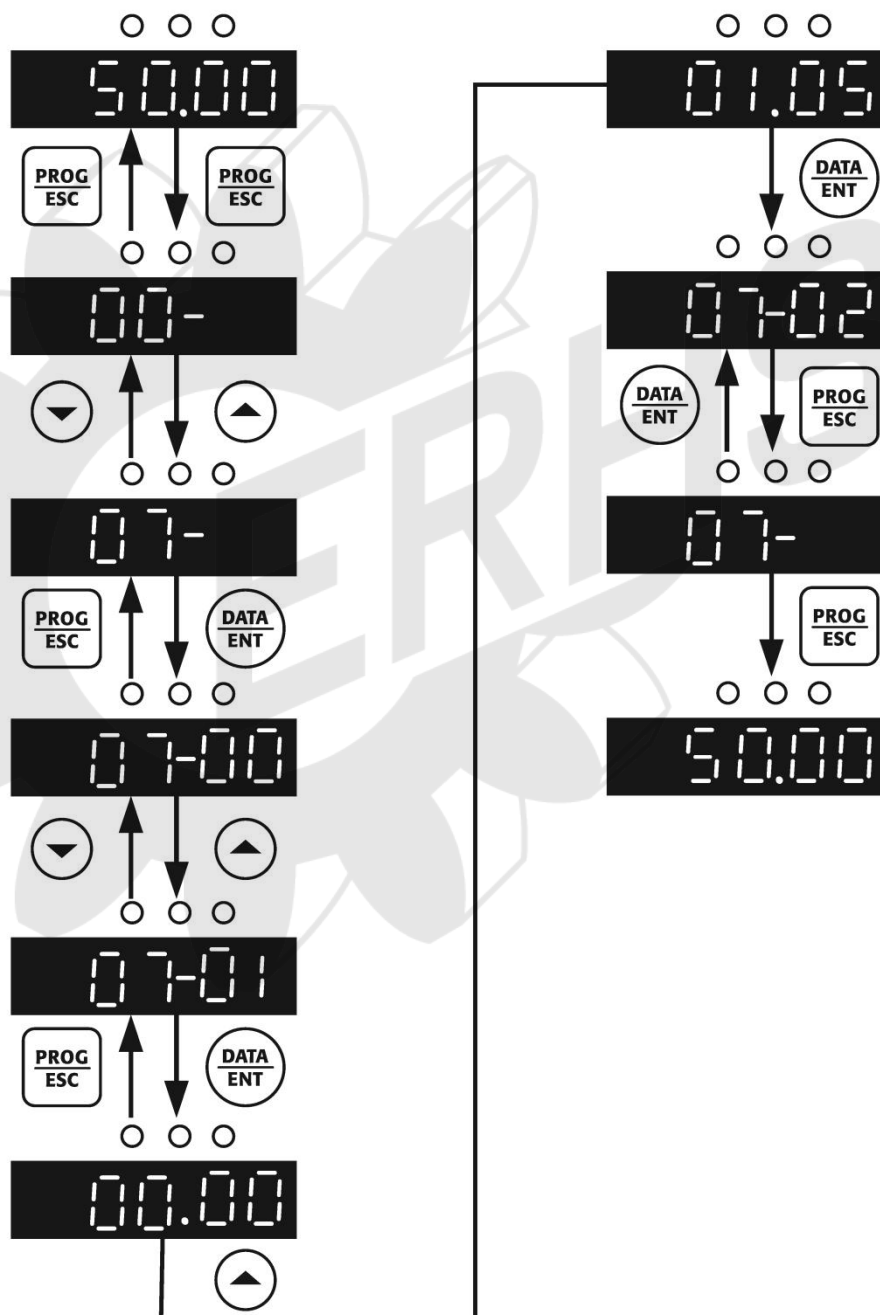

In the state of third-level menu, the function code can't be modified if the indicator does not flicker, the reason of would be:

1)The parameter s of function code can not be modified, e.g. actual detection parameters, operation record parameters, etc.

2)The parameter s of function code can not be modified in running state, the code could be modified only when the motor stops.

3.2.2 Failure Resetting

When the inverter receives a fault, it will display the relative fault information. User can reset the fault by the STOP/RESET key on keyboard or terminal function (group 04). The inverter will be in standby state after fault resetting. If the user doesn't reset when the inverter receives a fault, it will be in running protection state and unable to be operated.

3.2.3 Motor Parameter Self-learning

The nameplate parameter of motor is needed to be input accurately when selecting open loop vector control. The inverter will match the standard motor parameter according to the nameplate parameters. To obtain the excellent control performance, it is recommended to carry out the motor parameters self-learning, the operation step as follows.

First, select the running reference channel (00-00) as the keyboard reference channel .

Then input following parameters according to motor actual parameters.

01-02: motor rated power

01-03: motor rated frequency

01-04: motor rated rotation speed

01-05: motor rated voltage

01-06: motor rated current

During the self-learning process, select the 01-01 self-learning mode and press the DATA / ENT key, the keyboard will display TUNE, and then press the keyboard RUN key, the inverter will drive the motor to perform self-learning for about 2 minutes, the display information disappears, and returns Normal display status indicates that the motor parameter self-learning is completed.

Note: During the process of self-learning, the motor must to be uncoupled from load. Otherwise, incorrect parameters would be obtained.

3.2.4 Password Setting

S3100A series inverters provide user password protection function. When 08-00 is set to non-zero, it is the user password, exit the function code editing state, the password protection is effective, and press PRG / ESC key again to enter the function code editing state, "-----" is displayed. After pressing the DATA / ENT key, the "00000" user password input interface is displayed. The operator must enter the user password correctly, otherwise he cannot enter.

To cancel the password protection function, set 08-00 to 0. The user password does not protect the parameters in the shortcut menu.

Exit the function code editing state, the user password is locked immediately, and the user password is required to enter again.

3.2.5 Running State

3.2.5.1 Power on Initialization

On the course of inverter power on, the system is initialized firstly, LED displays "- - - -" with 7 indicators on. The inverter is in standby state after finishing initialization.

3.2.5.2 Standby

Under stop or running status, various status parameters can be displayed. The function code 08-03 / 08-04 (operation parameter) and 08-05 (stop parameter) can be used to select whether to display this parameter according to the binary digits. Please refer to the descriptions of 08-03, 08-04 and 08-05 for the definition of each bit .

In the stop state, there are 12 stop state parameters that can be selected to be displayed or not, which are: set frequency, bus voltage, switch input state, open collector output state, analog input AVI1 voltage, analog input AVI2 voltage, count value, The length value, the number of PLC segments, the load speed, the PID setting, and the PULSE input pulse frequency are selected by function code 08-05 by bit (converted to binary). ENT + QUICK / JOG key to switch to the left to display selected parameters.

3.2.5.3 Motor Parameters Self-learning

Please see the description of function code 01-01 for details.

3.2.5.4 Operation

In the running state, there are 28 state parameters that can be selected to be displayed or not, respectively: running frequency, set frequency, bus voltage, output voltage, output current, output power, output torque, MI input status, MO output status, AVI1 Voltage, AVI2 voltage, count value, length value, load speed display, PID setting, PID feedback, PLC segments, PULSE input pulse frequency, operating frequency 2, remaining operating time, voltage before AVI1 correction, voltage before AVI2 / ACI correction, Line speed, current power-on time, current running time, communication setting value, main frequency X display, auxiliary frequency Y display. Whether to display is selected bit by bit (converted to binary) by function code 08-03 / 08-04, press " > "Key sequence switch to display the selected parameter, press DATA / ENT + QUICK / JOG key to switch to display the selected parameter to the left in order.

3.2.5.5 Alarms

S3100A series inverter provides of alarm information. Please see the alarms and solutions of S3100A series inverter for details.

3.2.6 Quick Debugging

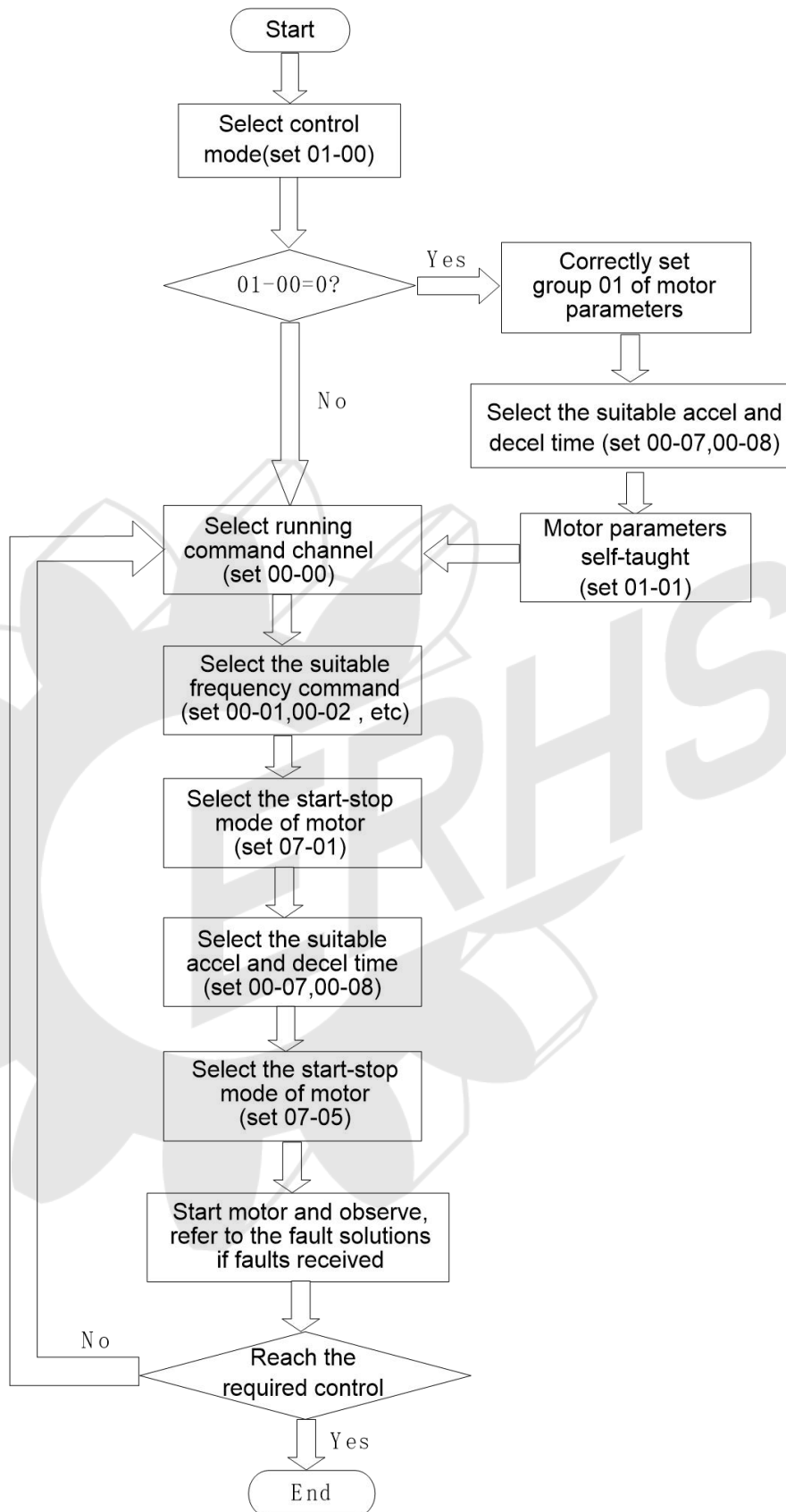

3.3 Preliminary Operation-not Connecting With Motor

- Prior to connecting power supply with AC motor drive, check and make sure that AC power supply voltage is within input voltage range of the drive.
- Connect power supply to R/L1,S/L2 and T/L3 input terminals of the AC motor drive.
- Operation mode control selection.

Operation mode can be divided into the following categories:

- Both frequency command and operation control are determined by keyboard. (00-00=0) (Factory setting)

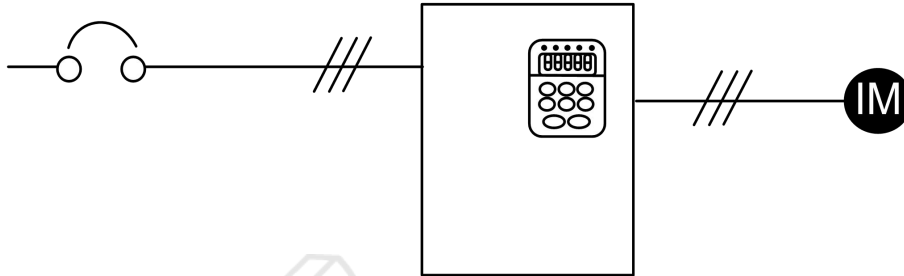

- Frequency command is controlled by keyboard.

Operation command is controlled by external terminals. STOP key on keyboard valid.

Two wire operation control, "FWD/STOP" and "REV/STOP"(04-00=1, 04-01=2, 04-09=0 or 1)

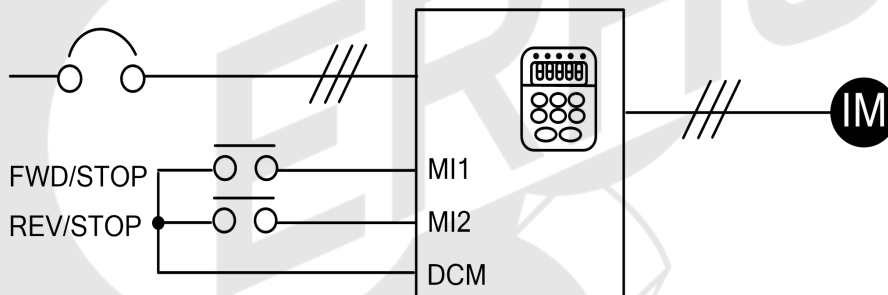

- Frequency command is controlled by keyboard.

Three wire operation control mode Configuration 1 (04-00=1, 04-01=2, 04-02=3, 04-09=2)

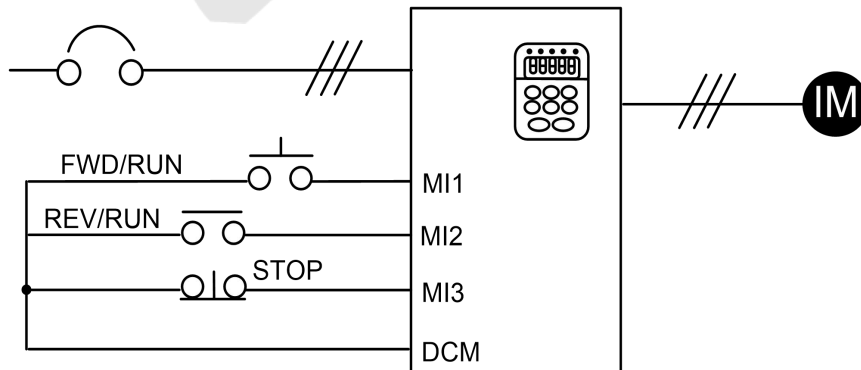

- Frequency command is controlled by keyboard.

Three wire operation control mode Configuration 2 (04-00=1, 04-01=3, 04-02=2, 04-09=3)

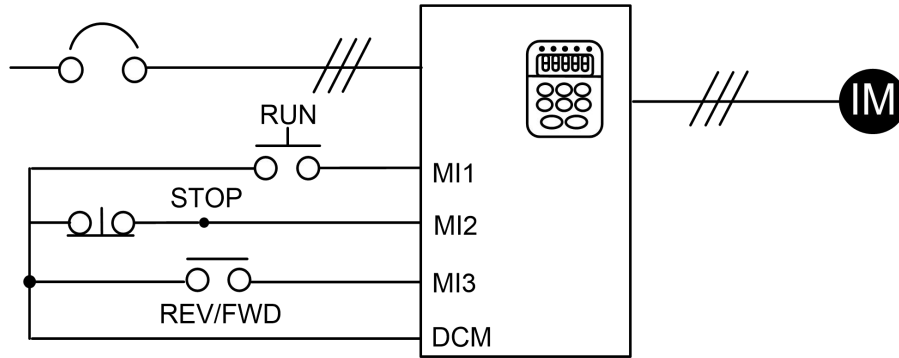

- Frequency command is input by analog signals.

(DC 0 to +10V)+(DC 4 to 20mA)

Operation command is controlled by keyboard.(00-02 is set as 1,2)

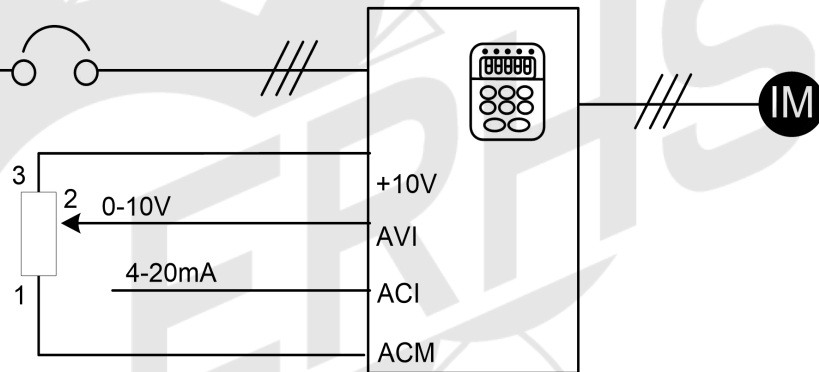

4 FUNCTION PARAMETERS LIST

00 Basic functions parameters		↗ indicates that the parameters can be set during operation.		
Parameter	Parameter function	Setting range	Factory setting	
00-00	Command source selection	0:Keyboard command (LED off) 1:Terminal command (LED on) 2:Communication command (LED flicker)	0	↗
00-01	Keyboard and terminal UP / DOWN setting selection	0:Stop memory and power failure storage 1:Stop memory 2:Stop no memory	2	↗
00-02	Main Frequency source selection	0:Digital setting (keyboard given frequency 00-06, UP /DOWN can be modified) 1:AVI1 2:AVI2 / ACI 3:Reserved 4:Multi-speed command 5:PID control 6:Communication setting 7:Simple PLC 8:Panel potentiometer 9:Pulse setting (MI5)	1	
00-03	Maximum frequency	50.00Hz~500.00Hz	50.00Hz	
00-04	Upper limitation of running frequency	Lower limit frequency 00-05 ~max frequency 00-03	50.00Hz	↗
00-05	Lower limitation of running frequency	0.00Hz ~ Upper limit frequency	0.00Hz	↗
00-06	Keyboard setting frequency	0.00Hz to the maximum frequency (00-03)	50.00Hz	↗
00-07	Acceleration time 1	0.00s~65000s	Type setting	↗
00-08	Deceleration time 1	0.00s~65000s	Type setting	↗
00-09	Operation direction	0: Forward 1: Reverse	0	↗
00-10	Carrier frequency	0.5kHz~16.0kHz	Type setting	↗
00-11	Parameter initialization	0:No operation 1:Restore factory parameters, excluding motor parameters 2:Clear record information	0	
00-12	Carrier frequency adjustment	0: No automatic carrier reduction 1: Automatic carrier reduction 2: Low noise	1	↗
00-13	G/P setting	1:G type (constant torque load model) 2:P type (fan, pump type)	1	
00-14	Auxiliary frequency source Y selection	Same as 00-02 (Main frequency source X selection)	0	
00-15	Auxiliary frequency source Y range selection during superposition	0:Relative to the maximum frequency 1:Relative to frequency source X	0	↗

00 Basic functions parameters

⚡ indicates that the parameters can be set during operation.

Parameter	Parameter function	Setting range	Factory setting	
00-16	Auxiliary frequency source Y range when superimposed	0%~150%	100%	⚡
00-17	Frequency source selection	Single digit:Frequency source selection 0:Main frequency source X 1:Main and auxiliary calculation results (Operation relationship is determined by ten digits) 2:Switch between the main frequency source X and the auxiliary frequency source Y 3:Switch between the main frequency source X and the main and auxiliary calculation results 4:Switch between auxiliary frequency source Y and main and auxiliary calculation results Tens digit:the relationship between the main and auxiliary operations of the frequency source 0:Main+auxiliary 1:Main-auxiliary 2:Maximum of both 3:Minimum of both	0	⚡
00-19	Auxiliary frequency source offset frequency when superimposed	0.00Hz to the maximum frequency (00-03)	0.00Hz	⚡
00-20	Upper frequency source	0:00-04 setting 1:AVI1 2:AVI2 / ACI 3:reserved 4:PULSE pulse setting 5:Communication given	0	
00-21	Upper frequency offset	0.00Hz~Max frequency 00-03	0.00Hz	⚡
00-22	Acceleration / deceleration time unit	0:1s 1:0.1s 2:0.01s	1	
00-23	Base frequency of acceleration and deceleration time	0:Maximum frequency (00-03) 1:set frequency 2:100Hz	0	
00-24	Base frequency for UP/DOWN command during running	0:Running frequency 1:Set frequency 2:When stop,the frequency can not be changed 3:When stop,up down cleared	1	
00-25	Frequency command resolution	1:0.1Hz 2:0.01Hz	2	

01 Motor control parameters

↗ indicates that the parameters can be set during operation.

Parameter	Parameter function	Setting range	Factory setting	
01-00	The first motor control mode	0:Speed sensorless vector control (SVC) 2:V/f control	0	
01-01	Motor parameter self-learning	0:No self-learning 1:Asynchronous motor static self-learning 2:Asynchronous motor complete self-learning	0	
01-02	Motor rated power	0.1kW~1000.0kW	Type setting	
01-03	Motor rated frequency	0.01Hz~max frequency	Type setting	
01-04	Motor rated rotation speed	1rpm~65535rpm	Type setting	
01-05	Motor rated voltage	1V~2000V	Type setting	
01-06	Motor rated current	0.01A~655.35A(inverter power <=55kW) 0.1A~6553.5A(inverter power >55kW)	Type setting	
01-07	Stator resistance of asynchronous motor	0.001Ω~65.535Ω(inverter power <=55kW) 0.0001Ω~6.5535Ω(inverter power >55kW)	Type setting	
01-08	Rotor resistance of asynchronous motor	0.001Ω~65.535Ω(inverter power <=55kW) 0.0001Ω~6.5535Ω(inverter power >55kW)	Type setting	
01-09	Leakage inductance of asynchronous motor	0.01mH~655.35mH(inverter power <=55kW) 0.001mH~65.535mH(inverter power >55kW)	Type setting	
01-10	Mutual inductance of asynchronous motor	0.1mH~6553.5mH(inverter power <=55kW) 0.01mH~655.35mH(inverter power >55kW)	Type setting	
01-11	No-load current of asynchronous motor	0.01A~01-06(inverter power <=55kW) 0.1A~01-06(inverter power >55kW)	Type setting	
01-12	Motor type selection	0:ordinary asynchronous motor 1:Frequency conversion asynchronous motor	0	

02 Vector control parameters

↗ indicates that the parameters can be set during operation.

Parameter	Parameter function	Setting range	Factory setting	
02-00	Speed loop proportional gain 1	1~100	30	↗
02-01	Speed loop integration time 1	0.01s~10.00s	0.50s	↗
02-02	Switching frequency 1	0.00~02-05	5.00Hz	↗
02-03	Speed loop proportional gain 2	1~100	20	↗
02-04	Speed loop integration time 2	0.01s~10.00s	1.00s	↗
02-05	Switching frequency 2	02-02~max frequency	10.00Hz	↗
02-06	Vector control slip gain	50%~200%	100%	↗
02-07	Digital setting of torque upper limit in speed control mode	0.0%~200.0%	150.0%	↗
02-08	Speed loop filter time constant	0.000s~0.100s	0.015s	↗
02-09	Vector control over excitation gain	0~200	64	↗

02 Vector control parameters

↗ indicates that the parameters can be set during operation.

Parameter	Parameter function	Setting range	Factory setting	
02-10	Torque upper limit source in speed control mode	0:Parameter 02-07 setting 1:AVI1 2:AVI2 / ACI 3:reserved 4:PULSE pulse setting 5:Communication setting 6:MIN (AVI1, AVI2 / ACI) 7:MAX (AVI1, AVI2 / ACI) The full scale of the 1-7 option corresponds to 02-07	0	↗
02-13	Excitation adjustment proportional gain	0~60000	2000	↗
02-14	Excitation adjustment integral gain	0~60000	1300	↗
02-15	Torque adjustment proportional gain	0~60000	2000	↗
02-16	Torque adjustment integral gain	0~60000	1300	↗
02-17	Velocity loop integral properties	Single unit: integral separation 0: invalid 1: valid	0	↗

03 V/f control parameters

↗ indicates that the parameters can be set during operation.

Parameter	Parameter function	Setting range	Factory setting	
03-00	V/f curve setting	0: Straight line V/f 1: Multi-point V/f 2: Square 2.0 3: 1.2 power V/f 4: 1.4 power V/f 6: 1.6 power V/f 8: 1.8 power V/f 9: Reserved 10: V/f complete separation mode 11: V/f half separation mode	0	
03-01	Torque boost	0.0%:(auto-torque boost) 0.1%~30.0%	Type setting	↗
03-02	Cut-off frequency of torque boost	0.00Hz~max frequency	50.00Hz	
03-03	Multi-point V/f frequency 1	0.00Hz~03-05	0.00Hz	
03-04	Multi-point V/f voltage 1	0.0%~100.0%	0.0%	
03-05	Multi-point V/f frequency 2	03-03~03-07	0.00Hz	
03-06	Multi-point V/f voltage 2	0.0%~100.0%	0.0%	
03-07	Multi-point V/f frequency 3	03-05~motor rated frequency(01-03)	0.00Hz	
03-08	Multi-point V/f voltage 3	0.0%~100.0%	0.0%	
03-09	V/f slip compensation gain	0.0%~200.0%	0.0%	↗

03 V/f control parameters

⚡ indicates that the parameters can be set during operation.

Parameter	Parameter function	Setting range	Factory setting	
03-10	V/f overexcitation gain	0~200	64	⚡
03-11	V/f oscillation suppression gain	0~100	Type setting	⚡
03-13	V/f separated voltage source	0:Digital setting (03-14) 1:AVI1 2:AVI2 / ACI 3:Reserved 4:Pulse setting (MI5) 5:Multi-speed command 6:Simple PLC 7:PID 8:Communication setting Note:100.0% corresponds to the rated voltage of the motor.	0	⚡
03-14	Voltage digital setting of V/f detached	0V~motor rated voltage	0V	⚡
03-15	V/f separated voltage rise time	0.0s~1000.0s Note:It means the time from 0V to the rated voltage of the motor.	0.0s	⚡
03-16	Voltage deceleration time for V/f separation	0.0s~1000.0s Note: indicates the time from 0V to the rated voltage of the motor	0.0s	⚡
03-17	V/f separation stop mode selection	0: Frequency/voltage is reduced to 1: The frequency is reduced after the voltage is reduced to 0	0	
03-18	Over current stall action current	50~200%	150%	
03-19	Overflow rate enable	0: invalid 1: valid	1	
03-20	Over-current stall suppression gain	0~100	20	⚡
03-21	Double-speed over-current stall action current compensation coefficient	50~200%	50%	
03-22	Overvoltage stall action voltage	330.0V~800.0V	380V: 760.0 220V: 370.0	
03-23	Overvoltage stall enable	0: invalid 1: valid	1	
03-24	Overvoltage stall suppression frequency gain	0~100	30	⚡
03-25	Overvoltage stall suppression voltage gain	0~100	30	⚡
03-26	Overvoltage stall maximum rise frequency limit	0~50Hz	5Hz	

04 Input terminal parameters

✎ indicates that the parameters can be set during operation.

Parameter	Parameter function	Setting range	Factory setting	
04-00	MI1 Terminal function selection	0:No function	1	
04-01	MI2 Terminal function selection	1:Forward running (FWD)	2	
04-02	MI3 Terminal function selection	2:Reverse running (REV)	9	
04-03	MI4 Terminal function selection	3:Three-wire control	0	
04-04	MI5 Terminal function selection (high-speed pulse optional)	4:Forward Jog (FJOG)	0	
04-05	Reserved	5:Reverse jog (RJOG)	0	
04-06	Reserved	6:Terminal UP	0	
04-07	Reserved	7:Terminal DOWN	0	
		8:Coast to stop	0	
		9:Fault reset (RESET)	0	
		10:Run pause		
		11:Normally open input for external fault		
		12:Multi-step speed command terminal 1		
		13:Multi-step speed command terminal 2		
		14:Multi-step speed command terminal 3		
		15:Multi-step speed command terminal 4		
		16:Acceleration / deceleration time selection terminal 1		
		17:Acceleration / deceleration time selection terminal 2		
		18:Frequency source switching		
		19:UP / DOWN set to cleared (Terminal, keyboard)		
		20:Run command switching terminal		
		21:Acceleration / deceleration prohibited		
		22:PID pause		
		23:PLC status reset		
		24:Wobble frequency pause		
		25:Counter input		
		26:Counter reset		
		27:Length count input		
		28:Length reset		
		29:Torque control prohibited		
		30:PULSE (pulse) frequency input (MI5)		
		31:reserved		
		32:Immediate DC braking		
		33:Normally closed input for external fault		
		34:Frequency modification enable		
		35:PID action direction is reversed		
		36:External stop terminal 1		
		37:Control command switching terminal 2		
		38:PID integration pause		
		39:Frequency source X and keyboard set frequency switching		
		40:Frequency source Y and keyboard set frequency switching		
		41:Reserved		
		42:Reserved		
		43:PID parameter switching		
		44:Reserved		
		45:reserved		

04 Input terminal parameters

↗ indicates that the parameters can be set during operation.

Parameter	Parameter function	Setting range	Factory setting	
		46:Speed control / torque control switching 47:Emergency stop 48:External stop terminal 2 49:Deceleration DC braking 50:Clear the current running time 51-63:reserved		
04-08	MI Filter time	0.000s~1.000s	0.010s	↗
04-09	Terminal command mode	0:Two-wire 1 1:Two-wire 2 2:Three-wire 1 3:Three-wire 2 4:Four-wire 1	0	
04-10	Terminal UP / DOWN change rate	0.001Hz/s~65.535Hz/s	1.00Hz/s	↗
04-11	AVI curve 1 lower limit	0.00V~04-13	0.10V	↗
04-12	Corresponding setting of AVI curve 1 lower limit	-100.0%~+100.0%	0.0%	↗
04-13	AVI curve 1 upper limit	04-11~+10.00V	10.00V	↗
04-14	Corresponding setting of AVI curve 1 upper limit	-100.0%~+300.0%	100.0%	↗
04-15	AVI1 filter time	0.00s~10.00s	0.10s	↗
04-16	AVI curve 2 lower limit	0.00V~04-18	1.00V	↗
04-17	Corresponding setting of AVI curve 2 lower limit	-100.0%~+100.0%	0.0%	↗
04-18	AVI curve 2 upper limit	04-16~+10.00V	5.00V	↗
04-19	Corresponding setting of AVI curve 2 upper limit	-100.0%~+300.0%	100.0%	↗
04-20	AVI2/ACI filter time	0.00s~10.00s	0.10s	↗
04-23	Panel potentiometer curve lower limit value	-10.00V~04-25	0.10V	↗
04-24	Corresponding setting of panel potentiometer curve lower limit value	-100.0%~+100.0%	0.0%	↗
04-25	Panel potentiometer curve upper limit value	04-23~+10.00V	9.90V	↗
04-26	Corresponding setting of Panel potentiometer curve upper limit value	-100.0%~+150.0%	100.0%	↗
04-27	Filter time of Panel potentiometer	0.00s~10.00s	0.10s	↗
04-28	Pulse minimum input	0.00kHz~04-30	0.00kHz	↗
04-29	Corresponding setting of pulse minimum input	-100.0%~100.0%	0.0%	↗
04-30	Pulse maximum input	04-28~100.00kHz	50.00kHz	↗

04 Input terminal parameters

⚡ indicates that the parameters can be set during operation.

Parameter	Parameter function	Setting range	Factory setting	
04-31	Corresponding setting of pulse maximum input	-100.0%~100.0%	100.0%	⚡
04-32	PULSE filter time	0.00s~10.00s	0.10s	⚡
04-33	AVI curve selection	Single digit:AVI1 curve selection 1:AVI curve 1 (2 points, see 04-11~04-14) 2:AVI curve 2 (2 points, see 04-16~04-19) 3:Reserved 4:Reserved 5:Reserved Tenth digit:AVI2 / ACI curve selection, same as above Hundreds digit:Reserved	321	⚡
04-34	AVI is less than the minimum input setting selection	Single digit:AVI1 is below the minimum input setting selection 0:Corresponds to the minimum input setting 1:0.0% Tens digit:AVI2 / ACI is lower than the minimum input setting selection, same as above	000	⚡
04-35	MI1 delay time	0.0s~3600.0s	0.0s	⚡
04-36	MI2 delay time	0.0s~3600.0s	0.0s	⚡
04-37	MI3 delay time	0.0s~3600.0s	0.0s	⚡
04-38	MI terminal valid mode selection 1	0:High level valid 1:Low level valid Single digit:MI1 Tens digit:MI2 Hundreds digit :MI3 Thousands digit:MI4 Tens of thousands digit :MI5	0	

05 Multi-speed, simple PLC control

⚡ indicates that the parameters can be set during operation.

Parameter	Parameter function	Setting range	Factory setting	
05-00	Multi-speed command 0	-100.0%~100.0%	0.0%	⚡
05-01	Multi-speed command 1	-100.0%~100.0%	0.0%	⚡
05-02	Multi-speed command 2	-100.0%~100.0%	0.0%	⚡
05-03	Multi-speed command 3	-100.0%~100.0%	0.0%	⚡
05-04	Multi-speed command 4	-100.0%~100.0%	0.0%	⚡
05-05	Multi-speed command 5	-100.0%~100.0%	0.0%	⚡
05-06	Multi-speed command 6	-100.0%~100.0%	0.0%	⚡
05-07	Multi-speed command 7	-100.0%~100.0%	0.0%	⚡

05 Multi-speed, simple PLC control

↗ indicates that the parameters can be set during operation.

Parameter	Parameter function	Setting range	Factory setting	
05-08	Multi-speed command 8	-100.0%~100.0%	0.0%	↗
05-09	Multi-speed command 9	-100.0%~100.0%	0.0%	↗
05-10	Multi-speed command 10	-100.0%~100.0%	0.0%	↗
05-11	Multi-speed command 11	-100.0%~100.0%	0.0%	↗
05-12	Multi-speed command 12	-100.0%~100.0%	0.0%	↗
05-13	Multi-speed command 13	-100.0%~100.0%	0.0%	↗
05-14	Multi-speed command 14	-100.0%~100.0%	0.0%	↗
05-15	Multi-speed command 15	-100.0%~100.0%	0.0%	↗
05-16	Simple PLC operation mode	0:Stop at the end of a single run 1:Keep the final value at the end of a single run 2:keep circulating	0	↗
05-17	Simple PLC power-down memory selection	Single digit:Power failure memory selection 0:Power failure no memory 1:Power failure memory Tenth digit:Stop memory selection 0:Stop no memory 1:Stop memory	0	↗
05-18	Simple PLC stage 0 running time	0.0s(h)~6500.0s(h)	0.0s(h)	↗
05-19	Simple PLC step 0 acceleration / deceleration time selection	0~3	0	↗
05-20	Simple PLC stage 1 st running time	0.0s(h)~6500.0s(h)	0.0s(h)	↗
05-21	Simple PLC step 1 st acceleration / deceleration time selection	0~3	0	↗
05-22	Simple PLC stage 2 nd running time	0.0s(h)~6500.0s(h)	0.0s(h)	↗
05-23	Simple PLC step 2 nd acceleration / deceleration time selection	0~3	0	↗
05-24	Simple PLC stage 3 rd running time	0.0s(h)~6500.0s(h)	0.0s(h)	↗
05-25	Simple PLC step 3 rd acceleration / deceleration time selection	0~3	0	↗
05-26	Simple PLC stage 4 th running time	0.0s(h)~6500.0s(h)	0.0s(h)	↗
05-27	Simple PLC step 4 th acceleration / deceleration time selection	0~3	0	↗
05-28	Simple PLC stage 5 th running time	0.0s(h)~6500.0s(h)	0.0s(h)	↗
05-29	Simple PLC step 5 th acceleration / deceleration time selection	0~3	0	↗
05-30	Simple PLC stage 6 th running time	0.0s(h)~6500.0s(h)	0.0s(h)	↗
05-31	Simple PLC step 6 th acceleration / deceleration time selection	0~3	0	↗
05-32	Simple PLC stage 7 th running time	0.0s(h)~6500.0s(h)	0.0s(h)	↗

05 Multi-speed, simple PLC control

↗ indicates that the parameters can be set during operation.

Parameter	Parameter function	Setting range	Factory setting	
05-33	Simple PLC step 7 th acceleration / deceleration time selection	0~3	0	↗
05-34	Simple PLC stage 8 th running time	0.0s(h)~6500.0s(h)	0.0s(h)	↗
05-35	Simple PLC step 8 th acceleration / deceleration time selection	0~3	0	↗
05-36	Simple PLC stage 9 th running time	0.0s(h)~6500.0s(h)	0.0s(h)	↗
05-37	Simple PLC step 9 th acceleration / deceleration time selection	0~3	0	↗
05-38	Simple PLC stage 10 th running time	0.0s(h)~6500.0s(h)	0.0s(h)	↗
05-39	Simple PLC step 10 th acceleration / deceleration time selection	0~3	0	↗
05-40	Simple PLC stage 11 th running time	0.0s(h)~6500.0s(h)	0.0s(h)	↗
05-41	Simple PLC step 11 th acceleration / deceleration time selection	0~3	0	↗
05-42	Simple PLC stage 12 th running time	0.0s(h)~6500.0s(h)	0.0s(h)	↗
05-43	Simple PLC step 12 th acceleration / deceleration time selection	0~3	0	↗
05-44	Simple PLC stage 13 th running time	0.0s(h)~6500.0s(h)	0.0s(h)	↗
05-45	Simple PLC step 13 th acceleration / deceleration time selection	0~3	0	↗
05-46	Simple PLC stage 14 th running time	0.0s(h)~6500.0s(h)	0.0s(h)	↗
05-47	Simple PLC step 14 th acceleration / deceleration time selection	0~3	0	↗
05-48	Simple PLC stage 15 th running time	0.0s(h)~6500.0s(h)	0.0s(h)	↗
05-49	Simple PLC step 15 th acceleration / deceleration time selection	0~3	0	↗
05-50	Simple PLC running time unit	0:s(second) 1:h(hour)	0	↗
05-51	Multi-step speed command 0 given mode	0:Parameter 05-00 given 1:AVI1 2:AVI2 / ACI 3:reserved 4:PULSE 5:PID 6:The keyboard setting frequency (00-06) is given, UP /DOWN can be modified	0	↗

06 Output terminal parameters

⚡ indicates that the parameters can be set during operation.

Parameter	Parameter function	Setting range	Factory setting	
06-00	MO1 output function selection	0:No output	1	⚡
06-01	Control board relay function selection (RA-RB-RC)	1:Inverter is running 2:Fault output (stop)	2	⚡
06-02	Relay 2 function selection	3:Frequency level detection FDT1 output 4:Frequency reached	0	⚡
06-03	Reserved	5:Running at zero speed (no output when stopped)		⚡
06-04	DFM (M) output function selection	6:Motor overload pre-alarm 7:Inverter overload pre-alarm 8:Set count value reached 9:Designated count value reached 10:Length reached 11:PLC cycle completed 12:Cumulative running time arrived 13:Frequency limited 14:Torque limited 15:Ready for run 16:AVI1> AVI2 / ACI 17:Upper limit frequency reached 18:Lower limit frequency reached (operation valid) 19:Undervoltage state output 20:Communication setting 21:(reserved) 22:(Reserved) 23:Zero speed running 2 (also output when stopped) 24:Cumulative power-on time arrived 25:Frequency level detection FDT2 output 26:Frequency 1 reaches the output 27:Frequency 2 reaches the output 28:Current 1 reaches the output 29:Current 2 reaches the output 30:Timing reached 31:AVI1 input exceeds limit 32:Lost load 33:Reverse running 34:Zero current state 35:Module temperature reached 36:Output current exceeded 37:Lower limit frequency reached (also output when stopped) 38:Warning output (continued) 39:reserved 40:Current running time reached 41-44: reserved	0	⚡

06 Output terminal parameters

⚡ indicates that the parameters can be set during operation.

Parameter	Parameter function	Setting range	Factory setting	
06-05	DFM terminal output mode selection	0:Pulse output (DFM (P)) 1:Switch output (DFM (M))	0	⚡
06-06	DFM (P) output function selection	0:Running frequency	0	⚡
06-07	AFM output function selection	1:Set frequency 2:Output current	0	⚡
06-08	AFM2 option of the output function (it is optional for large kW)	3:Output torque 4:Output power 5:Output voltage 6:PULSE input (100.% corresponds to 100.0kHz) 7:AVI1 8:AVI2 / ACI 9:Reserved 10:Length 11:Count value 12:Communication setting 13:Motor rotation speed 14:Output current (100.0% corresponds to 1000.0A) 15:BUS voltage (100.0% corresponds to 1000.0V) 16-22:Reserved	1	⚡
06-09	DFM (P) output maximum frequency	0.01kHz~100.00kHz	50.00kHz	⚡
06-10	AFM zero offset coefficient	-100.0%~+100.0%	0.0%	⚡
06-11	AFM gain	-10.00~+10.00	1.00	⚡
06-12	AFM2 zero offset coefficient	-100.0%~+100.0%	0.0%	⚡
06-13	AFM2 gain	-10.00~+10.00	1.00	⚡
06-17	MO1 output delay time	0.0s~3600.0s	0.0s	⚡
06-18	Relay RA-RB-RC output delay time	0.0s~3600.0s	0.0s	⚡
06-19	Relay 2 output delay time	0.0s~3600.0s	0.0s	⚡
06-20	Reserved			⚡
06-21	DFM (M) output delay time	0.0s~3600.0s	0.0s	⚡
06-22	MO output terminal valid state selection	0:Positive logic 1:Negative logic Single digit:MO1 Tenth digit:relay RA-RB-RC Hundreds digit:reserved Thousands digit:reserved Tens of thousands digit :DFM(M)	0	⚡
06-23	Reserved		0	

07 Start and stop control parameters

↗ indicates that the parameters can be set during operation.

Parameter	Parameter function	Setting range	Factory setting	
07-00	Startup mode	0:Direct start 1:Rotation speed tracking restart 2:Pre-excitation start 3:Reserved	0	
07-01	Startup frequency	0.00Hz~10.00Hz	0.00Hz	↗
07-02	Startup frequency holding time	0.0s~100.0s	0.0s	
07-03	Startup DC braking current / pre-excitation current	0%~100%	0%	
07-04	Startup DC braking time / pre-excitation time	0.0s~100.0s	0.0s	
07-05	Stop mode	0:Decelerate to stop 1:Coast to stop	0	↗
07-06	Starting DC braking frequency at stop	0.00Hz~max frequency	0.00Hz	↗
07-07	DC braking waiting time at stop	0.0s~100.0s	0.0s	↗
07-08	DC braking current at stop	0%~100%	50%	↗
07-09	DC braking time at stop	0.0s~100.0s	0.0s	↗
07-10	Brake usage	0%~100%	80%	↗
07-11	Acceleration and deceleration mode	0:linear acceleration / deceleration 1:S curve acceleration and deceleration A 2:S curve acceleration / deceleration B	0	
07-12	S curve start time ratio	0.0%~(100.0%-07-13)	30.0%	
07-13	S curve end time ratio	0.0%~(100.0%-07-12)	30.0%	
07-14	Rotation speed tracking mode	0:Start from stop frequency 1:Start from zero speed 2:Start from maximum frequency	0	↗
07-15	Rotation speed tracking speed	1~100	20	

08 Man-machine interface parameters

↗ indicates that the parameters can be set during operation.

Parameter	Parameter function	Setting range	Factory setting	
08-00	User password	0~65535	0	↗
08-01	QUICK/JOG key function selection	0:QUICK/JOG invalid 1:Keyboard command channel and remote command channel (terminal Terminal command channel or communication command channel) switch 2:Forward and reverse switching 3:Forward jog 4:Reverse jog 5:Counter 2 cleared	3	

08 Man-machine interface parameters

⚡ indicates that the parameters can be set during operation.

Parameter	Parameter function	Setting range	Factory setting	
08-02	STOP/RESET key function	0:Only in the keyboard operation mode, the STOP/RESET key stop function is effective 1:In any operation mode, the STOP/RESET key stop function is effective	1	⚡
08-03	LED operation display parameter 1	0000~FFFF Bit00:Running frequency 1(Hz) Bit01:Setting frequency(Hz) Bit02:BUS Voltage(V) Bit03:Output voltage(V) Bit04:Output current(A) Bit05:Output power(kW) Bit06:Output torque(%) Bit07:MI input status Bit08:MO output status Bit09:AVI1 voltage(V) Bit10:AVI2/ACI voltage(V) Bit11:Reserved Bit12:Count value Bit13:Length Bit14:Load speed Bit15:PID setting	1F	⚡
08-04	LED operation display parameter 2	0000~FFFF Bit00:PID feedback Bit01:PLC stage Bit02:PULSE input pulse frequency(kHz) Bit03:Running frequency 2(Hz) Bit04:Remaining running time Bit05:AVI1 voltage before correction(V) Bit06:AVI2/ACI voltage before correction(V) Bit07:Counter 2 Bit08:Line speed Bit09:Current power-on time(Hour) Bit10:Current running time(Min) Bit11:PULSE input pulse frequency(Hz) Bit12:Communication setting value Bit13:Reserved Bit14:Main frequency X display (Hz) Bit15:Auxiliary frequency Y display(Hz)	0	⚡
08-05	LED shutdown display parameters	0000~FFFF Bit00:Setting frequency(Hz) Bit01:BUS voltage(V) Bit02:MI input status Bit03:MO output status Bit04:AVI1 voltage(V) Bit05:AVI2/ACI voltage(V) Bit06:Reserved Bit07:Count value Bit08:Length Bit09:PLC stage	33	⚡

08 Man-machine interface parameters

⚡ indicates that the parameters can be set during operation.

Parameter	Parameter function	Setting range	Factory setting	
		Bit10:Load speed Bit11:PID setting Bit12:PULSE input pulse frequency(kHz) Bit13:Counter 2		
08-06	Load speed display coefficient	0.0001~6.5000	1	⚡
08-07	Reserved		-	
08-08	Inverter module radiator temperature	0.0°C~100.0°C	-	
08-09	Reserved	-	-	
08-10	Software version No.	-	-	
08-11	Cumulative running time	0h~65535h	-	
08-12	Load speed display the number of decimal places	Units: Number of decimal places for load speed Tens place: Number of decimal places for feedback speed 0:0 decimal place 1:1 decimal place 2:2 decimal places 3:3 decimal places	20	⚡
08-13	Cumulative power-on time	0h~65535h	-	
08-14	Cumulative power consumption	0~65535 degree	-	

09 Accessibility parameters

⚡ indicates that the parameters can be set during operation.

Parameter	Parameter function	Setting range	Factory setting		
09-00	Jog running frequency	0.00Hz~max frequency	5.00Hz	⚡	
09-01	Jog acceleration time	0.0s~6500.0s	20.0s	⚡	
09-02	Jog deceleration time	0.0s~6500.0s	20.0s	⚡	
09-03	Acceleration time 2	0.0s~6500.0s	Type setting	⚡	
09-04	Deceleration time 2	0.0s~6500.0s		⚡	
09-05	Acceleration time 3	0.0s~6500.0s		⚡	
09-06	Deceleration time 3	0.0s~6500.0s		⚡	
09-07	Acceleration time 4	0.0s~6500.0s		⚡	
09-08	Deceleration time 4	0.0s~6500.0s		⚡	
09-09	Jump frequency 1	0.00Hz~max frequency		0.00Hz	⚡
09-10	Jump frequency 2	0.00Hz~max frequency		0.00Hz	⚡
09-11	Jump frequency Amplitude	0.00Hz~max frequency	0.00Hz	⚡	
09-12	Forward and reverse dead time	0.0s~3000.0s	0.0s	⚡	
09-13	Reverse control enable	0:Enabled 1:Disabled	0	⚡	

09 Accessibility parameters

↗ indicates that the parameters can be set during operation.

Parameter	Parameter function	Setting range	Factory setting	
09-14	Operating mode with set frequency lower than lower limit frequency	0:Run at the lower limit frequency 1:Downtime 2:Zero speed operation	0	↗
09-15	Drop control	0.00Hz~10.00Hz	0.00Hz	↗
09-16	Set cumulative power-on arrival time	0h~65000h	0h	↗
09-17	Set cumulative running arrival time	0h~65000h	0h	↗
09-18	Power-on operation protection options	0:Run command is valid when power on 1:Run command is invalid when power on	1	↗
09-19	Frequency detection value(FDT1)	0.00Hz~max frequency	50.00Hz	↗
09-20	Frequency detection hysteresis(FDT1)	0.0%~100.0%(FDT1 Level)	5.0%	↗
09-21	Frequency reach detection width	0.0%~100.0%(max frequency)	0.0%	↗
09-22	Whether the jump frequency is effective during acceleration and deceleration	0:Invalid 1:Valid	0	↗
09-25	Switching frequency point between acceleration time 1 and acceleration time 2	0.00Hz~max frequency	0.00Hz	↗
09-26	Switching frequency point between deceleration time 1 and deceleration time 2	0.00Hz~max frequency	0.00Hz	↗
09-27	Terminal jogging priority	0:Invalid 1:Valid	0	↗
09-28	Frequency detection value(FDT2)	0.00Hz~max frequency	50.00Hz	↗
09-29	Frequency detection hysteresis(FDT2)	0.0%~100.0%(FDT2 Level)	5.0%	↗
09-30	Arbitrary arrival frequency detection value 1	0.00Hz~max frequency	50.00Hz	↗
09-31	Arbitrary arrival frequency detection width 1	0.0%~100.0%(max frequency)	0.0%	↗
09-32	Arbitrary arrival frequency detection value 2	0.00Hz~max frequency	50.00Hz	↗
09-33	Arbitrary arrival frequency detection width 2	0.0%~100.0%(max frequency)	0.0%	↗
09-34	Zero current detection level	0.0%~300.0% 100.0% corresponds to the rated current of the motor	5.0%	↗
09-35	Zero current detection delay time	0.01s~600.00s	0.10s	↗
09-36	Output current limit	0.0%(No detection) 0.1%~300.0%(motor rated current)	200.0%	↗

09 Accessibility parameters

↗ indicates that the parameters can be set during operation.

Parameter	Parameter function	Setting range	Factory setting	
09-37	Output overcurrent detection delay time	0.00s~600.00s	0.00s	↗
09-38	Arbitrary arrival current 1	0.0%~300.0%(motor rated current)	100.0%	↗
09-39	Arbitrary arrival current 1 width	0.0%~300.0%(motor rated current)	0.0%	↗
09-40	Arbitrary arrival current 2	0.0%~300.0%(motor rated current)	100.0%	↗
09-41	Arbitrary arrival current 2 width	0.0%~300.0%(motor rated current)	0.0%	↗
09-42	Timing function selection	0:Invalid 1:Valid	0	
09-43	Timed running time selection	0:09-44 setting 1:AVI1 2:AVI2/ACI 3:Reserved Analog input range corresponds to 09-44	0	
09-44	Timed running time	0.0Min~6500.0Min	0.0Min	
09-45	Lower limit of AVI1 input voltage protection value	0.00V~09-46	3.10V	↗
09-46	Upper limit of AVI1 input voltage protection value	09-45~11.00V	6.80V	↗
09-47	Module temperature reached	0°C~100°C	75°C	↗
09-48	Cooling fan control	0:Fans run during operation 1:The fan keeps running	0	
09-49	Wake frequency	Sleep frequency(09-51)~max frequency (00-03)	0.00Hz	↗
09-50	Wake delay time	0s~65000s	0s	↗
09-51	Sleep frequency	0.00Hz~Wake frequency(09-49)	0.00Hz	↗
09-52	Sleep delay time	0s~65000s	0s	↗
09-53	Arrival time setting for this run	0.0Min~6500.0Min	0.0Min	
09-54	Output power correction factor	0.00%~200.0%	100.0%	↗

10 PID Control parameters

↗ indicates that the parameters can be set during operation.

Parameter	Parameter function	Setting range	Factory setting	
10-00	PID given source	0:10-01 setting 1:AVI1 2:AVI2/ACI 3:Reserved 4:PULSE setting(MI5) 5:Communication setting 6:Multi-step speed command given	0	↗
10-01	PID data given	0.0%~100.0%	50.0%	↗

10 PID Control parameters

⚡ indicates that the parameters can be set during operation.

Parameter	Parameter function	Setting range	Factory setting	
10-02	PID feedback source	0:AVI1 1:AVI2/ACI 2:Reserved 3:AVI1-AVI2/ACI 4:PULSE setting(MI5) 5:Communication setting 6:AVI1+AVI2/ACI 7:MAX(AVI1 , AVI2/ACI) 8:MIN(AVI1 , AVI2/ACI)	0	⚡
10-03	PID action direction	0:Positive action 1:Reaction	0	⚡
10-04	PID given feedback range	0~65535	1000	⚡
10-05	Proportional gain Kp1	0.0~999.9	20.0	⚡
10-06	Integration time Ti1	0.00s~10.00s	2.00s	⚡
10-07	Differential time Td1	0.000s~10.000s	0.000s	⚡
10-08	PID reverse cutoff frequency	0.00~Max frequency	0.00Hz	⚡
10-09	PID deviation limit	0.0%~100.0%	0.0%	⚡
10-10	PID differential limiting	0.00%~100.00%	0.50%	⚡
10-11	PID given change time	0.00~650.00s	0.00s	⚡
10-12	PID feedback filter time	0.00~60.00s	0.00s	⚡
10-13	PID output filter time	0.0~600.0s	100.0s	⚡
10-14	Reserved	-	-	⚡
10-15	Proportional gain Kp2	0.0~999.9	20.0	⚡
10-16	Integration time Ti2	0.00s~10.00s	2.00s	⚡
10-17	Differential time Td2	0.000s~10.000s	0.000s	⚡
10-18	PID parameter switching conditions	0:No switch 1:Switch via MI terminal 2:Automatically switch according to deviation 3:Automatically switch according to operating frequency	0	⚡
10-19	PID parameter switching deviation 1	0.0%~10-20	20.0%	⚡
10-20	PID parameter switching deviation 2	10-19~100.0%	80.0%	⚡
10-21	PID Initial value	0.0%~100.0%	0.0%	⚡
10-22	PID initial value hold time	0.00~650.00s	0.00s	⚡
10-23	Reserved			⚡
10-24	Reserved			⚡
10-25	PID feedback upper limit detection	0.0%:No judgment 0.1%~100.0%	0.0%	⚡
10-26	PID feedback lower limit detection	0.0%:No judgment 0.1%~100.0%	0.0%	⚡

10 PID Control parameters

⚡ indicates that the parameters can be set during operation.

Parameter	Parameter function	Setting range	Factory setting	
10-27	PID feedback loss detection time	0.0s~20.0s	0.0s	⚡
10-28	PID shutdown calculation	0:No operation during shutdown 1:Operation at shutdown	0	⚡

11 Fault and protection parameters

⚡ indicates that the parameters can be set during operation.

Parameter	Parameter function	Setting range	Factory setting	
11-00	Motor overload protection selection	0:Disabled 1:Enabled	1	⚡
11-01	Motor overload protection gain	0.20~10.00	1	⚡
11-02	Motor overload pre-warning coefficient	50%~100%	80%	⚡
11-03	Selection of short-circuit protection to ground	Units: short circuit protection on power-on to ground Tens place: short circuit protection to ground before operation 0:Invalid 1:Valid	01	⚡
11-08	Brake initial voltage	350.0~800.0V	220V:370V 380V:690V	⚡
11-09	Fault automatic reset times	0~30	0	⚡
11-10	Action selection of fault multi-function output terminal during fault automatic reset	0:No action 1:Action	0	⚡
11-11	Fault automatic reset interval time	0.1s~100.0s	6.0s	⚡
11-12	Input phase loss protection selection	0:Disabled 1:Output alarm when the running output is 40% of the motor rated current 2:Output alarm when running with phase loss	1	⚡
11-13	Output phase loss protection selection	Bit:output phase loss protection setting 0:Forbid 1~8:Output phase loss check level multiple Tens place: output phase loss protection before running 0:Disabled 1:Enabled	07	⚡
11-14	First failure type	0:No fault 1:Short circuit protection (sc) 2:Overcurrent during acceleration (oc1) 3:Overcurrent during deceleration (oc2) 4:Overcurrent at constant speed (oc3)	—	
11-15	Second failure type	5:Overvoltage during acceleration (ou1) 6:Overvoltage during deceleration (ou2) 7:Overvoltage at constant speed (ou3) 8:Reserved	—	

11 Fault and protection parameters

↗ indicates that the parameters can be set during operation.

Parameter	Parameter function	Setting range	Factory setting	
11-16	Third (last) fault type	9:Undervoltage (UV) 10:Inverter overload (OL2) 11:Motor overload (ORL1) 12:Input phase loss (SPI) 13:Output phase loss (SPO) 14:Module overheat (oh2) 15:External fault (EF) 16:Communication error (CE) 17:Contactor fault (Cotr) 18:Current detection fault (it) 19:Motor auto-tuning fault (TE) 20:Reserved 21:EEPROM read write error (EEP) 22:Inverter hardware fault (EIU) 23:Motor short circuit to ground (SG) 24:Reserved 25:Reserved 26:Running time arrival(Eond) 27:Reserved 28:Reserved 29:Power-on time arrival(EIND) 30:Load failure (oLL) 31:The PID feedback disconnected (EPID) 40:Wave-by-wave current limiting fault (CbC)	—	
11-17	Frequency at the third (latest) failure	—	—	
11-18	Current at the third (latest) fault	—	—	
11-19	Bus voltage at the third (latest) fault	—	—	
11-20	Input terminal status at the third (latest) fault	—	—	
11-21	Output terminal status at the third (latest) fault	—	—	
11-22	Inverter status at the third (latest) fault	—	—	
11-23	Power-on time at the third (latest) fault	—	—	
11-24	Running time at the third (latest) failure	—	—	
11-27	Frequency at second failure	—	—	
11-28	Current at second fault	—	—	
11-29	Bus voltage at the second fault	—	—	
11-30	Input terminal status at the second fault	—	—	
11-31	Output terminal status at the second fault	—	—	
11-32	Inverter status at the second fault	—	—	

11 Fault and protection parameters

⚡ indicates that the parameters can be set during operation.

Parameter	Parameter function	Setting range	Factory setting	
11-33	Power-on time at the second fault	—	—	
11-34	Running time on second failure	—	—	
11-37	Frequency at first failure	—	—	
11-38	Current at first fault	—	—	
11-39	Bus voltage at first fault	—	—	
11-40	Input terminal status at the first fault	—	—	
11-41	Output terminal status at the first fault	—	—	
11-42	Inverter status at first fault	—	—	
11-43	Power-on time at first failure	—	—	
11-44	Operating time at first failure	—	—	
11-47	Fault protection action selection 1	Single digit: Motor overload 0: Coast to stop 1: Stop according to the stop mode 2: Continue to run Tens digital: input phase loss (Same bit) hundreds digital: output phase loss (Same bit) thousands digital: External fault (Same bit) ten thousands digital: Communication error (Same bit)	0	⚡
11-48	Fault protection action selection 2	Single digit: Reserved Tens digital: EEPROM read write fault 0: Coast to stop 1: Stop according to the stop mode hundreds digital: Reserved thousands digital: Reserved ten thousands digital: Operating time arrival (same as 11-47 digits)	0	⚡
11-49	Fault protection action selection 3	Single digit: Reserved Tens digital: Reserved hundreds digital: Power-on time arrival (same as 11-47 digits) thousands digital: Lost load 0: Coast to stop 1: Stop according to the stop mode 2: Decelerate to 7% of the rated frequency of the motor and continue to run. If the load is not lost, it will automatically return to the set frequency. ten thousands digital: PID feedback lost during operation (same as 11-47 digits)	0	⚡
11-50	Fault protection action selection 4	Reserved	0	⚡

11 Fault and protection parameters

↗ indicates that the parameters can be set during operation.

Parameter	Parameter function	Setting range	Factory setting	
11-54	Continue running frequency selection in case of failure	0:Run at current operating frequency 1:Run at set frequency 2:Run at upper limit frequency 3:Run at the lower limit frequency 4:Run at abnormal standby frequency	0	↗
11-55	Abnormal standby frequency	0.0%~100.0%(100.0% corresponds to the maximum frequency 00-03)	100.0%	↗
11-56	Reserved			
11-57	Reserved			
11-58	Reserved			
11-59	Instantaneous power failure action selection	0:Invalid 1:Deceleration 2:Decelerate to stop	0	
11-60	Instantaneous power failure action pause judgment voltage	80~100.0%	85%	
11-61	Judgment time of instantaneous power failure voltage rise	0.0s~100.0s	0.5s	
11-62	Judgment voltage of instantaneous power failure	60%~100%(Standard bus Voltage)	80%	
11-63	Lost load protection options	0:Invalid 1:Valid	0	↗
11-64	Lost load detection level	0.0~100.0%	10.0%	↗
11-65	Lost load detection time	0.0s~60.0s	1.0s	↗
11-66	Load shedding frequency setting	Above this frequency value, 0~102.4% setting load shedding is valid	100.0%	↗
11-67	Reserved			
11-68	Reserved			
11-69	Reserved			
11-70	Reserved			
11-71	Instant stop but non-stop proportional gain	0~100	40	↗
11-72	Instant stop but non-stop integral coefficient	0~100	30	↗
11-73	Action deceleration time of Instant stop but non-stop	0~300.0s	20.0s	
11-74	Level of low-voltage emergency stop	0.0V~6553.5V(0.0 invalid)	0.0V	↗
11-75	OL3 level	0%~100%	100%	↗
11-76	OL3 time	0.00s~650.00s	0.00s	↗
11-79	Reserved			
11-80	Reserved			

12 Serial communication parameters

⚡ indicates that the parameters can be set during operation.

Parameter	Parameter function	Setting range	Factory setting	
12-00	Local address	1~247, 0 is broadcast address	1	⚡
12-01	Baud rate	Single digit: Modbus 0:300bps 1:600bps 2:1200bps 3:2400bps 4:4800bps 5:9600bps 6:19200bps 7:38400bps 8:57600bps 9:115200bps	0005	⚡
12-02	Data format	0:No checking(8-N-1) 1:Even parity checking(8-E-1) 2:Odd parity checking(8-O-1) 3:No checking(8-N-2)	0	⚡
12-03	Communication response delay	0ms~20ms Hundreds digit: 0: have response 1: have response of write 2: no response of read and write	2	⚡
12-04	Communication timeout	0.0(invalid), 0.1s~60.0s	0	⚡
12-05	Reserved			⚡
12-06	Communication reading current resolution	0:0.01A 1:0.1A	0	⚡

13 Wobble frequency counting parameters

⚡ indicates that the parameters can be set during operation.

Parameter	Parameter function	Setting range	Factory setting	
13-00	Wobble setting mode	0:Relative to center frequency 1:Relative to Max frequency	0	⚡
13-01	Wobble amplitude	0.0%~100.0%	0.0%	⚡
13-02	Jump frequency amplitude	0.0%~50.0%	0.0%	⚡
13-03	Wobble frequency cycle	0.1s~3000.0s	10.0s	⚡
13-04	Wobble triangle wave rise time	0.1%~100.0%	50.0%	⚡
13-05	Set length	0m~65535m	0m	⚡
13-06	Actual Length	0m~65535m	0m	⚡
13-07	Pulses per meter	0.1~6553.5	100.0	⚡
13-08	Set count value	1~65535	1000	⚡
13-09	Designated count value	1~65535	1000	⚡

16 Parameter management

↗ indicates that the parameters can be set during operation.

Parameter	Parameter function	Setting range	Factory setting	
16-01	Dedicated macro parameters	0~65535(0 means general model)	0	
16-04	Parameter modification properties	0:Parameters can be read and written 1:The parameter is read-only	0	↗

17 Torque control parameters

↗ indicates that the parameters can be set during operation.

Parameter	Parameter function	Setting range	Factory setting	
17-00	Speed/torque control method selection	0:Speed control 1:Torque control	0	
17-01	Torque setting source selection in torque control mode	0:Digital setting1(17-03) 1:AVI1 2:AVI2/ACI 3:Reserved 4:PULSE 5:Communication setting 6:MIN(AVI1,AVI2/ACI) 7:MAX(AVI1,AVI2/ACI)(1-7 option full scale, corresponding to 17-03 digital setting)	0	
17-03	Torque digital setting in torque control mode	-200.0%~200.0%	150.0%	↗
17-05	Torque control forward maximum frequency	0.00Hz~Max frequency	50.00Hz	↗
17-06	Torque control reverse maximum frequency	0.00Hz~Max frequency	50.00Hz	↗
17-07	Torque control acceleration time	0.00s~65000s	0.00s	↗
17-08	Torque control Deceleration time	0.00s~65000s	0.00s	↗

22 Control optimization parameters

↗ indicates that the parameters can be set during operation.

Parameter	Parameter function	Setting range	Factory setting	
22-00	DPWM switching upper limit frequency	5.00Hz~Maximum operating frequency	8.00Hz	↗
22-01	Modulation	0:Asynchronous modulation 1:Synchronous modulation	0	↗
22-02	Dead zone compensation mode selection	0:No compensation 1:Compensation mode 1	1	↗
22-03	Random PWM depth	0:Random PWM is invalid 1~10:Random depth of PWM carrier frequency	0	↗
22-04	Fast current limit enable	0:No enabling 1:Enabling	1	↗
22-05	Current detection compensation	100~110	105	

22 Control optimization parameters

↗ indicates that the parameters can be set during operation.

Parameter	Parameter function	Setting range	Factory setting	
22-06	Undervoltage level	DC0V-DC420V	220V:200V 380V:350V	↗
22-07	Reserved			
22-08	Reserved			
22-09	Overvoltage level	DC200V-DC820V	220V:400V 380V:820V	

99 Monitoring parameters

↗ indicates that the parameters can be set during operation.

Parameter	Parameter function	Setting range
99-00	Running frequency(Hz)	0.01Hz
99-01	Setting frequency(Hz)	0.01Hz
99-02	Bus voltage(V)	0.1V
99-03	Output voltage(V)	1V
99-04	Output current(A)	0.01A
99-05	Output power(kW)	0.1kW
99-06	Output torque(%)	0.1%
99-07	MI input status	1
99-08	MO output status	1
99-09	AVI1 voltage(V)	0.01V
99-10	AVI2/ACI voltage(V)	0.01V
99-11	Reserved	
99-12	Count value	1
99-13	Length	1
99-14	Load speed	1
99-15	PID setting	1
99-16	PID feedback	1
99-17	PLC stage	1
99-18	PULSE input pulse frequency(Hz)	0.01kHz
99-19	Feedback speed(Unit 0.1Hz)	0.1Hz
99-20	Remaining running time	0.1Min
99-21	AVI1 voltage before calibration	0.001V
99-22	AVI2/ACI voltage before calibration	0.001V
99-23	Counter 2 low position	
99-24	Counter 2 high position	1(99-23 is 1 too)
99-25	Current power-on time	1Min
99-26	Current running time	0.1Min
99-27	PULSE input pulse frequency	1Hz

99 Monitoring parameters

✎ indicates that the parameters can be set during operation.

Parameter	Parameter function	Setting range
99-28	Communication setting value	0.01%
99-29	Reserved	
99-30	Main frequency X display	0.01Hz
99-31	Auxiliary frequency Y display	0.01Hz
99-32	View any memory address value	1
99-33	Reserved	
99-34	Reserved	
99-35	Target torque (%)	0.1%
99-36	Reserved	
99-37	Reserved	
99-38	Reserved	
99-39	V/f separation target voltage	1V
99-40	V/f separation output voltage	1V
99-41	Visual display of MI input status	1
99-42	Visual display of MO input status	1
99-43	MI function status visual display 1(function 01- function 40)	1
99-44	MI function status visual display 2(function 41- function 50)	1
99-59	Setting frequency (%)	0.01%
99-60	Running frequency (%)	0.01%
99-61	Inverter status	1

Remark: parameter of the confirmed model

Parameter	Parameter function	Parameter value
00-07	Acceleration time 1	45kW and below: 10.0s 55kW and below: 50.0s
00-08	Deceleration time 1	Some to the above
09-03 09-04 09-05 09-06 09-07 09-08	Acceleration and deceleration time 2,3,4	Some to the above
00-10	Carrier frequency	30kW and below: 6.0k 45kW and below: 5.0k 55kW and below: 4.0k 630kW and below: 3.0k
03-01	Torque boost	Motor power ≤ 1.0kW: 6.0% Motor power ≤ 4.0kW: 4.0% Motor power ≤ 7.5kW: 3.0% Motor power ≤ 37.0kW: 2.0% Other: 1.0%

5 DESCRIPTION OF FUNCTIONAL PARAMETERS

This chapter will give a detailed description of all functional parameters. It is divided into various parameter groups according to the attributes of the parameters; making parameter setting easier. In most applications, users can complete the settings before operation according to the related parameter settings in the parameter group.

The parameter groups are as follows

Parameter	Function	Parameter	Function	Parameter	Function
00	Basic function parameters	06	Output terminal parameters	12	Serial communication parameters
01	Motor control parameters	07	Start and stop control parameters	13	Wobble frequency counting parameters
02	Vector control parameters	08	Man-machine interface parameters	17	Torque control parameters
03	V/f control parameters	09	Accessibility parameters	22	Control optimization parameters
04	Input terminal parameters	10	PID control parameters	99	Monitoring parameters
05	Multi-speed, simple PLC control	11	Fault and protection parameters		

↗ Indicates that the parameters can be set during operation

00 Basic Functions Parameters

00-00	Command source selection		↗	Factory setting	0
	Setting range	0	Keyboard command (LED off)		
		1	Terminal command (LED on)		
		2	Communication command (LED flicker)		

Select the input channel for inverter control commands.

Inverter control commands include: start, stop, forward, reverse, and jog.

0: Keyboard command channel ("LOC/REM" indicator off)

Run command control is performed by the RUN, STOP/RESET buttons on the operation panel.

1: Terminal command channel ("LOC/REM" indicator on)

Run command control is performed by multi-function input terminals FWD, REV, FJOG, RJOG, etc.

2: Communication command channel ("LOC/REM" indicator flicker)

The running command is given by the host computer through communication.

00-01	Keyboard and terminal UP/DOWN setting selection		↗	Factory setting	2
	Setting range	0	Stop memory and power failure storage		
		1	Stop memory		
		2	Stop no memory		

This function is only valid when the frequency source is set digitally.

"Stop memory" refers to the inverter is stopped, a digital frequency keep the last set frequency retention time, keyboard ▲, ▼ key or the UP terminal, the frequency correction for maintaining effective DOWN, and again after power down Still effective.

"Stop memory" means that after the inverter is stopped, the digital set frequency is retained as the set frequency at the last stop time, and the frequency correction by the keyboard ▲, ▼ keys or terminals UP and DOWN remains valid.

"Stop no memory" means that after the inverter stops, the digital set frequency value returns to the value of 00-06 (keyboard given frequency), and the frequency correction performed by the keyboard ▲, ▼ keys or terminals UP and DOWN is cleared.

00-02	Main frequency source X selection	Factory setting	1
Setting range	0	Digital setting (keyboard given frequency 00-06, UP/DOWN can be modified)	
	1	AVI1	
	2	AVI2/ACI	
	3	Reserved	
	4	Multi-speed command	
	5	PID control	
	6	Communication setting	
	7	Simple PLC	
	8	Panel potentiometer	
	9	Pulse setting (MI5)	

Select the input channel of the main given frequency of the inverter:

0: Digital setting

The initial value of the set frequency is 00-06 "Keyboard given frequency" value. The set frequency value of the inverter can be changed by the ▲ and ▼ keys of the keyboard (or UP and DOWN of the multi-function input terminal).

Tip: Please refer to parameter 00-01 for UP and DOWN.

1: AVI1

2: AVI2/ACI

3: Reserved

The frequency is determined by the analog input terminal. The control board provides 2 analog input terminals (AVI1, AVI2/ACI).

Among them, AVI1 is 0V ~ 10V voltage type input, AVI2/ACI can be 0V ~ 10V voltage input, can also be 4mA ~ 20mA current input, selected by the jumper on the control board.

The corresponding relationship between the input voltage value of AVI1, AVI2/ACI and the target frequency can be freely selected by the user.

4: Multi-speed command

When this frequency setting mode is selected, the inverter runs in multi-speed mode. Group 04 and Group 05 "multi-stage speed control group" parameters need to be set to determine the correspondence between a given percentage and a given frequency, the multi-step speed command will take precedence over other frequency reference methods.

5: PID

If this parameter is selected, the inverter operation mode is process PID control. At this time, 10 groups of "PID control groups" need to be set. The running frequency of the inverter is the frequency value after PID function. For the meaning of PID given source, given amount and feedback source, please refer to the introduction of 10 groups of "PID function".

6: Communication setting

The frequency command is given by the host computer through communication. For details, please refer to 12 Communication protocol.

7: Simple PLC

When the frequency source is a simple PLC, the operating frequency source of the inverter can be switched between 1 to 16 arbitrary frequency commands. The holding time of 1 to 16 frequency commands and the respective acceleration and deceleration time can also be set by the user. 05 group related instructions.

8: Panel potentiometer

The main frequency source is given by the rotation of the potentiometer on the panel.

9: Pulse setting (MI5)

Frequency setting is given by terminal pulse (pulse can only be input from input terminal MI5). Pulse given signal specifications: voltage range 20V ~ 27V, frequency range 0kHz ~ 100kHz.

The pulse frequency of the MI5 terminal input is set with reference to 04-28~04-31. The pulse input is set to 100.0%, relative to the percentage of the maximum frequency 00-03.

00-03	Maximum frequency		Factory setting	50.00 Hz
	Setting range	50.00Hz~500.00Hz		

Used to set the maximum output frequency of the inverter. Frequency commands are all scaled according to this parameter, which is the basis of frequency setting.

The maximum output frequency of S3100A can reach 3200Hz. The frequency command resolution and frequency input range can be changed by selecting the number of decimal places of frequency command through 00-25.

When 00-25 is 1, the frequency resolution is 0.1Hz, and the setting range of 00-03 is 50.0Hz~3200.0Hz;

00-04	Upper limit frequency	↗	Factory setting	50.00Hz
	Setting range	Lower limit frequency 00-05~max frequency 00-03		

When the upper limit frequency is set by analog or PULSE, 00-21 is used as the offset value of the set value, and the offset frequency is 00-20.

The set upper limit frequency value is superimposed as the final upper limit frequency setting value.

00-05	Lower limit frequency	↗	Factory setting	0.00Hz
	Setting range	0.00Hz~Upper limit frequency 00-04		

When the frequency command is lower than the lower limit frequency set by 00-05, the inverter can be stopped, run at the lower limit frequency or run at zero speed, and set the operation mode through 09-14 (the set frequency is lower than the lower limit frequency operation mode).

00-06	Keyboard setting frequency	↗	Factory setting	50.00Hz
	Setting range	0.00~max frequency 00-03		

When the frequency source is selected as "digital setting", the parameter value is the initial value of the frequency digital setting of the inverter.

00-07	Acceleration time1	↗	Factory setting	Type setting
	Setting range	0.00s~65000s		
00-08	Deceleration time 1	↗	Factory setting	Type setting
	Setting range	0.00s~65000s		

The acceleration time refers to the time required for the inverter to accelerate from zero frequency to the acceleration and deceleration base frequency (determined from 00-23), see t1 in Figure 5-1.

The deceleration time refers to the time required for the inverter to decelerate to the zero frequency from the base frequency of acceleration and deceleration (determined from 00-23), see t2 in Figure 5-1

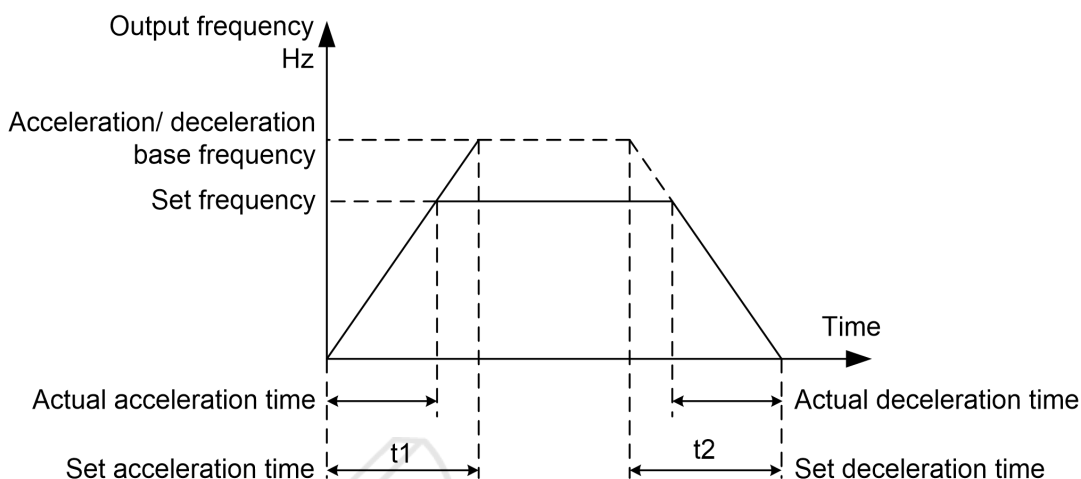

Figure 5-1 Schematic diagram of acceleration and deceleration time

S3100A provides 4 groups of acceleration and deceleration time, users can use the digital input terminal MI to switch selection, the four groups of acceleration and deceleration time are set by the following parameters:

The first group: 00-07, 00-08; The second group: 09-03, 09-04; The third group: 09-05, 09-06; The fourth group: 09-07, 09-08.

00-09	Operation direction		↗	Factory setting	0
	Setting range	0	Forward		
		1	Reverse		

Used to change the direction of the motor, its role is equivalent to changing the direction of motor rotation by adjusting any two motor lines.

Note: After the parameters are initialized, the motor running direction will return to its original state. For occasions where it is strictly forbidden to change the direction of the motor after system debugging, please use it with caution.

00-10	Carrier frequency		↗	Factory setting	Type setting
	Setting range	0.5kHz~16.0kHz			

This function adjusts the carrier frequency of the inverter. By adjusting the carrier frequency can reduce the motor noise, avoid the resonance point of the mechanical system, reduce the line leakage current to the ground and reduce the interference generated by the inverter.

The advantages of high carrier frequency: the current waveform is ideal, the current harmonics are less, and the motor noise is small;

Disadvantages of high carrier frequency: increased switching loss, increased temperature rise of the inverter, and affected the output capacity of the inverter. Under high carrier frequency, the inverter needs to be derated; at the same time, the leakage current of the inverter increases, which Increased electromagnetic interference.

The effect of carrier frequency on the following performance:

Carrier frequency	Low	→	High
Motor noise	Large	→	Small
Output current waveform	Bad	→	Good
Motor temperature rise	High	→	Low
Inverter temperature rise	Low	→	High

Leakage current	Small → Large
External radiation interference	Small → Large

The factory setting of carrier frequency is different according to different power models. The user can modify it as needed, but it should be noted that if the carrier frequency is set higher than the factory value, it will cause the temperature rise of the inverter radiator to increase. At this time, the user needs to derate the inverter, otherwise the inverter will be in danger of overheating.

00-11	Parameter initialization		Factory setting	0
	Setting range	0	No operation	
		1	Restore factory parameters, excluding motor parameters	
		2	Clear record information	

1. Restore the factory settings, most of the inverter parameters are restored to the factory values, but the motor parameters, frequency command decimal point (00-25), fault record information, cumulative running time (08-11), cumulative power-on time (08-13), the cumulative power consumption (08-14) does not recover.

2. Clear record information

Clear the inverter fault record information, cumulative running time (08-11), cumulative power-on time (08-13), cumulative power consumption (08-14).

Note: The parameter value automatically returns to 0 after the operation is completed.

00-12	Carrier frequency adjustment		↗	Factory setting	1
	Setting range	0	No automatic carrier reduction		
		1	Automatic carrier reduction		
		2	Low noise		

The carrier frequency is adjusted with the temperature. When the inverter detects that the radiator temperature is high, the carrier frequency is automatically reduced to prevent the inverter temperature from rising too high and reduce the overheating alarm. When the temperature of the radiator drops, the carrier frequency automatically returns to the set value.

00-14	Auxiliary frequency source Y selection (Refer to 00-02)		Factory setting	0
	Setting range	0	Digital setting (keyboard given frequency 00-06, UP /DOWN can be modified)	
		1	AVI1	
		2	AVI2/ACI	
		3	Reserved	
		4	Multi-speed command	
		5	PID control	
		6	Communication setting	
		7	Simple PLC	
		8	Panel potentiometer	
		9	Pulse setting (MI5)	

When the auxiliary frequency source is used independently as the frequency reference channel (that is, the frequency source selection is switched to Y), the method of use is the same as the main frequency source X. You can refer to the 00-02 instructions.

When the auxiliary frequency source is given as a superposition (that is, the frequency source is selected as X+Y, X to X+Y switching or Y to X+Y switching), please note:

(1) When the auxiliary frequency source selects the digital setting, the given frequency (00-06) of the keyboard does not work, and the frequency can be adjusted by the ▲ and ▼ keys of the keyboard (or UP and DOWN of the multi-function input terminal). The frequency is adjusted on the basis of the main frequency.

(2) When the auxiliary frequency source selects analog (AVI1, AVI2/ACI) or pulse input as the timing, the input setting 100% corresponds to the frequency range, which can be set by 00-15 and 00-16.

Note: The setting values of 00-02 and 00-14 cannot be the same, that is, the auxiliary frequency source Y and the main frequency source X cannot select the same channel, otherwise the operation may be messy.

00-15	Selection of auxiliary frequency source Y range during stacking		↗	Factory setting	0
	Setting range	0	Relative to the maximum frequency		
		1	Relative to the main frequency source X		

00-16	Auxiliary frequency source Y range when superimposed		↗	Factory setting	100%
	Setting range	0%~150%			

When the frequency source is selected as "frequency superposition" (that is, 00-17 is set to 1, 3 or 4), these two parameters are used to determine the adjustment range of the auxiliary frequency source.

00-15 if you select 1 relative to the main frequency source X, the range of the auxiliary frequency source will change with the change of the main frequency X.

00-17	Frequency source overlay selection		↗	Factory setting	0
	Setting range	Single digit	Frequency source selection		
		0	Main frequency source X		
		1	Main and auxiliary calculation results (the operation relationship is determined by ten digits)		
		2	Switch between main frequency source X and auxiliary frequency source Y		
		3	Switch between main frequency source X and main and auxiliary calculation results		
		4	Switch between auxiliary frequency source Y and main and auxiliary calculation results		
		Tens digit	Frequency source main and auxiliary operation relationship		
		0	Main+auxiliary		
		1	Main-auxiliary		
		2	Maximum of both		
		3	Minimum of both		

Use this parameter to select the frequency reference channel. The frequency setting is realized by the combination of the main frequency source X and the auxiliary frequency source Y.

Single digit: frequency source selection:

0: Main frequency source X

The main frequency X is taken as the target frequency.

1: Main and auxiliary calculation results: The main and auxiliary calculation results are used as the target frequency. For the relationship between the main and auxiliary calculations, please refer to the description of "Ten" of this parameter.

2: Switch between main frequency source X and auxiliary frequency source Y: When multi-function input terminal function 18 (frequency switching) is invalid, main frequency X is used as the target frequency.

When the multi-function input terminal function 18 (frequency source switching) is valid, the auxiliary frequency Y is used as the target frequency.

3: Switch between main frequency source X and main and auxiliary calculation results: When multi-function input terminal function 18 (frequency switching) is invalid, main frequency X is used as the target frequency. When the multi-function input terminal function 18 (frequency switching) is valid, the main and auxiliary calculation results are used as the target frequency.

4: Switch between auxiliary frequency source Y and main and auxiliary calculation results: When multi-function input terminal function 18 (frequency switching) is invalid, auxiliary frequency Y is used as the target frequency. When the multi-function input terminal function 18 (frequency switching) is valid, the main and auxiliary calculation results are used as the target frequency.

Tens: Main and auxiliary calculation relationship of frequency source:

0: Main frequency source X + auxiliary frequency source Y

The sum of the main frequency X and the auxiliary frequency Y is taken as the target frequency. Realize the given function of frequency superposition.

1: Main frequency source X - auxiliary frequency source Y

The difference between the main frequency X and the auxiliary frequency Y is taken as the target frequency.

2: MAX (main frequency source X, auxiliary frequency source Y): Take the maximum absolute value of the main frequency X and auxiliary frequency Y as the target frequency.

3: MIN (main frequency source X, auxiliary frequency source Y): Take the minimum absolute value of the main frequency X and auxiliary frequency Y as the target frequency. In addition, when the frequency source is selected as the main and auxiliary operations, the offset frequency can be set through 00-19, and the offset frequency is superimposed on the main and auxiliary operation results to flexibly respond to various needs.

00-19	Auxiliary frequency source offset frequency when superimposed	↗	Factory setting	0.00Hz
	Setting range	0.00Hz~max frequency 00-03		

This parameter is only valid when the frequency source is selected as the main and auxiliary operation.

When the frequency source is the main and auxiliary operation, 00-19 is used as the offset frequency, and the result of the main and auxiliary operation is superimposed as the final frequency setting value, and the frequency setting is more flexible.

00-20	Upper frequency source	Factory setting	0
	Setting range	0	00-04 setting
		1	AVI1
		2	AVI2/ACI
		3	Reserved
		4	Pulse setting
		5	Communication setting

Source selection for upper frequency. Especially in torque control, the output frequency of the inverter can be changed by changing the upper limit frequency.

Note: 100% of the analog input setting corresponds to 00-04.

00-21	Upper frequency offset	↗	Factory setting	0.00Hz
	Setting range	0.00Hz~max frequency 00-03		

When the upper limit frequency is set by analog or PULSE, 00-21 is used as the offset value of the set value, and the offset frequency is superimposed on the set upper limit frequency value of 00-20 as the final set value of the upper limit frequency.

00-22	Acceleration and deceleration time unit	Factory setting	1
	Setting range	0	1s
		1	0.1s
		2	0.01s

S3100A has 3 kinds of acceleration and deceleration time unit selection. When modified, the decimal points of the 4 groups of acceleration and deceleration time will change, and the corresponding acceleration and deceleration time will also change. In application, pay attention to the specific value of acceleration and deceleration time.

00-23	Base frequency of acceleration and deceleration time	Factory setting	0
	Setting range	0	Maximum frequency (00-03)
		1	Set frequency
		2	100Hz

The acceleration and deceleration time refers to the acceleration and deceleration time from zero frequency to the frequency set by 00-23. Figure 5-1 is the schematic diagram of acceleration and deceleration time.

When 00-23 is selected as 1, if the set frequency changes frequently, the acceleration of the motor will also follow the change, so you need to pay attention to it during application.

00-24	Base frequency for UP/DOWN command during running	Factory setting	1
	Setting range	0	Running frequency
		1	Set frequency
		2	When stop, the frequency can not be changed
		3	When stop, up down cleared

This parameter is valid only when the frequency source is digitally set.

When the ▲, ▼ keys on the keyboard or the terminal UP/DOWN change the frequency, select whether to increase or decrease based on the running frequency or increase or decrease based on the set frequency.

Note that when 0 is selected, when the inverter is increasing or decreasing when the inverter is in the process of acceleration and deceleration, the given frequency may change significantly.

00-25	Frequency command resolution	Factory setting	2
	Setting range	1	0.1Hz
		2	0.01Hz

This parameter is used to determine the number of decimal points for all frequencies, and the frequency resolution also changes accordingly.

When the frequency resolution is 0.1Hz, the maximum output frequency of S3100A can reach 3200.0Hz.

01 Motor Control Parameters

01-00	The first motor control mode		Factory setting	0
	Setting range	0	Speed sensorless vector control (SVC)	
		2	Vf control	

0: Speed sensorless vector control

Refers to open-loop vector control, which is suitable for the usual high-performance control occasions. One inverter can only drive one motor. Such as machine tools, centrifuges, wire drawing machines, injection molding machines and other loads.

2: V/f control Applicable to the occasions where the load requirement is not high, or one inverter drives multiple motors, such as fans and pumps. It can be used in a situation where one inverter drives multiple motors.

Tip: Motor vector parameter self-learning must be done when selecting vector control mode. Only accurate motor parameters can take advantage of the vector control method. By adjusting the speed regulator parameter 02 group of parameters, you can get better performance.

01-01	Motor parameter self-learning		Factory setting	0
	Setting range	0	No self-learning	
		1	Asynchronous motor static self-learning	
		2	Asynchronous motor complete self-learning	

0: No self-learning.

1: Asynchronous motor static self-learning, suitable for occasions where asynchronous motor and load are not easy to disconnect. Before static self-learning, the motor nameplate parameters 01-02~01-06 must be set correctly. Asynchronous motor static self-learning, the inverter can obtain three parameters 01-07~01-09.

Action description: Set the function code to 1, and then press the RUN key, the inverter will perform static self-learning.

2: Asynchronous motor complete self-learning

In order to ensure the dynamic control performance of the inverter, please select complete self-learning. At this time, the motor must be disconnected from the load to keep the motor in a no-load state.

In the complete self-learning process, the inverter first performs static self-learning, and then accelerates to the rated frequency of the motor according to the acceleration time 00-07 80%, after a period of time, decelerate to stop according to the deceleration time 00-08 and end self-learning.

Before the complete self-learning of the asynchronous motor, in addition to the need to set the motor type and motor nameplate parameters 01-02~01-06, after self-learning, the inverter can obtain five motor parameters 01-07~01-11, vector control PI parameters 02-13~02-16.

Action description: Set the function code to 2, and then press the RUN key, the inverter will perform complete self-learning.

01-02	Motor rated power		Factory setting	Type setting
	Setting range	0.1kW~1000.0kW		
01-03	Motor rated frequency		Factory setting	Type setting
	Setting range	0.01Hz~max frequency		
01-04	Motor rated rotation speed		Factory setting	Type setting
	Setting range	1rpm~65535rpm		

01-05	Motor rated voltage	Factory setting	Type setting
	Setting range	1V~2000V	
01-06	Motor rated current	Factory setting	Type setting
	Setting range	0.01A~655.35A(Inverter power <=55kW) 0.1A~6553.5A(Inverter power >55kW)	

Note: The above are the motor nameplate parameters, regardless of V/f control or vector control, the relevant parameters need to be set accurately according to the motor nameplate.

In order to obtain better V/f or vector control performance, motor parameter self-learning is required. Accurate parameter self-learning comes from the correct input of motor nameplate parameters.

01-07	Asynchronous motor stator resistance	Factory setting	Type setting
	Setting range	0.001Ω~65.535Ω (Inverter power <=55kW) 0.0001Ω~6.5535Ω (Inverter power >55kW)	
01-08	Rotor resistance of asynchronous motor	Factory setting	Type setting
	Setting range	0.001Ω~65.535Ω (Inverter power <=55kW) 0.0001Ω~6.5535Ω (Inverter power >55kW)	
01-09	Asynchronous motor leakage inductance	Factory setting	Type setting
	Setting range	0.01mH~655.35mH (Inverter power <=55kW) 0.001mH~65.535mH (Inverter power >55kW)	
01-10	Asynchronous motor mutual inductance	Factory setting	Type setting
	Setting range	0.1mH~6553.5mH (Inverter power <=55kW) 0.01mH~655.35mH (Inverter power >55kW)	
01-11	Asynchronous motor no-load current	Factory setting	Type setting
	Setting range	0.01A~01-06(Inverter power <=55kW) 0.1A~01-06(Inverter power >55kW)	

After the motor parameter self-learning ends normally, the setting value of 01-07 ~ 01-11 will be updated automatically. These parameters are the benchmark parameters of high-performance vector control and have a direct impact on the performance of the control.

Note: Users should not change this group of parameters at will.

01-12	Motor type selection	Factory setting	0
	Setting range	0	Ordinary asynchronous motor
		1	Frequency conversion asynchronous motor

02 Vector Control Parameters

02 Group parameters are only valid for vector control, not for V/f control.

02-00	Speed loop proportional gain 1	↗	Factory setting	30
	Setting range	1~100		
02-01	Speed loop integration time 1	↗	Factory setting	0.50s
	Setting range	0.01s~10.00s		
02-02	Switching frequency 1	↗	Factory setting	5.00Hz
	Setting range	0.00~02-05		
02-03	Speed loop proportional gain 2	↗	Factory setting	20
	Setting range	0~100		
02-04	Speed loop integration time 2	↗	Factory setting	1.00s
	Setting range	0.01s~10.00s		
02-05	Switching frequency 2	↗	Factory setting	10.00Hz
	Setting range	02-02~max frequency		

When the inverter runs at different frequencies, you can select different speed loop PI parameters. Below the switching frequency 1 (02-02), the speed loop PI parameters are: 02-00 and 02-01. Above the switching frequency 2 (02-05), the speed loop PI parameters are: 02-03 and 02-04. Between the two, the PI parameters are obtained from the linear changes of the two sets of parameters, as shown in Figure 5-2:

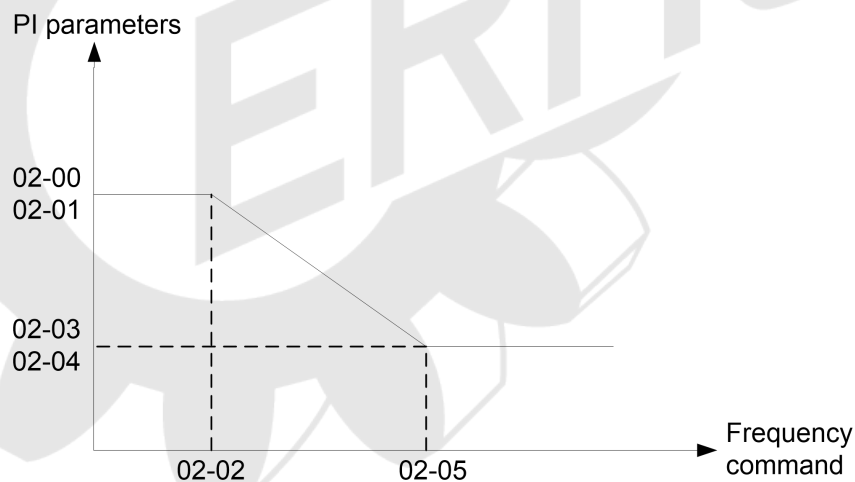

Figure 5-2 Schematic diagram of PI parameter

By setting the proportional coefficient and integral time of the speed regulator, the dynamic response characteristics of the speed loop of vector control can be adjusted. Increasing the proportional gain and reducing the integration time can speed up the dynamic response of the speed loop. However, if the proportional gain is too large or the integration time is too small, it is easy to cause system oscillation and overshoot. If the proportional gain is too small, it may easily lead to steady-state oscillation of the system, and there may be a static speed difference.

The PI parameters of the speed loop are closely related to the inertia of the system. For different load characteristics, the default PI parameters need to be adjusted to meet the needs of various occasions.

02-06	Vector control slip gain	↗	Factory setting	100%
	Setting range	50%~200%		

For speed sensorless vector control, this parameter is used to adjust the speed stability accuracy of the motor: when the motor is loaded with a low speed, increase this parameter, and vice versa.

02-07	Digital setting of torque upper limit in speed control mode	↗	Factory setting	150.0%
	Setting range	0.0%~200.0%		

In speed control mode, the maximum value of the inverter's output torque is selected by the upper torque source 02-10. When the analog, PULSE pulse, and communication settings are selected, the corresponding set 100% corresponds to 02-07, 100% is the rated torque of the inverter.

02-08	Speed loop filter time constant	↗	Factory setting	0.015s
	Setting range	0.000s~0.100s		

In vector control mode, this parameter is used to filter the speed loop torque command. This parameter generally does not need to be adjusted. When the speed fluctuation is large, the filtering time can be increased appropriately; if the motor oscillates, the parameter should be appropriately reduced. The speed loop filter time constant is small, the output torque of the inverter may fluctuate greatly, but the speed response is fast.

02-09	Vector control over excitation gain	↗	Factory setting	64
	Setting range	0~200		

During deceleration of the inverter, overexcitation control can suppress the rise of bus voltage and avoid overvoltage faults. The greater the overexcitation gain, the stronger the suppression effect.

However, if the gain is too large, it is easy to cause the output current to increase, which needs to be set appropriately. For the occasions with small inertia and braking resistance, it is recommended to set the gain to 0.

02-10	Torque upper limit source in speed control mode	↗	Factory setting	0
	Setting range	0	Parameter setting	
		1	AVI1	
		2	AVI2/ACI	
		3	reserved	
		4	Pulse setting	
		5	Communication setting	
		6	MIN(AVI1,AVI2/ACI)	
		7	MAX(AVI1,AVI2/ACI)	
	The full scale of the 1-7 option corresponds to 02-07			

In speed control mode, this parameter is used to select the torque upper limit source of the inverter.

02-13	Excitation adjustment proportional gain	↗	Factory setting	2000
	Setting range	0~60000		
02-14	Excitation adjustment integral gain	↗	Factory setting	1300
	Setting range	0~60000		
02-15	Torque adjustment proportional gain	↗	Factory setting	2000
	Setting range	0~60000		
02-16	Torque adjustment integral gain	↗	Factory setting	1300
	Setting range	0~60000		

The vector control PI adjusts the parameter. This parameter is automatically obtained after the asynchronous motor completes self-learning, and generally does not need to be modified.

03 V/f Control Parameters

Group 03 parameters are only valid for V/f control, not for vector control.

03-00	V/f curve setting	Factory setting	0
Setting range	0	Straight line V/f	
	1	Multi-point V/f	
	2	Square V/f	
	3	1.2 power V/f	
	4	1.4 power V/f	
	6	1.6 power V/f	
	8	1.8 power V/f	
	9	reserved	
	10	V/f complete separation mode	
	11	V/f half separation mode	

0: Straight line V/f. Suitable for ordinary constant torque loads.

1: Multi-point V/f. Suitable for special loads such as dehydrator and centrifuge. By setting 03-03~03-08 parameters, you can get any V/f curve.

2: Square V/f. Suitable for centrifugal loads such as fans and pumps.

3~8: V/f relationship curve between straight line V/f and 2.0th order V/f.

10: V/f complete separation mode. At this time, the output frequency of the inverter is independent of the output voltage. The output frequency is determined by the frequency source, and the output voltage is determined by 03-13 (V/f separated voltage source).

This mode is generally used in induction heating, inverter power supply, torque motor control and other occasions.

11: V/f half separation mode. In this mode, V and F are proportional, but the proportional relationship can be set by voltage source 03-13, and the relationship between V and F is also related to the rated voltage and rated frequency of motor group 01.

Assuming that the voltage source input is X (X is a value of 0~100%), the relationship between the output voltage V of the inverter and the frequency F is: $V/f=2 * X * (\text{motor rated voltage})/(\text{motor rated frequency})$

03-01	Torque boost	↗	Factory setting	Type setting
	Setting range	0.0%:(auto-torque boost) 0.1%~30.0%		
03-02	Cut-off frequency of torque boost	Factory setting	50.00Hz	
	Setting range	0.00Hz~max frequency		

Torque boosting can improve the low-frequency torque characteristics of V/f and do boost compensation for the output voltage. However, if the torque boost setting is too large, the motor is easily overheated and the inverter is easily overcurrent.

When the torque boost is set to 0.0, the inverter is in automatic torque boost, and the inverter automatically calculates the torque boost value according to the motor stator resistance and other parameters.

Torque boost torque cut-off frequency: Below this frequency, the torque boost is valid, and beyond this set frequency, the torque boost is invalid, as shown in Figure 5-3.

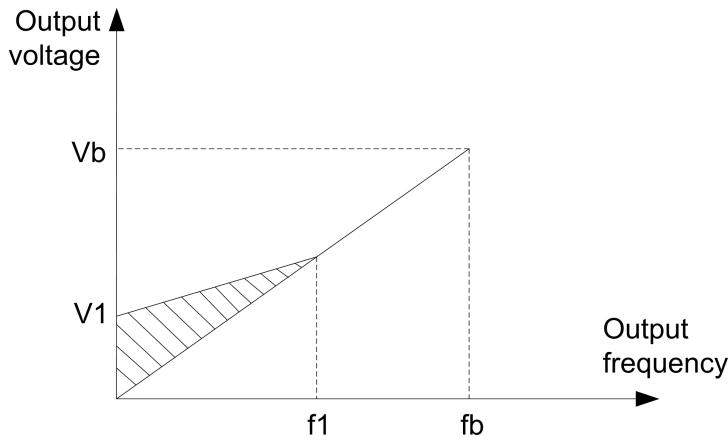

V1: Manual torque boost voltage
 Vb: Maximum output voltage
 f1: Cut-off frequency of manual torque boost
 fb: Rated running frequency

Figure 5-3 Schematic diagram of manual torque boost

03-03	Multi-point V/f frequency point 1	Factory setting	0.00Hz
	Setting range	0.00Hz~03-05	
03-04	Multi-point V/f voltage point 1	Factory setting	0.0%
	Setting range	0.0%~100.0%	
03-05	Multi-point V/f frequency point 2	Factory setting	0.00Hz
	Setting range	03-03~03-07	
03-06	Multi-point V/f voltage point 2	Factory setting	0.0%
	Setting range	0.0%~100.0%	
03-07	Multi-point V/f frequency point 3	Factory setting	0.00Hz
	Setting range	03-05~motor rated frequency(01-03)	
03-08	Multi-point V/f voltage point 3	Factory setting	0.0%
	Setting range	0.0%~100.0%	

Parameters 03-03~03-08 can define multi-segment V/f curve.

The curve of the multi-point V/f should be set according to the load characteristics of the motor. Note that the relationship between the three voltage points and the frequency point must meet: $V1 < V2 < V3$, $F1 < F2 < F3$. Figure 5-4 is a schematic diagram of multi-point V/f curve setting.

If the voltage is set too high at low frequency, the motor may overheat or even burn, and the inverter may be overcurrent stalled or overcurrent protected.

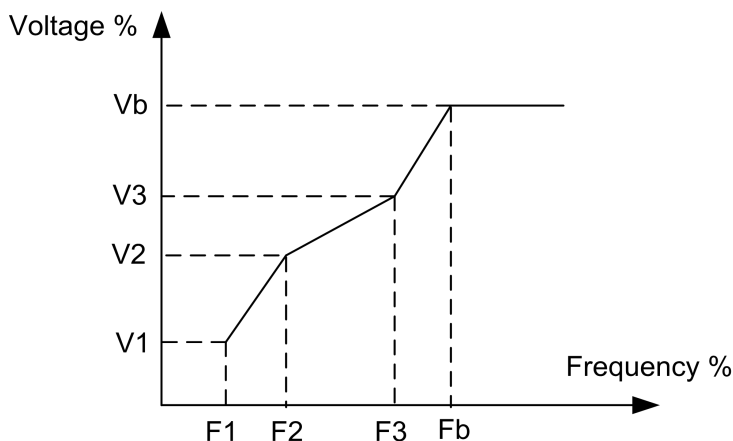

V1-V3: Voltage percentage of the 1st-3rd segment of multi-point V/f
 F1-F3: Frequency percentage of the 1st-3rd segment of multi-point V/f
 Vb: Rated voltage of motor
 Fb: Rated running frequency of motor

Figure 5-4 Schematic diagram of multi-point V/f curve setting

03-09	V/f slip compensation gain	↗	Factory setting	0.0%
	Setting range	0.0%~200.0%		

V/f slip compensation can compensate the motor rotation deviation generated by the asynchronous motor when the load increases, so that the motor speed can be basically stabilized when the load changes.

03-10	V/f overexcitation gain	↗	Factory setting	64
	Setting range	0~200		

During the deceleration of the inverter, the overexcitation control can suppress the rise of the bus voltage and avoid overvoltage faults. The greater the gain, the stronger the suppression effect. However, if the overexcitation gain is too large, the output current is likely to increase, and a moderate setting is required. For applications where the inertia is small or the braking resistor is used, the recommended gain is set to zero.

03-11	V/f oscillation suppression gain	↗	Factory setting	Type setting
	Setting range	0~100		

The selection method of the gain is as small as possible under the premise of effectively suppressing the oscillation, so as to avoid adversely affecting the V/f operation. Select this gain to be 0 when there is no oscillation in the motor. It is only necessary to increase the gain appropriately when the motor oscillates significantly. The greater the gain, the more obvious the suppression of the oscillation.

When using the suppression oscillation function, the motor rated current and no-load current parameters are required to be accurate, otherwise the V/f oscillation suppression effect is not good.

03-13	V/f separated voltage source	↗	Factory setting	0
	Setting range	0	Digital setting(03-14)	
		1	AVI1	
		2	AVI2/ACI	
		3	Reserved	
		4	PULSE setting (MI5)	
		5	Multi-step speed command	
		6	Simple PLC	
		7	PID	
		8	Communication setting	
		Note: 100.0% corresponds to the rated voltage of the motor		

03-14	Voltage digital setting of V/f detached	↗	Factory setting	0V
	Setting range	0V~Motor rated voltage		

V/f detach separation is generally used in applications such as induction heating, inverter power supply and torque motor control.

If V/f separated control is selected, the output voltage can be set by parameter 03-14, or set communication can be given by analog quantity, multi-step speed command, PLC, PID or communication. When a non-numeric setting is selected, 100% of each setting corresponds to the rated voltage of the motor. When the percentage of the output setting such as the analog quantity is negative, the set absolute value is used as the effective setting value.

0.Digital setting (03-14)

Voltage is set by 03-14.

1.AVI1

2.AVI2/ACI

Voltage is confirmed by analog input terminal.

4.Pulse setting(MI5)

The voltage reference is given by the terminal pulse. Pulse given signal specifications: voltage range 20V ~ 27V, frequency range 0kHz ~ 100kHz.

5.Multi-step speed command

When the voltage source is a multi-speed command, set the 04 group and 05 group parameters to select the correspondence between the given signal and the given voltage.

6. Simple PLC

When the voltage source is a simple PLC, you need to set 05 group of parameters to determine the given output voltage.

7.PID

The output voltage is generated according to the PID closed loop. For details, see 10 group of PID introduction.

8.Communication setting

The voltage is given by the host computer through communication.

When the above voltage source is selected from 1 to 8, 0 to 100% corresponds to the output voltage 0V to the rated voltage of the motor.

03-15	V/f separated voltage rise time	↗	Factory setting	0.0s
	Setting range	0.0s~1000.0s		

The V/f detach rise time refers to the time required for the output voltage to change from 0V to the rated voltage of the motor. As shown in figure 5-5:

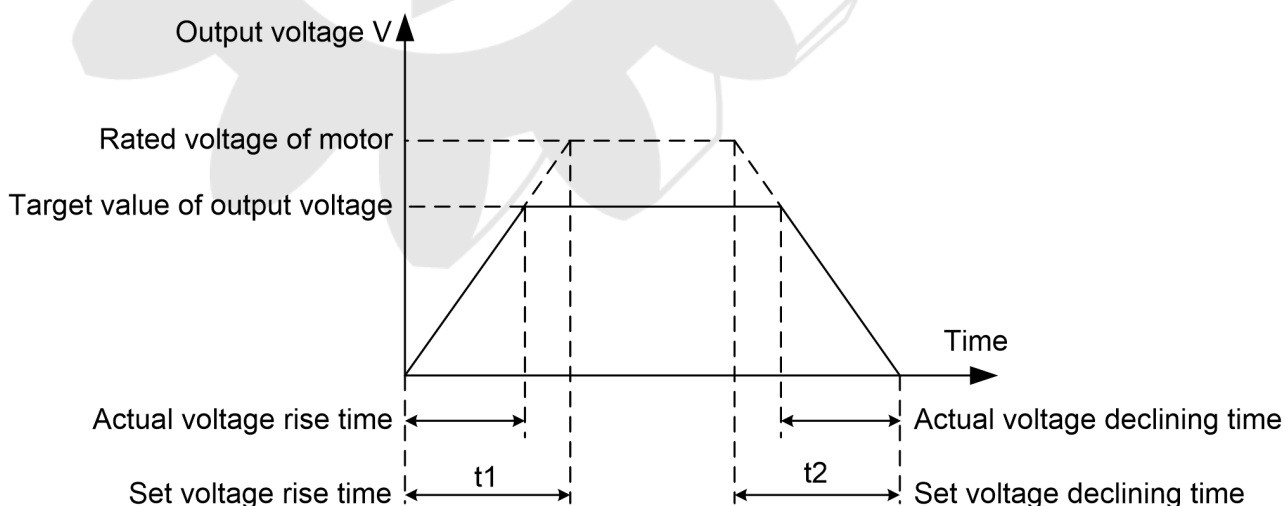

Figure 5-5 V/f detach diagram

04 Input Terminal Parameters

04-00	MI1 terminal function selection	Factory setting	1
04-01	MI2 terminal function selection	Factory setting	2
04-02	MI3 terminal function selection	Factory setting	9
04-03	MI4 terminal function selection	Factory setting	0
04-04	MI5 Terminal function selection(high-speed pulse optional)	Factory setting	0
04-05	Reserved	Factory setting	0
04-06	Reserved	Factory setting	0
04-07	Reserved	Factory setting	0

These parameters are used to set the function of the digital multi-function input terminal Terminal. The functions that can be selected are shown in the following table:

Setting value	Function	Description
0	No function	It is recommended to set the unused terminals to “no function” to prevent malfunction.
1	Forward running(FWD)	Control inverter forward and reverse running through external terminals.
2	Reverse running(REV)	
3	Three-wire control	This terminal is used to determine the inverter operation mode is the three-wire control mode. For details, please refer to the description of parameter 04-09 (terminal command mode).
4	Forward jog(FJOG)	Jog running frequency, jog acceleration and deceleration time, see the description of parameters 09-00, 09-01, 09-02.
5	Reverse jog(RJOG)	
6	Terminal UP	The frequency increment and decrement instructions are modified when the frequency is given by the external terminal. When the frequency source is set to digital setting, the set frequency can be adjusted up and down.
7	Terminal DOWN	
8	Coast to stop	The inverter blocks the output, and the motor's stopping process is not controlled by the inverter.
9	Fault reset(RESET)	A fault reset can be achieved by using a terminal for fault reset. Same as keyboard RESET.
10	Run pause	The inverter decelerates to stop, but all running parameters are memorized. Such as PLC parameters, wobble frequency parameters, PID parameters. After the terminal signal disappears, the inverter returns to the operating state before stopping.
11	Normally open input for external fault	When the signal is valid, the inverter reports the fault EF and performs fault processing according to the fault protection action mode (details participate in parameters 11-47).
12	Multi-step speed terminal 1	Through the combination of the states of the four terminals, the 16-speed setting or the setting of 16 other commands can be realized. See appendix 1 for details.
13	Multi-step speed terminal 2	
14	Multi-step speed terminal 3	
15	Multi-step speed terminal 4	

Setting value	Function	Description
16	Acceleration / deceleration time selection terminal 1	Through the four states of the two terminals, four types of acceleration and deceleration time are selected. See Table 2 for details.
17	Acceleration / deceleration time selection terminal 2	
18	Frequency source switching	According to the setting of the frequency source selection parameter (00-17), when switching between two frequency sources is set as the frequency source, the terminal is used to switch between the two frequency sources.
19	UP/DOWN set to clear (terminal, keyboard)	When the frequency is given as digital timing, this terminal can clear the frequency value changed by terminal UP/DOWN or keyboard UP/DOWN, so that the given frequency is restored to the value set by 00-06.
20	Run command switching terminal	When the command source is terminal control (00-00=1), this terminal can switch between terminal control and keyboard control. When the command source is communication control (00-00=2), this terminal can switch between communication control and keyboard control.
21	Acceleration / deceleration prohibited	Ensure that the inverter is not affected by external signals (except the stop command) and maintain the current output frequency.
22	PID Pause	The PID is temporarily disabled, and the inverter maintains the current output frequency.
23	PLC status reset	The PLC pauses during execution, and when running again, you can use this terminal to restore the inverter to the initial state of the simple PLC.
24	Wobble frequency pause	The inverter outputs at the center frequency. The wobble frequency function is suspended.
25	Counter Input	Count pulse input terminal.
26	Counter reset	Clear the counter status.
27	Length counter input	Input terminal for length counting.
28	Length reset	Length clear
29	Torque control prohibited	The inverter is prohibited from torque control, the inverter enters the speed control mode
30	PULSE (pulse) frequency input (only valid for MI5)	MI5 functions as a pulse input terminal.
31	Reserved	Reserved
32	Immediate DC braking	When this terminal is valid, the inverter directly switches to the DC braking state
33	Normally closed input for external fault	When this signal is valid, the inverter reports fault EF and stops.
34	Frequency modification enable	When this function is valid, the inverter does not respond to changes in frequency commands.

Setting value	Function	Description
35	PID action direction is reversed	When this terminal is valid, the direction of PID action is reversed to the direction set in 10-03.
36	External stop terminal 1	During keyboard control, this terminal can be used to stop the inverter, which is equivalent to the function of the STOP key on the keyboard.
37	Control command switching terminal 2	This function is used to switch between terminal control and communication control.
38	PID integration pause	When this terminal is valid, the PID integral adjustment function is suspended, but other PID adjustments are still effective.
39	Frequency source X and keyboard set frequency switching	When this terminal is valid, the frequency source X is replaced with the frequency given by the keyboard (00-06)
40	Frequency source Y and keyboard set frequency switching	When this terminal is valid, the frequency source Y is replaced with the frequency given by the keyboard (00-06)
41	Reserved	
42	Reserved	
43	PID parameter switching	When the PID parameter switching condition selects the MI terminal (10-18=1), when this terminal is invalid, the PID parameter uses 10-05~10-07; when the terminal is valid, it uses 10-15~10-17;
44	Reserved	
45	Reserved	
46	Speed control/torque control switching	Switch the inverter between torque control and speed control mode. When this terminal is invalid, the inverter runs in the mode defined by 17-00 (Speed/Torque Control Mode). When this terminal is valid, it switches to another mode.
47	Emergency stop	When this terminal is valid, the inverter stops at the fastest speed, and the current is in the upper limit of the set current during this stop. This function is used to meet the occasions where the inverter needs to stop as soon as possible when the system is in an emergency state.
48	External stop terminal 2	In any command control mode (panel control, terminal control, communication control), the terminal can be used to decelerate the inverter to stop, and the deceleration time is fixed at 4 deceleration time.
49	Deceleration DC braking	When this terminal is valid, the inverter decelerates to the initial frequency of DC braking at stop, and then switches to DC braking.
50	Clear the current running time	When this terminal is valid, the timing time of the inverter's current operation is cleared. This function needs to be used in conjunction with the timing operation (09-42) and the current operation time arrival (09-53).

Attached Table 1 Multi-step speed command function description

Four multi-speed command terminals can be combined into 16 states, and these 16 states correspond to 16 command setting values. As shown in Table 1:

K4	K3	K2	K1	Command setting	Corresponding parameters
OFF	OFF	OFF	OFF	Multi-step speed command 0	05-00
OFF	OFF	OFF	ON	Multi-step speed command 1	05-01
OFF	OFF	ON	OFF	Multi-step speed command 2	05-02
OFF	OFF	ON	ON	Multi-step speed command 3	05-03
OFF	ON	OFF	OFF	Multi-step speed command 4	05-04
OFF	ON	OFF	ON	Multi-step speed command 5	05-05
OFF	ON	ON	OFF	Multi-step speed command 6	05-06
OFF	ON	ON	ON	Multi-step speed command 7	05-07
ON	OFF	OFF	OFF	Multi-step speed command 8	05-08
ON	OFF	OFF	ON	Multi-step speed command 9	05-09
ON	OFF	ON	OFF	Multi-step speed command 10	05-10
ON	OFF	ON	ON	Multi-step speed command 11	05-11
ON	ON	OFF	OFF	Multi-step speed command 12	05-12
ON	ON	OFF	ON	Multi-step speed command 13	05-13
ON	ON	ON	OFF	Multi-step speed command 14	05-14
ON	ON	ON	ON	Multi-step speed command 15	05-15

When the frequency source is selected as multi-step speed, the parameters 100.0% of 05-00~05-15 correspond to the maximum frequency max frequency 00-03. Multi-step speed command can not only be used as a multi-step speed function, but also can be used as a given source of PID, or as a voltage source for V/f separation control to meet the needs of switching between different given values.

Attached Table 2 Acceleration and deceleration time terminal function description

Terminal 2	Terminal 1	Acceleration or deceleration time selection	Corresponding parameters
OFF	OFF	Acceleration time 1	00-07,00-08
OFF	ON	Acceleration time 2	09-03,09-04
ON	OFF	Acceleration time 3	09-05,09-06
ON	ON	Acceleration time 4	09-07,09-08

04-08	MI Filter time	↗	Factory setting	0.010s
	Setting range	0.000s~1.000s		

Set the software filtering time for the terminal state of the MI terminal. If the input terminal of the application occasion is susceptible to interference and cause malfunctions, this parameter can be increased to enhance the anti-interference ability. However, the increase of the filtering time will cause the response of the MI terminal to become slow.

04-09	Terminal command mode	Factory setting	0
Setting range	0	Two-wire 1	
	1	Two-wire 2	
	2	Three-wire 1	
	3	Three-wire 2	
	4	Four-wire 1	

This parameter defines four different ways to control the operation of the inverter through the external terminal Terminal.

0: Two-wire mode 1: This mode is the most commonly used two-wire mode.

Terminal Reverse running is determined by TerminalMlx and Mly.

The terminal terminal function settings are as follows:

Terminal	Setting value	Description
Mlx	1	Forward running(FWD)
Mly	2	Reverse running(REV)

Among them, Mlx and Mly are the multi-function input terminals Terminal of MI1~MI5, the level is effective.

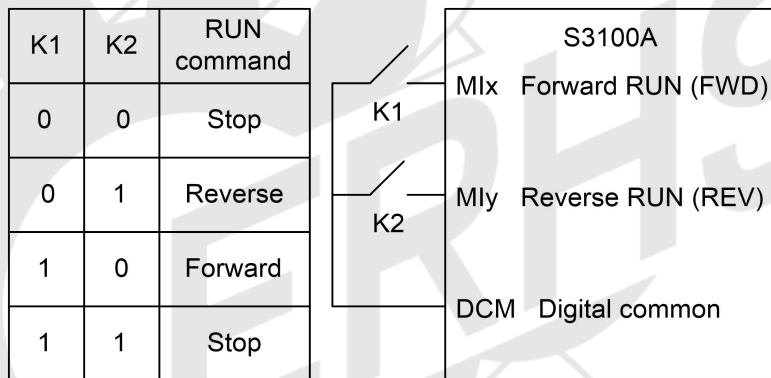

Figure 5-6 Two-wire mode 1

1: Two-wire mode 2: When using this mode, the terminal function of the Mlx terminal is the running enable terminal, and the terminal function of the Mly terminal determines the running direction.

The terminal terminal function settings are as follows:

Terminal	Setting value	Description
Mlx	1	Running command
Mly	2	Forward /Reverse

Among them, Mlx and Mly are the multi-function input terminals Terminal of MI1~MI5, the level is effective.

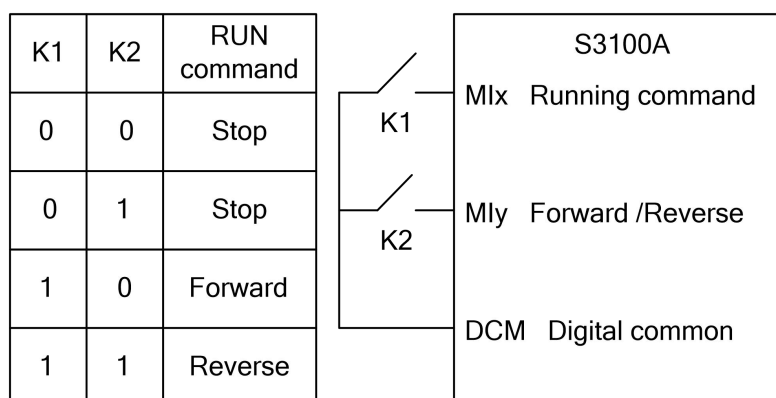

Figure 5-7 Two-wire mode 2

2: Three-wire control mode1: This mode MIn is the enable terminal, the direction is controlled by Mlx and Mly respectively.

The terminal terminal function settings are as follows:

Terminal	Setting value	Description
Mlx	1	Forward running(FWD)
Mly	2	Reverse running(REV)
MIn	3	Three-wire running control

When you need to run, you must first close the MIn terminal, and realize the forward or reverse control of the motor by the rising edge of the pulse of Mlx or Mly.

When it is necessary to stop, it must be achieved by disconnecting the terminal signal of the MIn terminal. Among them, Mlx, Mly, MIn are multi-function input terminals Terminal MI1 ~ MI5, Mlx, Mly are pulse effective, MIn is level effective.

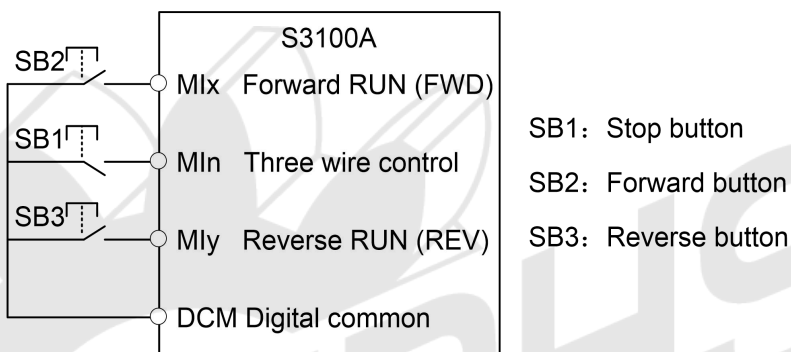

Figure 5-8 Three-wire control mode 1

3: Three-wire control mode 2: The enable terminal I in this mode is MIn, the running command is given by Mlx, and the direction is determined by the state of Mly.

The terminal terminal function settings are as follows:

Terminal	Setting value	Description
Mlx	1	Running command
Mly	2	Forward /Reverse
MIn	3	Three-wire running control

When you need to run, you must first close the MIn terminal, the Mlx pulse rising edge generates the motor running signal, and the Mly state generates the motor direction signal.

When it is necessary to stop, it must be achieved by disconnecting the terminal signal of the MIn terminal. Among them, Mlx, Mly, and MIn are the multi-function input terminals of MI1 to MI5, Mlx is pulse effective, and Mly, MIn are level effective.

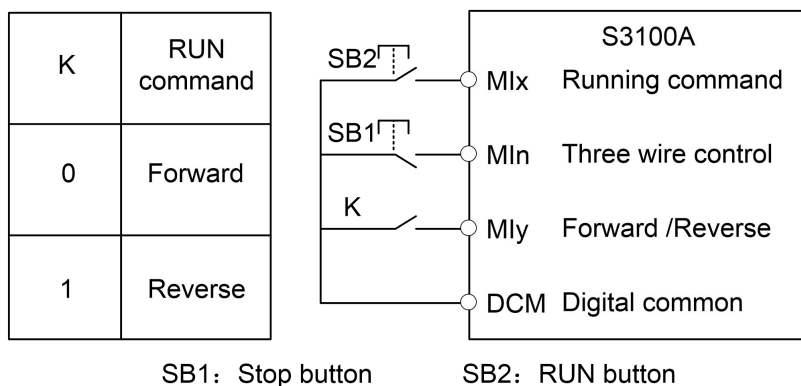

Figure 5-9 Three-wire control mode 2

04-10	Terminal UP/DOWN change rate	↗	Factory setting	1.00Hz/s
	Setting range	0.001Hz/s~65.535Hz/s		

Used to set the terminal UP/DOWN to adjust the set frequency, the speed of frequency change, that is the amount of frequency change per second.

When 00-25 (frequency decimal point) is 2, the value range is 0.001Hz/s~65.535Hz/s. When 00-25 (frequency decimal point) is 1, the value range is 0.01Hz/s~655.35Hz/s.

04-11	AVI curve 1 lower limit	↗	Factory setting	0.10V
	Setting range	0.00V~04-13		
04-12	Corresponding setting of AVI curve 1 lower limit	↗	Factory setting	0.0%
	Setting range	-100.0%~+100.0%		
04-13	AVI curve 1 upper limit	↗	Factory setting	10.00V
	Setting range	04-11~+10.00V		
04-14	Corresponding setting of AVI curve 1 upper limit	↗	Factory setting	100.0%
	Setting range	-100.0%~+300.0%		
04-15	AVI1 filter time	↗	Factory setting	0.10s
	Setting range	0.00s~10.00s		

The relationship between the above parameter analog input voltage and the setting value it represents.

When the analog input voltage exceeds the set range of the maximum input or minimum input, it will be calculated as the maximum input or minimum input.

When the analog input is current input, 0mA~20mA current corresponds to 0V~5V Voltage.

In different applications, the meaning of the nominal value corresponding to 100.0% of the analog setting is different. For details, please refer to the description of each application.

The following illustrations show two typical settings:

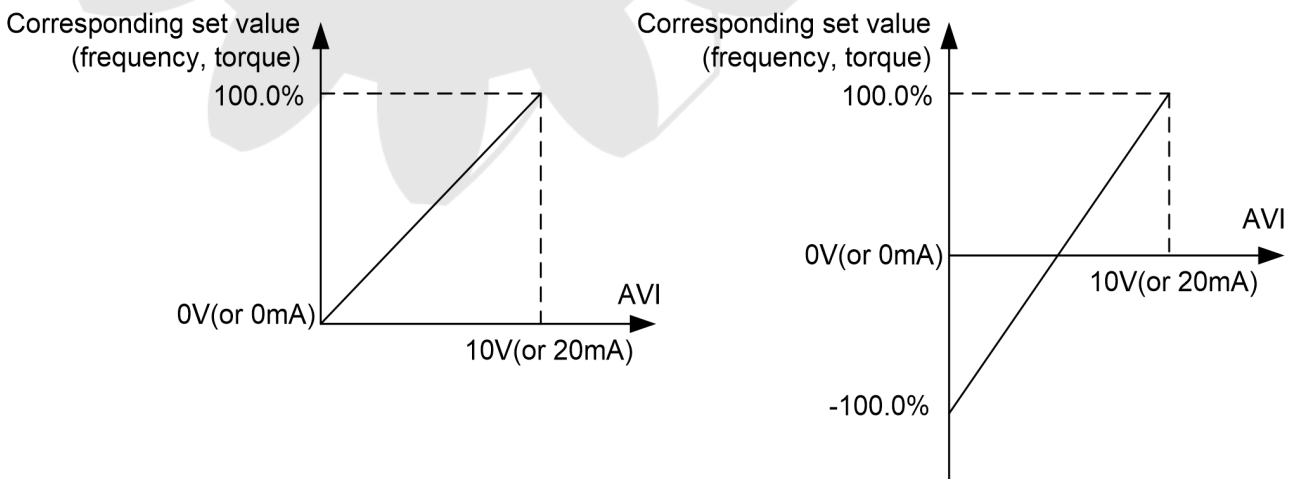

Figure 5-10 Correspondence relationship between analog input and set value

AVI1 input filter time: adjust the sensitivity of analog input. Properly increasing this value can enhance the anti-interference of the analog quantity, but it will reduce the sensitivity of the analog input.

04-16	AVI curve 2 lower limit	↗	Factory setting	1.00V
	Setting range	0.00V~04-18		
04-17	Corresponding setting of AVI curve 2 lower limit	↗	Factory setting	0.0%
	Setting range	-100.0%~+100.0%		
04-18	AVI curve 2 upper limit	↗	Factory setting	5.00V
	Setting range	04-16~+10.00V		
04-19	Corresponding setting of AVI curve 2 upper limit	↗	Factory setting	100.0%
	Setting range	-100.0%~+300.0%		
04-20	AVI2/ACI filter time	↗	Factory setting	0.10s
	Setting range	0.00s~10.00s		

For the method of setting AVI curve 2 function, please refer to the description of AVI curve 1.

Analog AVI2/ACI can support 0~10V or 0~20mA input. When AVI2/ACI selects 0~20mA input, the corresponding Voltage of 20mA is 5V.

04-23	Panel potentiometer curve lower limit value	↗	Factory setting	0.10V
	Setting range	-10.00V~04-25		
04-24	Corresponding setting of panel potentiometer curve lower limit value	↗	Factory setting	0.0%
	Setting range	-100.0%~+100.0%		
04-25	Panel potentiometer curve upper limit value	↗	Factory setting	9.90V
	Setting range	04-23~+10.00V		
04-26	Corresponding setting of panel potentiometer curve upper limit value	↗	Factory setting	100.0%
	Setting range	-100.0%~+150.0%		
04-27	Filter time of panel potentiometer	↗	Factory setting	0.10s
	Setting range	0.00s~10.00s		

For how to use the panel potentiometer curve function, please refer to the description of AVI Curve 1.

04-28	Pulse minimum input	↗	Factory setting	0.00kHz
	Setting range	0.00kHz~04-30		
04-29	Corresponding setting of pulse minimum input	↗	Factory setting	0.0%
	Setting range	-100.0%~100.0%		
04-30	Pulse maximum input	↗	Factory setting	50.00kHz
	Setting range	04-28~100.00kHz		
04-31	Corresponding setting of pulse maximum input	↗	Factory setting	100.0%
	Setting range	-100.0%~100.0%		
04-32	PULSE filter time	↗	Factory setting	0.10s
	Setting range	0.00s~10.00s		

This group of parameters is used for setting, the relationship between MI5 pulse frequency and the corresponding setting.

The pulse frequency can only be input to the inverter through the MI5 channel. The application of this group of functions is similar to AVI curve 1, please refer to the description of AVI curve 1.

04-33	AVI curve selection		↗	Factory setting	321
	Setting range	Single digit	AVI 1 curve selection		
		1	AVI curve 1(2 points, refer to 04-11~04-14)		
		2	AVI curve 2(2 points, refer to 04-16~04-19)		
		3	Reserved		
		4	Reserved		
		5	Reserved		
		Tens digital	AVI2/ACI curve selection, same as above		
	Hundreds digital	Reserved			

The single digit and tens digital of this parameter are used to select the setting curve corresponding to analog input AVI1, AVI2/ACI respectively.

Two kinds of analog input can choose any one of two kinds of curves.

04-34	AVI is less than the minimum input setting selection		↗	Factory setting	000
	Setting range	Single digit	AVI1 is less than the minimum input setting selection		
		0	Corresponding analog lower limit		
		1	0.0%		
		Tens digital	AVI2/ACI is less than the minimum input setting selection, same as above		

This parameter is used to select the analog value when the analog input voltage is less than the set "minimum input". The analog lower limit value refers to the less limit value of parameters 04-11 and 04-16.

If the selection is 1, when the AVI input is less than the minimum input, the corresponding setting of the analog quantity is 0.0%.

04-35	MI1 delay time		↗	Factory setting	0.0s
	Setting range	0.0s~3600.0s			
04-36	MI2 delay time		↗	Factory setting	0.0s
	Setting range	0.0s~3600.0s			
04-37	MI3 delay time		↗	Factory setting	0.0s
	Setting range	0.0s~3600.0s			

It is used to set the delay time for the inverter to change the terminal state when the MI terminal changes.

Currently, only MI1, MI2, and MI3 have the function of setting the delay time.

04-38	MI terminal valid mode selection 1		Factory setting	0
	Setting range	0	High level valid	
		1	Low level valid	
		Single digit	MI1	
		Tens digital	MI2	
		Hundreds digital	MI3	
		Thousands digital	MI4	
		Ten thousands digital	MI5	

Used to set the active status mode of the digital input terminal. When the selection is active high, the corresponding MI terminal is valid when connected to the DCM, and the disconnection is invalid. When the selection is active low, the corresponding MI terminal is invalid when it is connected to the DCM, and the disconnection is valid.

05 Multi-Speed, Simple PLC Control

The S3100A's multi-speed command is more abundant than the normal multi-speed. In addition to the multi-speed function, it can also be used as a voltage source for V/f separation and a given source of process PID. For this reason, the dimension of the multi-speed command is a relative value.

05-00	Multi-step speed command 0	✓	Factory setting	0.0%
05-01	Multi-step speed command 1	✓	Factory setting	0.0%
05-02	Multi-step speed command 2	✓	Factory setting	0.0%
05-03	Multi-step speed command 3	✓	Factory setting	0.0%
05-04	Multi-step speed command 4	✓	Factory setting	0.0%
05-05	Multi-step speed command 5	✓	Factory setting	0.0%
05-06	Multi-step speed command 6	✓	Factory setting	0.0%
05-07	Multi-step speed command 7	✓	Factory setting	0.0%
05-08	Multi-step speed command 8	✓	Factory setting	0.0%
05-09	Multi-step speed command 9	✓	Factory setting	0.0%
05-10	Multi-step speed command 10	✓	Factory setting	0.0%
05-11	Multi-step speed command 11	✓	Factory setting	0.0%
05-12	Multi-step speed command 12	✓	Factory setting	0.0%
05-13	Multi-step speed command 13	✓	Factory setting	0.0%
05-14	Multi-step speed command 14	✓	Factory setting	0.0%
05-15	Multi-step speed command 15	✓	Factory setting	0.0%
	Setting range	-100.0%~100.0%		

The multi-speed command can be used in three situations: as a frequency source, as a voltage source for V/f separation, as a set source for the process PID.

In three applications, the dimension of the multi-speed command is relative, ranging from -100.0% to 100.0%.

When used as a frequency source, it is a percentage of the relative maximum frequency max frequency; as a V/f separation voltage source, Relative to the percentage of the rated voltage of the motor; and since the PID given is originally a relative value, the multi-speed command does not require dimension conversion as the PID setting source.

The multi-speed command needs to be switched according to the different states of the multi-function input MI. For details, please refer to the 04 group.

05-16	Simple PLC operation mode	↗	Factory setting	0
	Setting range	0	Stop at the end of a single run	
		1	Keep the final value at the end of a single run	
		2	Keep circulating	

The simple PLC function has two functions: as a frequency source or as a voltage source with V/f separation.

Figure 5-11 is a schematic diagram of a simple PLC as a frequency source. When the simple PLC is used as the frequency source, the sign of 05-00~05-15 determines the running direction. If it is a negative value, it indicates that the inverter runs in the opposite direction.

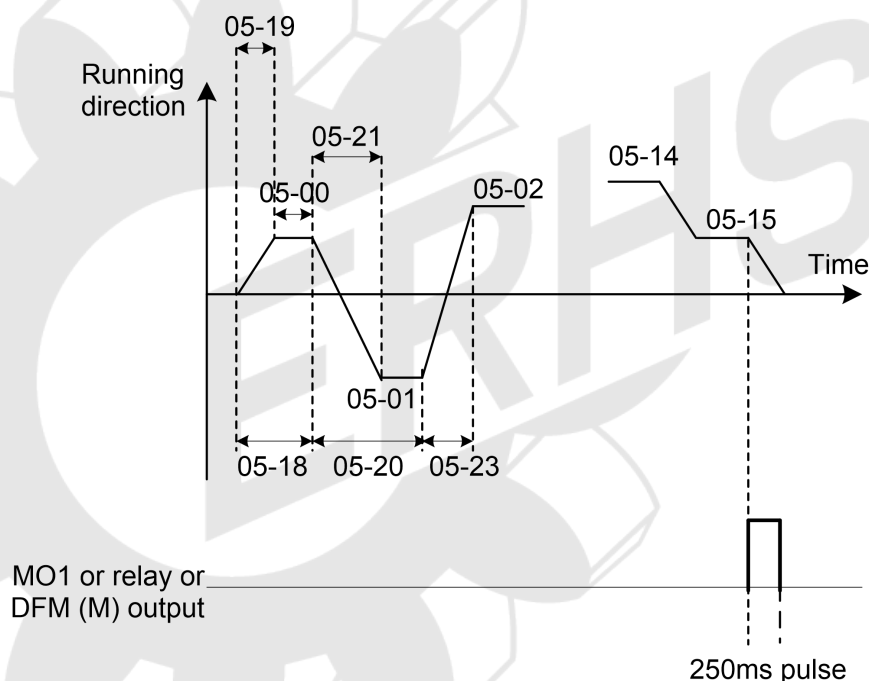

Figure 5-11 Schematic diagram of simple PLC

When used as a frequency source, the PLC has three operating modes, but not as a V/f voltage source. among them:

0: Stop at the end of a single run:

The inverter will automatically stop after completing a single cycle. It needs to give the run command again to start.

1: Keep the final value at the end of a single run:

After the inverter completes a single cycle, it automatically maintains the running frequency and direction of the last segment.

2: Keep circulating:

After the inverter completes one cycle, it automatically starts the next cycle until it stops when there is a stop command.

05-17	Simple PLC power failure memory selection		↗	Factory setting	0
	Setting range	Single digit	Power failure memory selection		
		0	Power failure no memory		
		1	Power failure memory		
		Tens digital	Stop memory selection		
		0	Stop no memory		
		1	Stop memory		

PLC power failure memory refers to memorizing the PLC's running stage and running frequency before power failure. It will continue to operate from the memory stage when it is next powered on. If no memory is selected, the PLC process will be restarted every time the power is turned on.

PLC stop memory is to record the previous PLC running stage and running frequency during stop, and continue to operate from the memory stage during the next operation. If you choose not to remember, the PLC process will be restarted every time you start.

05-18	Simple PLC stage 0 running time		↗	Factory setting	0.0s(h)
	Setting range	0.0s(h)~6500.0s(h)			
05-19	Simple PLC step 0 acceleration / deceleration time selection		↗	Factory setting	0
	Setting range	0~3			
05-20	Simple PLC stage 1 st running time		↗	Factory setting	0.0s(h)
	Setting range	0.0s(h)~6500.0s(h)			
05-21	Simple PLC step 1 st acceleration / deceleration time selection		↗	Factory setting	0
	Setting range	0~3			
05-22	Simple PLC stage 2 nd running time		↗	Factory setting	0.0s(h)
	Setting range	0.0s(h)~6500.0s(h)			
05-23	Simple PLC step 2 nd acceleration / deceleration time selection		↗	Factory setting	0
	Setting range	0~3			
05-24	Simple PLC stage 3 rd running time		↗	Factory setting	0.0s(h)
	Setting range	0.0s(h)~6500.0s(h)			
05-25	Simple PLC step 3 rd acceleration / deceleration time selection		↗	Factory setting	0
	Setting range	0~3			
05-26	Simple PLC stage 4 th running time		↗	Factory setting	0.0s(h)
	Setting range	0.0s(h)~6500.0s(h)			
05-27	Simple PLC step 4 th acceleration / deceleration time selection		↗	Factory setting	0
	Setting range	0~3			
05-28	Simple PLC stage 5 th running time		↗	Factory setting	0.0s(h)
	Setting range	0.0s(h)~6500.0s(h)			
05-29	Simple PLC step 5 th acceleration / deceleration time selection		↗	Factory setting	0
	Setting range	0~3			

05-30	Simple PLC stage 6 th running time	↗	Factory setting	0.0s(h)
	Setting range	0.0s(h)~6500.0s(h)		
05-31	Simple PLC step 6 th acceleration / deceleration time selection	↗	Factory setting	0
	Setting range	0~3		
05-32	Simple PLC stage 7 th running time	↗	Factory setting	0.0s(h)
	Setting range	0.0s(h)~6500.0s(h)		
05-33	Simple PLC step 7 th acceleration / deceleration time selection	↗	Factory setting	0
	Setting range	0~3		
05-34	Simple PLC stage 8 th running time	↗	Factory setting	0.0s(h)
	Setting range	0.0s(h)~6500.0s(h)		
05-35	Simple PLC step 8 th acceleration / deceleration time selection	↗	Factory setting	0
	Setting range	0~3		
05-36	Simple PLC stage 9 th running time	↗	Factory setting	0.0s(h)
	Setting range	0.0s(h)~6500.0s(h)		
05-37	Simple PLC step 9 th acceleration / deceleration time selection	↗	Factory setting	0
	Setting range	0~3		
05-38	Simple PLC stage 10 th running time	↗	Factory setting	0.0s(h)
	Setting range	0.0s(h)~6500.0s(h)		
05-39	Simple PLC step 10 th acceleration / deceleration time selection	↗	Factory setting	0
	Setting range	0~3		
05-40	Simple PLC stage 11 th running time	↗	Factory setting	0.0s(h)
	Setting range	0.0s(h)~6500.0s(h)		
05-41	Simple PLC step 11 th acceleration / deceleration time selection	↗	Factory setting	0
	Setting range	0~3		
05-42	Simple PLC stage 12 th running time	↗	Factory setting	0.0s(h)
	Setting range	0.0s(h)~6500.0s(h)		
05-43	Simple PLC step 12 th acceleration / deceleration time selection	↗	Factory setting	0
	Setting range	0~3		
05-44	Simple PLC stage 13 th running time	↗	Factory setting	0.0s(h)
	Setting range	0.0s(h)~6500.0s(h)		
05-45	Simple PLC step 13 th acceleration / deceleration time selection	↗	Factory setting	0
	Setting range	0~3		
05-46	Simple PLC stage 14 th running time	↗	Factory setting	0.0s(h)
	Setting range	0.0s(h)~6500.0s(h)		
05-47	Simple PLC step 14 th acceleration / deceleration time selection	↗	Factory setting	0
	Setting range	0~3		
05-48	Simple PLC stage 15 th running time	↗	Factory setting	0.0s(h)
	Setting range	0.0s(h)~6500.0s(h)		

05-49	Simple PLC step 15 th acceleration / deceleration time selection		↗	Factory setting	0
	Setting range	0~3			

05-50	Simple PLC running time unit		↗	Factory setting	0
	Setting range	0	s(Second)		
		1	h(Hour)		

05-51	Multi-speed command given mode		↗	Factory setting	0
	Setting range	0	Parameter 05-00 given		
		1	AVI1		
		2	AVI2/ACI		
		3	Reserved		
		4	PULSE		
		5	PID		
		6	The keyboard setting frequency (00-06) is given, UP/DOWN can be modified		

This parameter determines the given channel of Multi-step speed command 0.

06 Output Terminal Parameters

S3100A series inverters are equipped with a multi-function analog output terminal Terminal, a multi-function digital output terminal Terminal, a multi-function relay output terminal Terminal, a DFM terminal Terminal (can be used as high-speed pulse output terminal Terminal, also can be used as an open collector switch output).

06-00	MO1 output function selection	↗	Factory setting	1
06-01	Control board relay function selection(RA-RB-RC)	↗	Factory setting	2
06-02	Relay 2 function selection	↗	Factory setting	0
06-03	Reserved	↗	Factory setting	
06-04	DFM(M) output function selection	↗	Factory setting	0

The function descriptions of the multi-function output terminals are as follows:

Setting value	Function	Description
0	No output	Output terminal is invalid
1	Inverter is running	Indicates that the inverter is in running state and has an output frequency (which can be zero), at this time it outputs an ON signal
2	Fault output (stop)	When the inverter is faulty and the fault is stopped, the ON signal is output.
3	Frequency level detection FDT1 output	Please refer to the parameters 09-19,09-20
4	Frequency reached	Please refer to the parameters 09-21
5	Running at zero speed (No output when stopped)	When the inverter is running and the output frequency is 0, the ON signal is output. When the inverter is stopped, this signal is OFF.

Setting value	Function	Description
6	Motor overload pre-alarm	Before the overload protection action of the motor, the judgment is based on the threshold value of the overload pre-alarm, and the ON signal is output after the pre-alarm threshold is exceeded. Refer to parameters 11-00~11-02 for motor overload parameter setting.
7	Inverter overload pre-alarm	10s before the inverter overload protection occurs, output ON signal.
8	Set count value reached	When the count value reaches the value set in 13-08, the ON signal is output.
9	Designated count value reached	When the count value C reaches the value set in 13-09, the ON signal is output. For counting function, please refer to 13 groups of function description
10	Length reached	When the detected actual length exceeds the length set by 13-05, the ON signal is output.
11	PLC cycle completed	When the simple PLC completes one cycle of operation, it outputs a pulse signal with a width of 250ms.
12	Cumulative running time arrived	When the cumulative running time of the inverter exceeds the time set in 09-17, it outputs an ON signal.
13	Frequency limited	When the set frequency exceeds the upper limit frequency or lower limit frequency, and the output frequency of the inverter reaches the upper limit frequency or lower limit frequency, an ON signal is output.
14	Torque limited	In the speed control mode of the frequency converter, when the output torque reaches the torque limit value, the frequency converter is in the stall protection state and outputs an ON signal at the same time.
15	Ready for run	When the power supply of the main circuit and the control circuit of the inverter has stabilized, and the inverter has not detected any fault information, and the inverter is in a operable state, it outputs an ON signal.
16	AVI1>AVI2/ACI	When the value of analog input AVI1 is greater than the input value of AVI2/ACI, an ON signal is output.
17	Upper limit frequency reached	When the running frequency reaches the upper limit frequency, the ON signal is output.
18	Lower limit frequency reached (operation valid)	When the running frequency reaches the lower limit frequency, the ON signal is output. The output is OFF in the stop state.
19	Undervoltage state output	When the inverter is undervoltage state, it outputs ON signal.
20	Communication setting	Please refer to the communication protocol.
21	Reserved	Reserved
22	Reserved	Reserved
23	Zero speed running 2 (also output when stopped)	When the output frequency of the inverter is 0, the ON signal is output. This signal is also ON in the stop state.
24	Cumulative power-on time arrival	When the cumulative power-on time (08-13) of the inverter exceeds the set time of 09-16, it outputs an ON signal.
25	Frequency level detection FDT2 output	Please refer to the parameters 09-28,09-29

Setting value	Function	Description
26	Frequency 1 reaches the output	Please refer to the parameters 09-30,09-31
27	Frequency 2 reaches the output	Please refer to the parameters 09-32,09-33
28	Current 1 reaches the output	Please refer to the parameters 09-38,09-39
29	Current 2 reaches the output	Please refer to the parameters 09-40,09-41
30	Timing reached	When the timing function selection (09-42) is valid, the inverter will output an ON signal after the current running time of the inverter reaches the set time.
31	AV11 input exceeds limit	When the value of analog input AV11 is greater than 09-46 (AV11 input protection upper limit) or less than 09-45 (AV11 input protection lower limit), ON signal is output.
32	Lost load	When the inverter is in the load drop state, it outputs ON signal.
33	Reverse running	When the inverter is running in reverse, output ON signal
34	Zero current state	Please refer to the parameters 09-34,09-35
35	Module temperature reached	Inverter module radiator temperature (08-08) reaches the set module temperature reached value(09-47), output ON signal
36	Software current limit exceeded	Please refer to the parameters 09-36,09-37
37	Lower limit frequency reached (also output when stopped)	When the running frequency reaches the lower limit frequency, the ON signal is output. The signal is also ON in the stop state.
38	Warning output	When the inverter fails, and the fault handling mode is Continue to run, the inverter warning output.
39	Reserved	Reserved
40	Current running time reached	When the inverter's current running time exceeds the time set in 09-53, it outputs an ON signal.

06-05	DFM terminal output mode selection		↗	Factory setting	0
	Setting range	0	Pulse output(DFM(P))		
		1	Switch output(DFM(M))		

The DFM terminal is a programmable multiplex terminal, which can be used as a high-speed pulse output terminal (DFM(P)) or an open collector switching output terminal (DFM(M)).

When DFM(P) is output as a pulse, please refer to 06-06 for DFM(P) related functions. The maximum frequency of the output pulse is 100kHz.

When DFM(M) is output as a switch, please refer to 06-04 for DFM(M) related functions.

06-06	DFM(P) output function selection	↗	Factory setting	0
06-07	AFM output function selection	↗	Factory setting	0
06-08	AFM2 option of the output function (it is optional for large kW)	↗	Factory setting	1

DFM (P) terminal output pulse frequency range is 0.01kHz ~ 06-09 (DFM (P) output maximum frequency), 06-09 can be set between 0.01kHz ~ 100.00kHz.

Analog output AFM output range is 0V ~ 10V. The relationship between the range of pulse output or analog output and the scaling of corresponding functions is shown in the following table:

Setting value	Function	Pulse or analog output 0.0%~100.0% corresponding function
0	Running frequency	0 to max output frequency
1	Set frequency	0 to max output frequency
2	Output current	0 to 2 times of motor rated current
3	Output torque	0 to 2 times of motor rated torque
4	Output power	0 to 2 times rated power
5	Output voltage	0 to 1.2 times of inverter rated voltage
6	PULSE input	0.01kHz~100.00kHz
7	AVI1	0V~10V
8	AVI2/ACI	0V~10V(or 0~20mA)
9	Reserved	
10	Length	0 to maximum set length
11	Count value	0 to maximum count value
12	Communication setting	0.0%~100.0%
13	Motor rotation speed	0~The rotation speed corresponding to maximum output frequency
14	Output current	0.0A~1000.0A
15	BUS voltage	0.0V~1000.0V

06-09	DFM (P) output maximum frequency	↗	Factory setting	50.00kHz
	Setting range	0.01kHz~100.00kHz		

When the DFM terminal is selected as the pulse output, this parameter is used to select the maximum frequency value of the output pulse.

06-10	AFM zero offset coefficient	↗	Factory setting	0.0%
	Setting range	-100.0%~+100.0%		
06-11	AFM gain	↗	Factory setting	1.00
	Setting range	-10.00~+10.00		
06-12	AFM2 zero offset coefficient	↗	Factory setting	0.0%
	Setting range	-100.0%~+100.0%		
06-13	AFM2 gain	↗	Factory setting	1.00
	Setting range	-10.00~+10.00		

The above parameters are generally used to correct the zero drift of the analog output and the deviation of the output amplitude. It can also be used to customize the desired AFM output curve.

If the zero offset is represented by "b", the gain is represented by k, the actual output is represented by Y, and the standard output is represented by X, then the actual output is:

$Y=kX+b$. Among them, the zero deviation coefficient of AFM 100% corresponds to 10V, the standard output refers to the amount of 0V ~ 10V corresponding to the analog output without zero deviation and gain correction.

06-17	MO1 output delay time	↗	Factory setting	0.0s
06-18	Relay RA-RB-RC output delay time	↗	Factory setting	0.0s
06-19	Relay 2 output delay time	↗	Factory setting	0.0s
06-20	Reserved	↗	Factory setting	
06-21	DFM(M) output delay time	↗	Factory setting	0.0s
	Setting range	0.0s~3600.0s		

Set the delay time for the output terminal Terminal to change from the state to the actual output.

06-22	MO output terminal valid state selection	↗	Factory setting	0
	Setting range	0	Positive logic	
		1	Negative logic	
		Single digit	MO1	
		Tens digital	Relay RA-RB-RC	
		Hundreds digital	Reserved	
		Thousands digital	Reserved	
		Ten thousands digital	DFM(M)	

Define the output logic of output terminals MO1, relays RA-RB-RC and DFM(M).

0: positive logic, the digital output terminal and the corresponding common terminal are connected to the valid state, and disconnected to the invalid state;

1: Inverse logic, the digital output terminal and the corresponding common terminal are connected to the invalid state, and disconnected to the valid state.

07 Start and Stop Control Parameters

07-00	Startup mode		Factory setting	0
	Setting range	0	Direct start	
		1	Rotation speed tracking restart	
		2	Pre-excitation start	
		3	Reserved	

0: Direct start:

If the startup DC braking time is set to 0, the inverter starts to run from the startup frequency. If the startup DC braking time is not 0, then DC braking first, and then start running from the startup frequency. Applicable to small inertial loads, where the motor may rotate when starting.

1: Rotation speed tracking restart:

The inverter first judges the speed and direction of the motor, and then starts at the tracked motor frequency, and implements the smoothing of the rotating motor.

Start without sliding. It is suitable for restart after instantaneous power failure of large inertia load. In order to ensure the performance of speed tracking and restart, it is necessary to set the motor 01 group parameters accurately.

2: Pre-excitation start:

Used to establish the magnetic field before the motor runs. For the pre-excitation current and time, please refer to the description of parameters 07-03 and 07-04.

If the pre-excitation time is set to 0, the inverter cancels the pre-excitation process and starts from the startup frequency. If the pre-excitation time is not 0, pre-excitation first and then start, can improve the dynamic response performance of the motor.

07-01	Startup frequency		↗	Factory setting	0.00Hz
	Setting range	0.00Hz~10.00Hz			
07-02	Startup frequency holding time			Factory setting	0.0s
	Setting range	0.0s~100.0s			

The inverter starts to run from the startup frequency (07-01), after the startup frequency holding time (07-02), then accelerates to the target frequency according to the set acceleration time.

The startup frequency 07-01 is not limited by the lower limit frequency. However, when the set target frequency is less than the startup frequency, the inverter does not start and is in a standby state.

During the switching between forward and reverse rotation, the startup frequency holding time has no effect. The startup frequency holding time is not included in the acceleration time, but included in the running time of the simple PLC.

07-03	Startup DC braking current / pre-excitation current		Factory setting	0%
	Setting range	0%~100%		
07-04	Startup DC braking time/pre-excitation time		Factory setting	0.0s
	Setting range	0.0s~100.0s		

Startup DC braking is only effective when the starting mode is direct start. At this time, the inverter performs DC braking according to the set startup DC braking current, and then starts running after the startup DC braking time. If the DC braking time is set to 0, DC braking is invalid. The greater the DC braking current, the greater the braking force.

If the startup mode is asynchronous motor pre-excitation start, the inverter first establishes the magnetic field according to the set pre-excitation current, and then starts running after the pre-excitation time.

If the pre-excitation time is set to 0, the pre-excitation is invalid and starts directly.

The startup DC braking current/pre-excitation current is a percentage of the rated current of the inverter.

07-05	Stop mode		↗	Factory setting	0
	Setting range	0	Decelerate to stop		
		1	Coast to stop		

0: Decelerate to stop after the stop command is valid, the inverter reduces the output frequency according to the deceleration time, and stops after the frequency drops to 0.

1: After the coast stop command is valid, the inverter immediately terminates the output, and the motor coasts to stop according to the mechanical inertia.

07-06	Starting frequency of DC braking at stop		↗	Factory setting	0.00Hz
	Setting range	0.00Hz~Max frequency			
07-07	DC braking waiting time at stop		↗	Factory setting	0.0s
	Setting range	0.0s~100.0s			

07-08	DC braking current at stop	↗	Factory setting	50%
	Setting range	0%~100%		
07-09	DC braking time at stop	↗	Factory setting	0.0s
	Setting range	0.0s~100.0s		

Starting frequency of DC braking at stop: When the running frequency is reduced to this frequency during deceleration to stop, the DC braking process starts.

Waiting time for DC braking at stop: After the running frequency is reduced to the initial frequency of DC braking at stop, the inverter will stop output for a period of time before starting the DC braking process. It is used to prevent overcurrent and other faults that may be caused by starting DC braking at a higher speed.

DC braking current at stop: refers to the output current Output current during DC braking, as a percentage of the motor rated current. The larger the value, the stronger the braking, but the greater the heat generated by the motor and inverter.

DC braking time at stop: The time the DC braking amount is maintained. This value is 0, the DC braking process is canceled. The DC braking process during shutdown is shown in the schematic diagram in Figure 5-12.

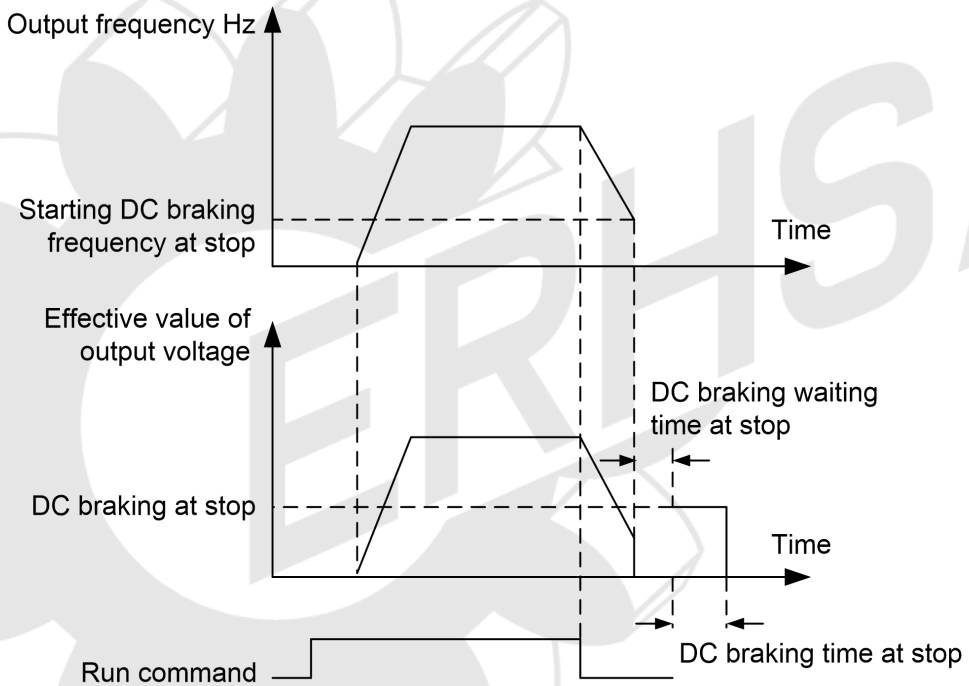

Figure 5-12 Schematic diagram of DC braking at shutdown

07-10	Brake usage	↗	Factory setting	80%
	Setting range	0%~100%		

It is only valid for the inverter with built-in braking unit.

The higher the braking usage rate, the stronger the braking effect, but the voltage fluctuation of the inverter bus voltage during braking is large.

07-11	Acceleration and deceleration mode	Factory setting	0
	Setting range	0	Linear acceleration / deceleration
		1	S curve acceleration / deceleration A
		2	S curve acceleration / deceleration B

Select the frequency change method of the inverter during start and stop.

0: linear acceleration and deceleration

The output frequency increases or decreases in a straight line. 4 kinds of acceleration/deceleration time can be selected through multi-function digital input terminals (04-00~04-04).

1: S curve acceleration and deceleration A

The output frequency increases or decreases according to the S curve. The S curve is used in places that require gentle start or stop, such as elevators and conveyor belts. Parameters 07-12 and 07-13 respectively define the time proportion of the start and end segments of the S curve acceleration and deceleration

2: S curve acceleration and deceleration B

In this S curve acceleration/deceleration B, the rated frequency of the motor is always the inflection point of the S curve. As shown in Figure 5-14. It is generally used in high-speed areas above the rated frequency that require rapid acceleration and deceleration.

When the set frequency is above the rated frequency, the acceleration/deceleration time is:

$$t = \left(\frac{4}{9} \times \left(\frac{f}{f_b} \right)^2 + \frac{5}{9} \right) \times T$$

Among them, f is the set frequency, fb is the rated frequency of the motor, and T is the time from 0 frequency acceleration to the rated frequency fb.

07-12	S curve start time ratio		Factory setting	30.0%
	Setting range	0.0%~(100.0%-07-13)		
07-13	S curve end time ratio		Factory setting	30.0%
	Setting range	0.0%~(100.0%-07-12)		

Parameters 07-12 and 07-13 respectively define the start and end time ratios of the acceleration and deceleration A of the S curve. The two parameters must meet: 07-12 + 07-13 ≤ 100.0%.

In Figure 5-13, t1 is the parameter defined by parameter 07-12. During this period of time, the slope of the output frequency change gradually increases. t2 is the time defined by parameter 07-13. During this time period, the slope of the output frequency change gradually changes to 0.

During the time between t1 and t2, the slope of the output frequency change is fixed, that is, linear acceleration and deceleration are performed in this interval.

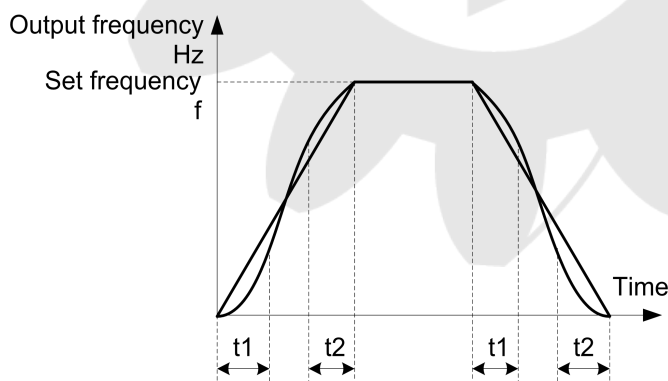

Figure 5-13 S curve acceleration and deceleration A

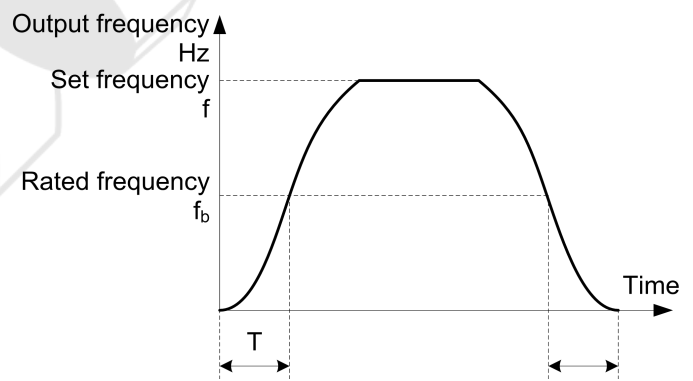

Figure 5-14 S curve acceleration and deceleration B

07-14	Rotation speed tracking mode		↗	Factory setting	0
	Setting range	0	Start from stop frequency		
		1	Start from zero speed		
		2	Start from maximum frequency		

In order to complete the speed tracking process in the shortest time, choose the method of inverter tracking:

0: Track down from the frequency of power failure, this method is usually selected.

1: Start tracking from 0 frequency and use when the power is off for a long time before restarting.

2: Track down from the maximum frequency, generally used for generating loads.

07-15	Rotation speed tracking speed		Factory setting	20
	Setting range	1~100		

When the speed tracking is restarted, select the speed of the speed tracking.

The larger the parameter, the faster the tracking speed. However, if the setting is too large, the tracking effect may be unreliable.

08 Man-machine Interface Parameters

08-00	User password	↗	Factory setting	0
	Setting range	0~65535		

08-00 sets any non-zero number, the password protection function takes effect. The next time you enter the menu, you must enter the password correctly, otherwise you cannot view and modify the function parameters, please remember the set user password.

Set 08-00 to 00000, then clear the set user password and invalidate the password protection function.

08-01	QUICK/JOG key function selection		Factory setting	3
	Setting range	0	QUICK/JOG invalid	
		1	Keyboard command channel and remote command channel (terminal Terminal command channel or communication command channel) switch	
		2	Forward and reverse switching	
		3	Forward jog	
		4	Reverse jog	
		5	Counter 2 cleared	

QUICK/JOG is a multi-function key, and the function of QUICK/JOG key can be set through this parameter. You can use this key to switch between stop and running.

0: This button has no function.

1: Switch between keyboard command and remote operation. Refers to the switching of the command source, that is, the switching between the current command source and the keyboard control (local operation). If the current command source is keyboard control, the function of this key is invalid.

2: Forward and reverse switching Use this key to switch the direction of the frequency command. This function is only valid when the command source is the command channel of the operation panel.

3: Forward jog (FJOG) can be achieved through this key.

4: Reverse jog (RJOG) can be realized through this key.

08-02	STOP/RESET key function	↗	Factory setting	1
	Setting range	0	Only in the keyboard operation mode, the STOP/RESET key stop function is effective	
		1	In any operation mode, the STOP/RESET key stop function is effective	

08-03	LED operation display parameter 1	↗	Factory setting	1F
Setting range	0000~FFFF			
	Bit00	Running frequency1(Hz)		
	Bit01	Setting frequency(Hz)		
	Bit02	BUS Voltage(V)		
	Bit03	Output voltage(V)		
	Bit04	Output current(A)		
	Bit05	Output power(kW)		
	Bit06	Output torque(%)		
	Bit07	MI input status		
	Bit08	MO output status		
	Bit09	AVI1 voltage(V)		
	Bit10	AVI2/ACI voltage(V)		
	Bit11	Reserved		
	Bit12	Count value		
	Bit13	Length		
	Bit14	Load speed		
Bit15	PID setting			
If the above parameters need to be displayed during operation, set the corresponding position to 1, set the binary number to hexadecimal and set it to 08-03.				

08-04	LED operation display parameter 2	↗	Factory setting	0
Setting range	0000~FFFF			
	Bit00	PID feedback		
	Bit01	PLC stage		
	Bit02	PULSE input pulse frequency(kHz)		
	Bit03	Running frequency 2(Hz)		
	Bit04	Remaining running time		
	Bit05	AVI1 voltage Before correction(V)		
	Bit06	AVI2/ACI voltage Before correction(V)		
	Bit07	Counter 2		
	Bit08	Line speed		
	Bit09	Current power-on time(Hour)		
	Bit10	Current running time(Min)		
	Bit11	PULSE Input pulse frequency(Hz)		
	Bit12	Communication setting value		
Bit13	Reserved			

08-04	LED operation display parameter 2	↗	Factory setting	0
	Setting range	Bit14	Main frequency X display (Hz)	
		Bit15	Auxiliary frequency Y display (Hz)	
		If the above parameters need to be displayed during operation, set the corresponding position to 1, set the binary number to hexadecimal and set it to 08-04.		

Running display parameters are used to set the parameters that can be viewed when the inverter is in running state.

The maximum number of status parameters available for viewing is 32, and the status parameters to be displayed are selected according to the binary bits of the 08-03 and 08-04 parameter values. The display order starts from the lowest bit of 08-03.

08-05	LED shutdown display parameters	↗	Factory setting	33
	Setting range	0000~FFFF		
		Bit00	Setting frequency(Hz)	
		Bit01	BUS voltage(V)	
		Bit02	MI input status	
		Bit03	MO output status	
		Bit04	AVI1 voltage(V)	
		Bit05	AVI2/ACI voltage(V)	
		Bit06	Reserved	
		Bit07	Count value	
		Bit08	Length	
		Bit09	PLC stage	
		Bit10	Load speed	
		Bit11	PID setting	
		Bit12	PULSE input pulse frequency(kHz)	
		Bit13	Counter 2	
	If the above parameters need to be displayed during operation, set the corresponding position to 1, set the binary number to hexadecimal and set it to 08-05.			

08-06	Load speed display coefficient	↗	Factory setting	1
	Setting range	0.0001~6.5000		

When the load speed Load speed needs to be displayed, this parameter is used to adjust the corresponding relationship between the inverter output frequency and the load speed Load speed. Refer to the instructions of 08-12.

08-07	Reserved		Factory setting	-
--------------	----------	--	-----------------	---

08-08	Inverter module radiator temperature	Factory setting	-
	Setting range	0.0°C~100.0°C	

Displays the temperature of the inverter module IGBT.

Different types of inverter modules have different IGBT over-temperature protection values.

08-09	Reserved	Factory setting	-
08-10	Software version No.	Factory setting	-

08-11	Cumulative running time	Factory setting	-
	Setting range	0h~65535h	

Cumulative running time of the inverter is displayed. When the running time reaches the set running time 09-17, the inverter's multi-function digital output function (12) outputs an ON signal.

08-12	Load speed display the number of decimal places	↗	Factory setting	20
	Setting range	Units: Number of decimal places for load speed Tens place: Number of decimal places for feedback speed		
		0	0 decimal place	
		1	1 decimal place	
		2	2 decimal places	
		3	3 decimal places	

Used to set the number of decimal places for load speed display. The following example illustrates the calculation method of load speed:

If the load speed display coefficient 08-06 is 2.000, the load speed decimal point number 08-12 is 2 (2 decimal points), when the inverter running frequency is 40.00Hz, the load speed is: $40.00 \times 2.000 = 80.00$ (2 decimal points display)

If the inverter is in a stopped state, the load speed is displayed as the speed corresponding to the setting frequency, that is, "set load speed". Taking the set frequency of 50.00Hz as an example, the load speed in the stop state is: $50.00 \times 2.000 = 100.00$ (2 decimal places display)

08-13	Cumulative power-on time	Factory setting	-
-------	--------------------------	-----------------	---

Shows the cumulative power-on time of the inverter since the factory.

When this time reaches the set power-on time (09-17), the inverter's multi-function digital output function (24) outputs an ON signal.

08-14	Cumulative power consumption	Factory setting	-
	Setting range	0~65535 degree	

Displays the cumulative power consumption of the inverter so far

09 Accessibility Parameters

09-00	Jog running frequency	↗	Factory setting	5.00Hz
	Setting range	0.00Hz~Max frequency		
09-01	Jog acceleration time	↗	Factory setting	20.0s
	Setting range	0.0s~6500.0s		

09-02	Jog deceleration time	↗	Factory setting	20.0s
	Setting range	0.0s~6500.0s		

Define the given frequency and acceleration/deceleration time of the inverter when jogging.

09-03	Acceleration time 2	↗	Factory setting	Type setting
09-04	Deceleration time 2	↗	Factory setting	Type setting
09-05	Acceleration time 3	↗	Factory setting	Type setting
09-06	Deceleration time 3	↗	Factory setting	Type setting
09-07	Acceleration time 4	↗	Factory setting	Type setting
09-08	Deceleration time 4	↗	Factory setting	Type setting
	Setting range	0.0s~6500.0s		

S3100A provides 4 groups of acceleration and deceleration time, respectively 00-07/00-08 and the above 3 groups of acceleration and deceleration time.

The definitions of the 4 groups of acceleration and deceleration times are exactly the same, please refer to the relevant descriptions of 00-07 and 00-08. Through different combinations of multi-function digital input terminals MI, you can switch to select 4 groups of acceleration and deceleration time. For specific usage, please refer to the relevant descriptions in parameters 04-00~04-05.

09-09	Jump frequency 1	↗	Factory setting	0.00Hz
	Setting range	0.00Hz~Max frequency		
09-10	Jump frequency 2	↗	Factory setting	0.00Hz
	Setting range	0.00Hz~Max frequency		
09-11	Jump frequency amplitude	↗	Factory setting	0.00Hz
	Setting range	0.00Hz~Max frequency		

When the set frequency is within the range of the jump frequency, the actual operating frequency will run at the jump frequency closer to the set frequency. By setting the jump frequency, the inverter can avoid the mechanical resonance point of the load.

The S3100A can set two jump frequency points. If both jump frequencies are set to 0, the jump frequency function is cancelled. Please refer to Figure 5-15 for the principle of jump frequency and jump frequency amplitude.

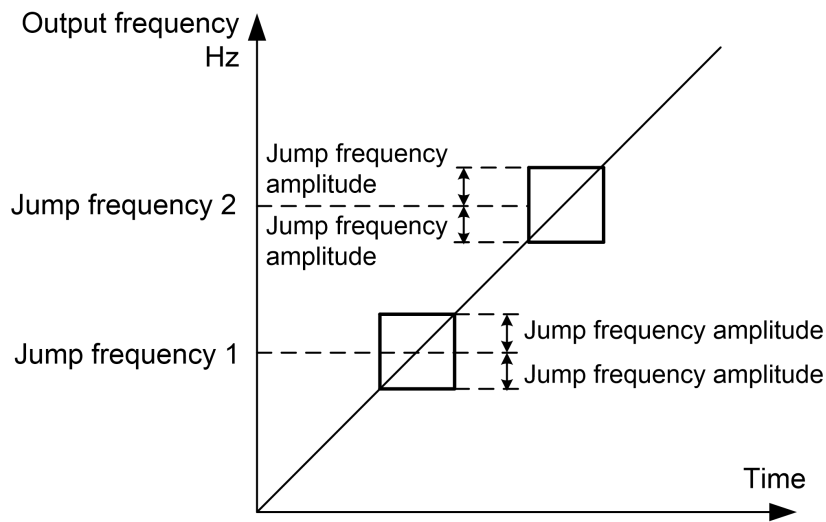

Figure 5-15 Schematic diagram of jumping frequency

09-12	Forward and reverse dead time		↗	Factory setting	0.0s
	Setting range	0.00s~3000.0s			

Set the transition time at the output 0Hz during the inverter forward and reverse transition, as shown in Figure 5-16:

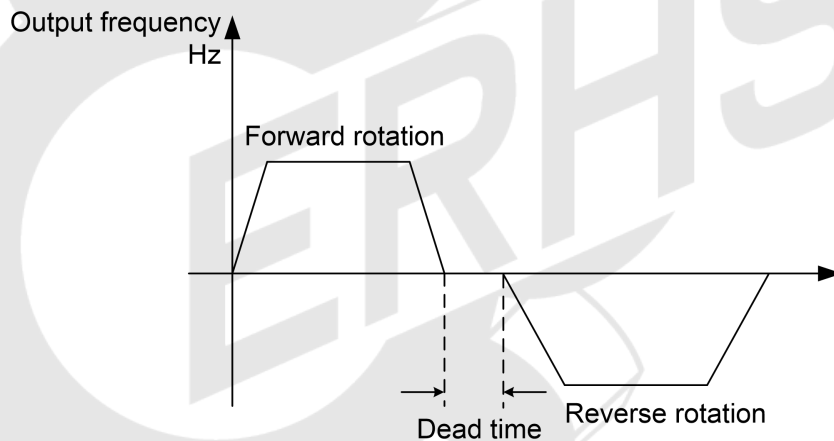

Figure 5-16 Schematic diagram of forward and reverse dead time

09-13	Reverse control enable		↗	Factory setting	0
	Setting range	0	Enabled		
		1	Disabled		

Use this parameter to set the inverter to set 09-13=1 when the motor is not allowed to reverse.

09-14	Operating mode with set frequency lower than lower limit frequency		↗	Factory setting	0
	Setting range	0	Run at the lower limit frequency		
		1	Downtime		
		2	Zero speed operation		

When the set frequency is lower than the lower limit frequency, the running state of the inverter can be selected by this parameter. S3100A provides three operating modes to meet various application requirements.

09-15	Drop control	↗	Factory setting	0.00Hz
	Setting range	0.00Hz~10.00Hz		

Refers to the output frequency drop value when the inverter is outputting the rated load. This function is generally used for load distribution when multiple motors drag the same load.

The droop control means that as the load increases, the output frequency of the inverter decreases, so that when multiple motors drag the same load, the output frequency of the motor in the load decreases more, which can reduce the load of the motor and realize the The load is even.

09-16	Set cumulative power-on arrival time	↗	Factory setting	0h
	Setting range	0h~65000h		

When the cumulative power-on time (08-13) reaches the power-on time set in 09-16, the inverter's multi-function output terminal Terminal (function 24) turns on.

09-17	Set cumulative running arrival time	↗	Factory setting	0h
	Setting range	0h~65000h		

Used to set the running time of the inverter.

When the accumulated running time (08-11) reaches this set running time, the inverter's multi-function output terminal Terminal (function 12) turns on.

09-18	Power-on operation protection options	↗	Factory setting	1
	Setting range	0	Run command is valid when power on	
		1	Run command is invalid when power on	

The parameter is 1, if the running command is valid when the inverter is powered on (such as the terminal running command is closed before powering on), the inverter does not respond to the running command, and the running command must be canceled once before the inverter is valid again response.

In addition, if this parameter is set to 1, if the running command is valid at the time of inverter fault reset, the inverter will not respond to the running command, and the running command must be removed before the running protection state can be eliminated.

Setting this parameter to 1 can prevent the danger caused by the motor responding to the running command when the power is turned on or the fault is reset without knowing it.

09-19	Frequency detection value(FDT1)	↗	Factory setting	50.00Hz
	Setting range	0.00Hz~Max frequency		

09-20	Frequency detection hysteresis(FDT1)	↗	Factory setting	5.0%
	Setting range	0.0%~100.0%(FDT1 Level)		

When the running frequency is greater than or equal to the frequency detection value, the inverter's multi-function output terminal (function 3) outputs an ON signal. When the frequency is lower than the detection value by a certain frequency value, the output ON signal is canceled.

The above parameters are used to set the detection value of the output frequency and the hysteresis value of the output operation release. Where 09-20 is the percentage of the hysteresis frequency relative to the frequency detection value 09-19. Figure 5-17 is a schematic diagram of the FDT function.

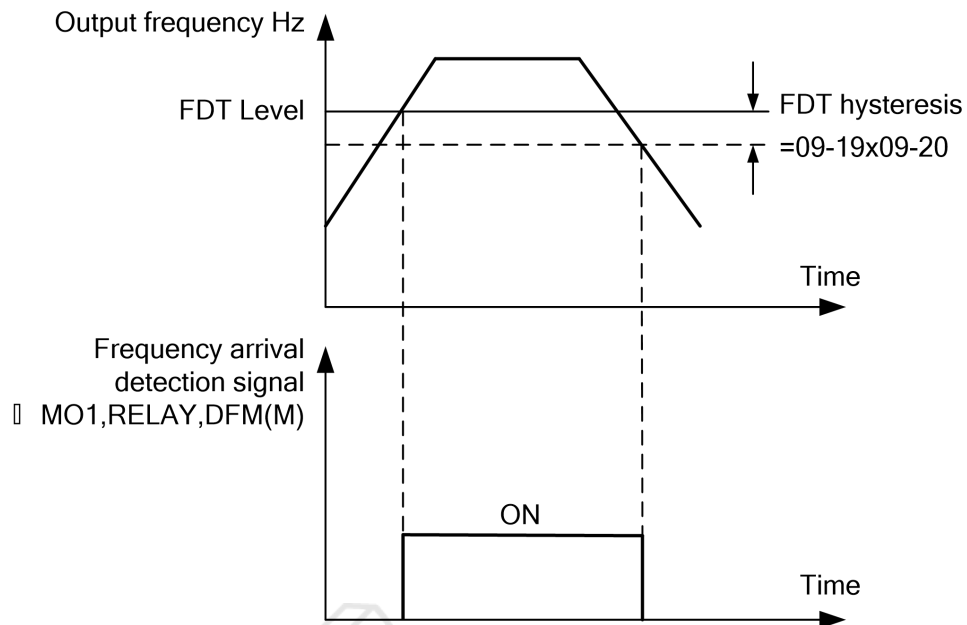

Figure 5-17 Schematic diagram of FDT level

09-21	Frequency reach detection width	↗	Factory setting	0.0%
	Setting range	0.00~100%(Max frequency)		

When the running frequency of the inverter is within a certain range of the target frequency, the multi-function output terminal (function 4) of the inverter outputs an ON signal.

This parameter is used to set the detection range of frequency arrival. This parameter is a percentage relative to the maximum frequency. Figure 5-18 is a schematic diagram of frequency arrival.

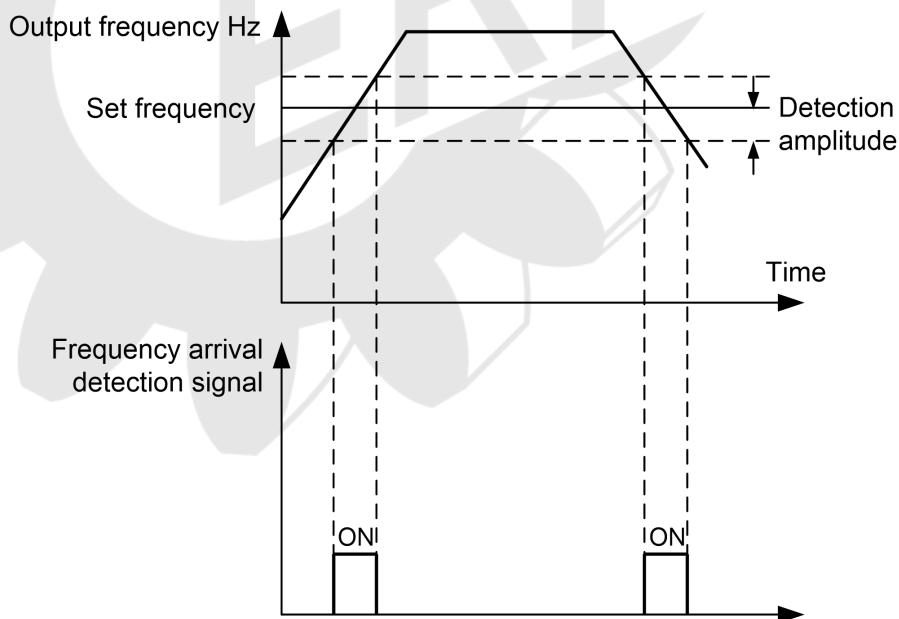

Figure 5-18 Schematic diagram of the frequency arrival detection amplitude

09-22	Whether the jump frequency is effective during acceleration and deceleration	↗	Factory setting	0
	Setting range	0	Invalid	
		1	Valid	

When the setting is valid, when the operating frequency is within the range of the skip frequency, the actual operating frequency will skip the boundary of the set skip frequency. As shown in Figure 5-19.

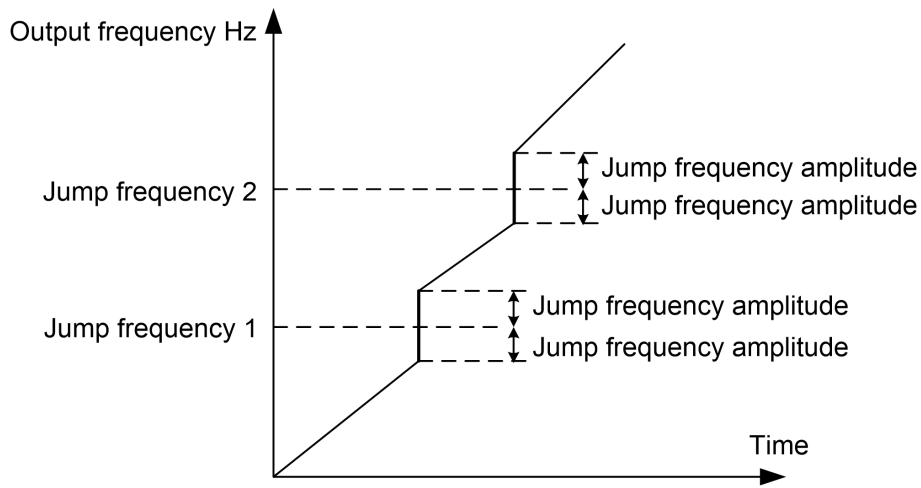

Figure 5-19 Effective schematic diagram of jump frequency during acceleration and deceleration

09-25	Switching frequency point between acceleration time 1 and acceleration time 2		↗	Factory setting	0.00Hz
	Setting range	0.00Hz~Max frequency			
09-26	Switching frequency point between deceleration time 1 and deceleration time 2		↗	Factory setting	0.00Hz
	Setting range	0.00Hz~Max frequency			

During the operation of the inverter, different acceleration and deceleration times can be selected according to the operating frequency range instead of the MI terminal.

Figure 5-20 is a schematic diagram of acceleration/deceleration time switching. During acceleration, if the operating frequency is less than 09-25, select acceleration time 2; if the operating frequency is greater than 09-25, select acceleration time 1.

During deceleration, if the operating frequency is greater than 09-26, select deceleration time 1, if the operating frequency is less than 09-26, select deceleration time 2.

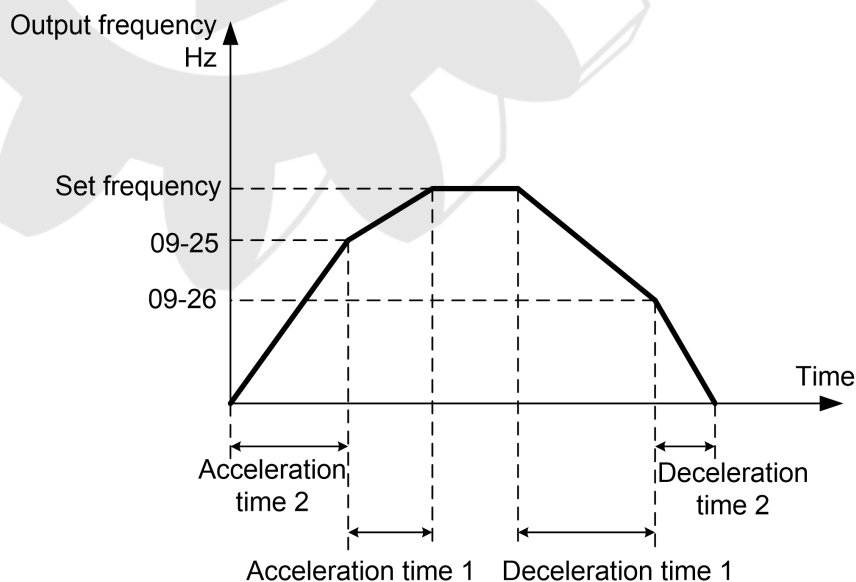

Figure 5-20 Acceleration and deceleration time switching diagram

09-27	Terminal jogging priority		↗	Factory setting	0
	Setting range	0	Invalid		
		1	Valid		

This parameter can set the priority of the terminal jog command to the highest.

When the terminal jog priority is effective, if the terminal jog command appears during the operation, the inverter will switch to the terminal jog running state.

09-28	Frequency detection value(FDT2)	↗	Factory setting	50.00Hz
	Setting range	0.00Hz~Max frequency		
09-29	Frequency detection hysteresis(FDT2)	↗	Factory setting	5.0%
	Setting range	0.0%~100.0%(FDT2 Level)		

The frequency detection function is exactly the same as the function of FDT1. Please refer to the relevant description of FDT1, namely the description of parameters 09-19 and 09-20.

09-30	Arbitrary arrival frequency detection value 1	↗	Factory setting	50.00Hz
	Setting range	0.00Hz~Max frequency		
09-31	Arbitrary arrival frequency detection width 1	↗	Factory setting	0.0%
	Setting range	0.0%~100.0%(Max frequency)		
09-32	Arbitrary arrival frequency detection value 2	↗	Factory setting	50.00Hz
	Setting range	0.00Hz~Max frequency		
09-33	Arbitrary arrival frequency detection width 2	↗	Factory setting	0.0%
	Setting range	0.0%~100.0%(Max frequency)		

When the output frequency is within the range of the positive and negative detection amplitude of any detected frequency, the multi-function output terminal (function 26/27) outputs an ON signal.

S3100A provides two sets of arbitrary arrival frequency detection parameters, set frequency value and frequency detection range respectively. Figure 5-21 is a schematic diagram of this function.

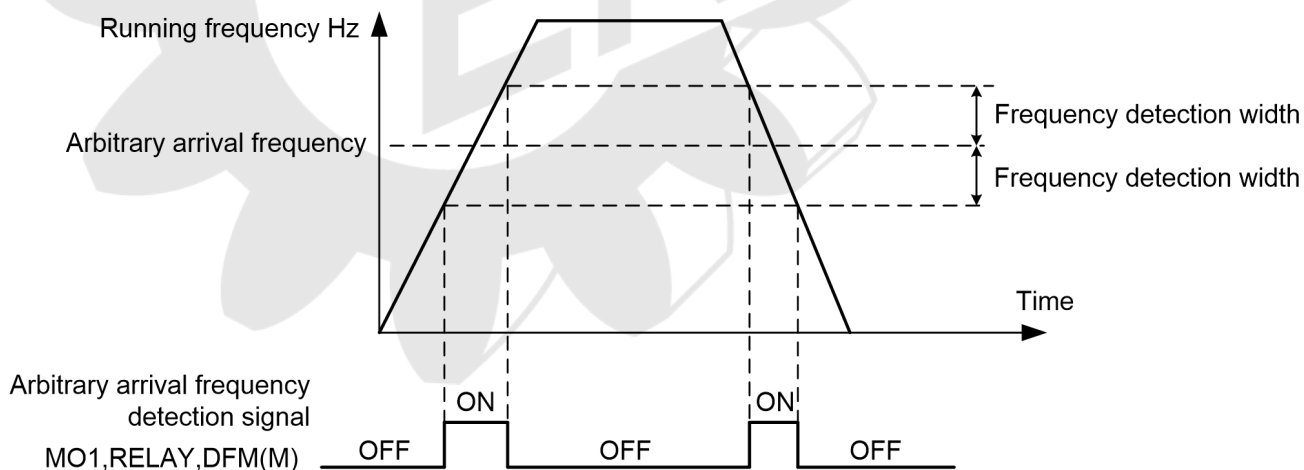

Figure 5-21 Schematic diagram of arbitrary arrival frequency detection

09-34	Zero current detection level	↗	Factory setting	5.0%
	Setting range	0.0%~300.0% (100.0% corresponds to the rated current of the motor)		
09-35	Zero current detection delay time	↗	Factory setting	0.10s
	Setting range	0.01s~600.00s		

When the output current of the inverter is less than or equal to the zero current detection level and the duration exceeds the zero current detection delay time, the multi-function output terminal (function 34) of the inverter outputs an ON signal. Figure 5-22 is a schematic diagram of zero current detection.

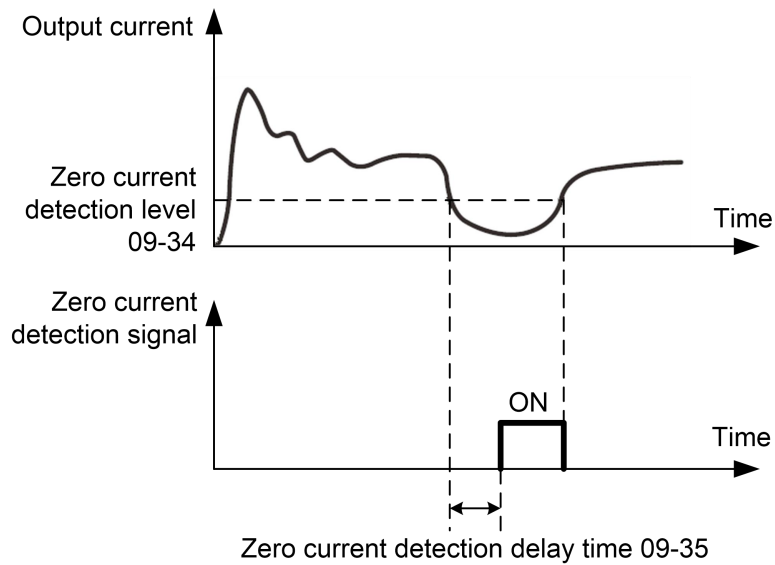

Figure 5-22 Schematic diagram of zero current detection

09-36	Output current limit		↗	Factory setting	200.0%
	Setting range	0.0%(No detection) 0.1%~300.0%(motor rated current)			
09-37	Output overcurrent detection delay time		↗	Factory setting	0.00s
	Setting range	0.00s~600.00s			

When the output current of the inverter is greater than or exceeds the limit detection point and the duration exceeds the software overcurrent detection delay time, the inverter's multi-function output terminal (function 36) outputs an ON signal.

Figure 5-23 is a schematic diagram of the output overcurrent detection.

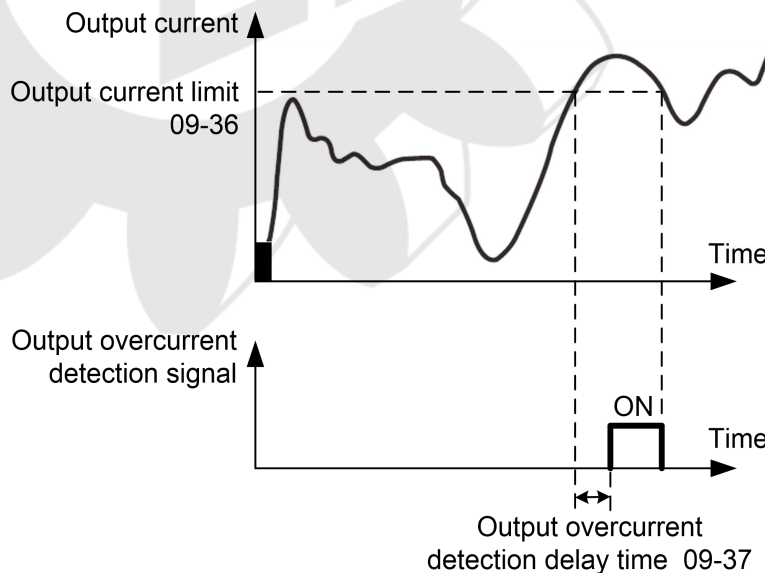

Figure 5-23 Schematic diagram of output overcurrent detection

09-38	Arbitrary arrival current 1		↗	Factory setting	100.0%
	Setting range	0.0%~300.0%(motor rated current)			
09-39	Arbitrary arrival current 1 width		↗	Factory setting	0.0%
	Setting range	0.0%~300.0%(motor rated current)			

09-40	Arbitrary arrival current 2		↗	Factory setting	100.0%
	Setting range	0.0%~300.0%(motor rated current)			
09-41	Arbitrary arrival current 2 width		↗	Factory setting	0.0%
	Setting range	0.0%~300.0%(motor rated current)			

When the inverter output current is within any positive or negative detection width of the current, the inverter multi-function output terminal Terminal (function 28/29) outputs ON signal.

S3100A provides two sets of arbitrary current arrival and detection width parameters. Figure 5-24 is a schematic diagram of the function.

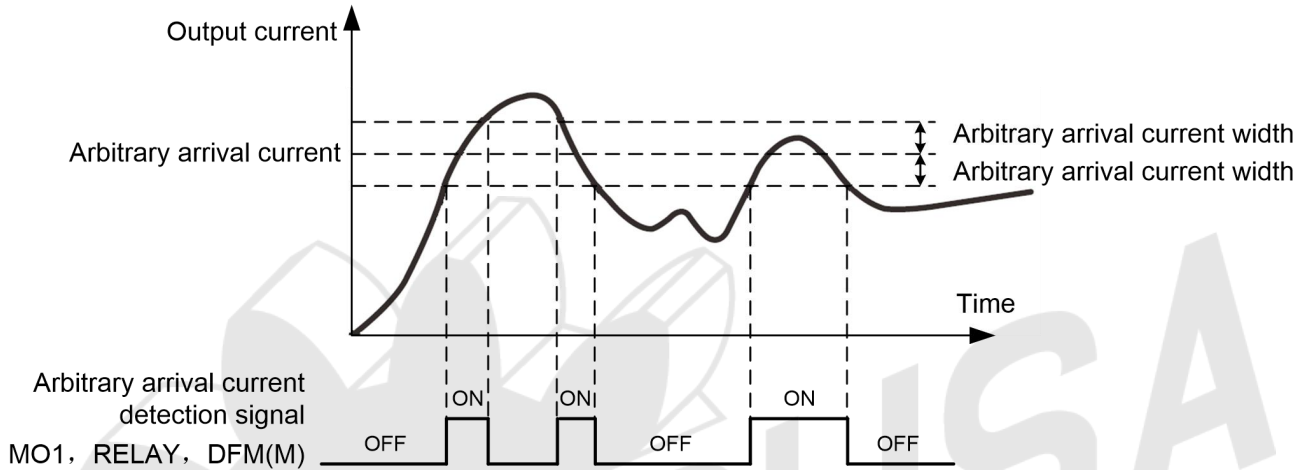

Figure 5-24 Schematic diagram of arbitrary arrival current detection

09-42	Timing function selection			Factory setting	0
	Setting range	0	Invalid		
		1	Valid		

09-43	Timed running time selection			Factory setting	0
	Setting range	0	09-44 Setting		
		1	AVI1		
		2	AVI2/ACI		
		3	Reserved		
	Analog input range 100% corresponds to 09-44				

09-44	Timed running time			Factory setting	0.0Min
	Setting range	0.0Min~6500.0Min			

09-42 when the timing function selection is valid, the inverter starts timing when it starts, and when the set timing operation time is reached, the inverter automatically stops, and the multi-function output terminal (function 30) outputs an ON signal.

Every time the inverter starts, it starts counting from 0, and the remaining running time can be checked through 99-20. The scheduled running time is set by 09-43 and 09-44, and the time unit is minutes.

09-45	Lower limit of AVI1 input voltage protection value		↗	Factory setting	3.10V
	Setting range	0.00V~09-46			

09-46	Upper limit of AVI1 input voltage protection value	↗	Factory setting	6.80V
	Setting range	09-45~11.00V		

When the value of the analog input AVI1 is greater than 09-46, or the AVI1 input is less than 09-45, the inverter's multi-function output terminal (function 31) outputs an ON signal, which is used to indicate whether the AVI1 input voltage is within the set range.

09-47	Module temperature reached	↗	Factory setting	75°C
	Setting range	0°C~100°C		

When the temperature of the inverter radiator reaches this temperature, the multi-function output terminal (function 35) of the inverter outputs an ON signal.

09-48	Cooling fan control		Factory setting	0
	Setting range	0	Fans run during operation	
		1	The fan keeps running	

It is used to select the operation mode of the cooling fan. When it is set to 0, the fan runs in the running state. If the temperature of the radiator is higher than 40 degrees in the stopped state, the fan runs.

When selected as 1, the fan keeps running after power on.

09-49	Wake frequency	↗	Factory setting	0.00Hz
	Setting range	Sleep frequency (09-51) ~ max frequency (00-03)		
09-50	Wake delay time	↗	Factory setting	0s
	Setting range	0s~65000s		
09-51	Sleep frequency	↗	Factory setting	0.00Hz
	Setting range	0.00Hz~Wake frequency(09-49)		
09-52	Sleep delay time	↗	Factory setting	0s
	Setting range	0s~65000s		

This group of parameters is used to implement sleep and wake-up functions in water supply applications.

During the operation of the inverter, when the set frequency is less than or equal to the sleep frequency of 09-51, after the delay time of 09-52, the inverter enters the sleep state and automatically stops.

If the inverter is in sleep state and the current running command is valid, when the set frequency is greater than or equal to the wake-up frequency of 09-49, the inverter will start after a delay time of 09-50.

In general, please set the wake-up frequency to be greater than or equal to the sleep frequency. If the wake-up frequency and sleep frequency are both set to 0.00Hz, the sleep and wake-up functions are invalid.

When the sleep function is enabled, if the frequency source uses PID, whether the PID operation in the sleep state is affected by the parameter 10-28. At this time, it is necessary to select PID calculation when the machine is stopped (10-28=1).

09-53	Arrival time setting for this run		Factory setting	0.0Min
	Setting range	0.0Min~6500.0Min		

When the running time of this startup reaches this time, the inverter multi-function output terminal Terminal (function 40) outputs ON signal.

10 PID Control Parameters

PID control is a common method of process control. By performing proportional, integral, and differential operations on the difference between the controlled variable feedback signal and the target signal, and by adjusting the output frequency of the inverter, a closed-loop system is formed to stabilize the controlled variable at Target value. It is suitable for process control occasions such as flow control, pressure control and temperature control. Figure 5-25 shows the principle block diagram of the process PID control.

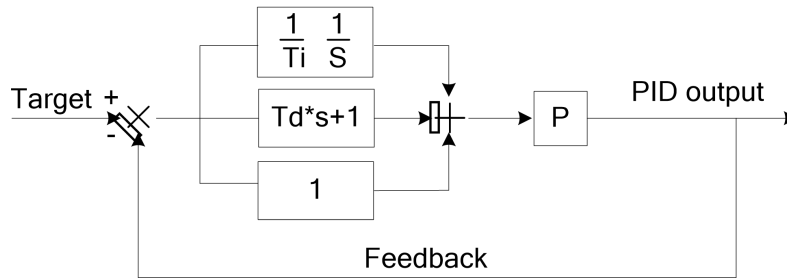

Figure 5-25 Principle block diagram of PID control

10-00	PID given source		↗	Factory setting	0
	Setting range	0	10-01 Setting		
		1	AVI1		
		2	AVI2/ACI		
		3	Reserved		
		4	PULSE setting (MI5)		
		5	Communication setting		
		6	Multi-step speed command given		
10-01	PID data given		↗	Factory setting	50.0%
	Setting range	0.0%~100.0%			

This parameter is used to select the given channel for the target quantity of the process PID.

The process PID setting target value is a relative value, and the setting range is 0.0%~100.0%. Similarly, the feedback quantity of PID is also a relative quantity. The role of PID is to make these two relative quantities the same.

10-02	PID feedback source		↗	Factory setting	0
	Setting range	0	AVI1		
		1	AVI2/ACI		
		2	Reserved		
		3	AVI1 – AVI2/ACI		
		4	PULSE setting (MI5)		
		5	Communication setting		
		6	AVI1+AVI2/ACI		
		7	MAX(AVI1 , AVI2/ACI)		
		8	MIN (AVI1 , AVI2/ACI)		

This parameter is used to select the feedback signal channel of the process PID.

The feedback value of the process PID is also a relative value, and the setting range is 0.0%~100.0%.

10-03	PID action direction		↗	Factory setting	0
	Setting range	0	Positive action		
		1	Reaction		

Positive effect: When the PID feedback signal is less than the given amount, the output frequency of the inverter rises. Such as tension control in winding.

Reverse effect: When the PID feedback signal is less than the given amount, the output frequency of the inverter decreases. Such as unwinding tension control occasions.

This function is affected by the multi-function terminal "PID reverse direction" (function 35), which needs attention during use.

10-04	PID Given feedback range		↗	Factory setting	1000
	Setting range	0~65535			

PID given feedback range is a dimensionless unit, used for PID given display 99-15 and PID feedback display 99-16.

The relative value of PID given feedback is 100.0%, corresponding to the given feedback range 10-04.

For example, if 10-04 is set to 2000, when PID setting is 100.0%, PID setting displays 99-15 to 2000.

10-05	Proportional gain Kp1		↗	Factory setting	20.0
	Setting range	0.0~999.9			
10-06	Integration time Ti1		↗	Factory setting	2.00s
	Setting range	0.00s~10.00s			
10-07	Differential time Td1		↗	Factory setting	0.000s
	Setting range	0.000s~10.000s			

Proportional gain Kp1:

Determines the adjustment intensity of the entire PID regulator. The greater the Kp1, the greater the adjustment intensity. The parameter 100.0 indicates that when the deviation between the PID feedback amount and the given amount is 100.0%, the adjustment range of the PID regulator for the output frequency command is the maximum frequency.

Integration time Ti1:

Determine the intensity of PID regulator integral adjustment. The shorter the integration time, the greater the adjustment intensity. The integration time refers to the amount of PID feedback, when the deviation from the given amount is 100.0%, the integral regulator continuously adjusts after this time, and the adjustment amount reaches the maximum frequency, when the integral time is 0, there is a deviation between the given quantity and the feedback quantity of the PID, and the adjustment quantity of the integral regulator is 0.

Differential time Td1:

Determines the strength of the PID regulator to adjust the deviation rate of change. The longer the differential time, the greater the adjustment intensity. Differential time refers to

The feed rate changes by 100.0% within this time, and the adjustment amount of the differential regulator is the maximum frequency.

10-08	PID reverse cutoff frequency		↗	Factory setting	0.00Hz
	Setting range	0.00~Max frequency			

In some applications, only when the PID output frequency is negative (that is, the inverter reverses) can the PID control the given amount and the feedback amount to the same state, but in some occasions, excessive reverse frequency is not allowed. 10-08 to set the upper limit of reverse frequency.

10-09	PID deviation limit		↗	Factory setting	0.0%
	Setting range	0.0%~100.0%			

When the deviation between the PID given amount and the feedback amount is less than 10-09, the PID stops adjusting. In this way, the output frequency is stable when the deviation between the reference and feedback is small, which is very effective for some closed-loop control occasions.

10-10	PID differential limiting		↗	Factory setting	0.50%
	Setting range	0.00%~100.00%			

In PID regulators, the role of differential is relatively sensitive, and it is easy to cause system oscillation. Therefore, the role of PID differential is generally limited to a small range. 10-10 is used to set the range of PID differential output.

10-11	PID given change time		↗	Factory setting	0.00s
	Setting range	0.00s~650.00s			

PID given change time refers to the time required for PID given value to change from 0.0% to 100.0%.

When the PID setting changes, the PID setting value changes linearly according to the given change time, which reduces the adverse effect of the mutation on the system.

10-12	PID feedback filter time		↗	Factory setting	0.00s
	Setting range	0.00s~60.00s			
10-13	PID output filter time		↗	Factory setting	100.0s
	Setting range	0.0s~600.0s			

10-12 is to filter the PID feedback value. This filtering is helpful to reduce the influence of the feedback value, but it will affect the response performance of the process closed-loop system.

10-13 is to filter the PID output frequency. This filtering will reduce the sudden change of the inverter output frequency, but it will also affect the response performance of the process control.

10-14	Reserved		↗	Factory setting	-
--------------	----------	--	---	-----------------	---

10-15	Proportional gain Kp2		↗	Factory setting	20.0
	Setting range	0.0~999.9			

10-16	Integration time Ti2		↗	Factory setting	2.00s
	Setting range	0.00s~10.00s			

10-17	Differential time Td2		↗	Factory setting	0.000s
	Setting range	0.000s~10.000s			

10-18	PID parameter switching conditions		↗	Factory setting	0
	Setting range	0	No switch		
		1	Switch via MI terminal		
		2	Automatically switch according to deviation		
		3	Automatically switch according to operating frequency		

10-19	PID parameter switching deviation 1		↗	Factory setting	20.0%
	Setting range	0.0%~10-20			
10-20	PID parameter switching deviation 2		↗	Factory setting	80.0%
	Setting range	10-19~100.0%			

In some applications, a group of PID parameters cannot meet the requirements of the entire operation process, and different PID parameters need to be used in different situations.

This group of parameters is used to switch between two groups of PID parameters. The setting method of the parameters 10-15~10-17 of the regulator is similar to the parameters 10-05~10-07.

The two sets of PID parameters can be switched through the multi-function input MI terminal I, and can also be automatically switched according to the deviation of PID.

When switching through the multi-function MI terminal I, the function selection I of the multi-function terminal I should be set to function 43 (PID parameter switching terminal I), when the terminal I is invalid, select the parameter group 1 (10-05~10-07), When terminal I is valid, select parameter group 2 (10-15~10-17).

When the automatic switching is selected, the absolute value of the deviation between the given and feedback is less than the PID parameter switching deviation 1 10-19, PID parameter selection parameter group 1. When the absolute value of the deviation between the reference and feedback is greater than the PID switching deviation 2 (10-20), PID parameter selection selects parameter group 2. When the deviation between reference and feedback is between switching deviation 1 and switching deviation 2, the PID parameters are the linear interpolation values of the two groups of PID parameters, as shown in Figure 5-26.

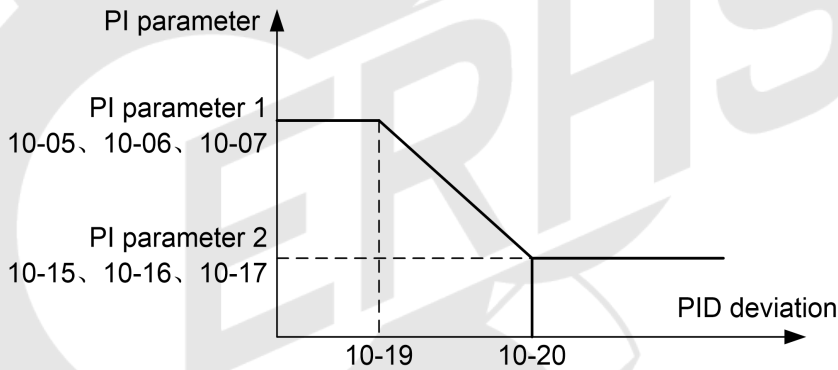

Figure 5-26 PID parameter switching

10-21	PID Initial value		↗	Factory setting	0.0%
	Setting range	0.0%~100.0%			
10-22	PID initial value hold time		↗	Factory setting	0.00s
	Setting range	0.00s~650.00s			

When the inverter starts, the PID output is fixed at the initial PID value of 10-21, and the PID will start the closed-loop adjustment operation only after the initial PID holding time of 10-22.

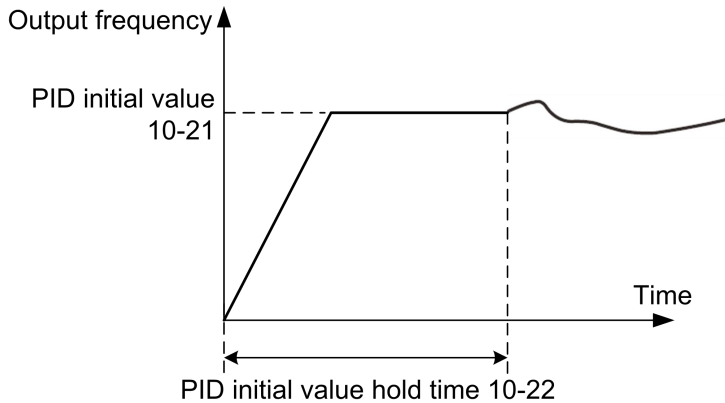

Figure 5-27 Schematic diagram of PID initial value function

This function is used to limit the difference between two beats (2ms/beat) of PID output, so as to restrain the PID output from changing too fast, and make the operation of the inverter tend to be stable.

10-23	Reserved	↗	Factory setting	
10-24	Reserved	↗	Factory setting	

10-25	PID feedback upper limit detection		↗	Factory setting	0.0%
	Setting range	0.0%: No judgment 0.1%~100.0%			

10-26	PID feedback lower limit detection		↗	Factory setting	0.0%
	Setting range	0.0%: No judgment 0.1%~100.0%			
10-27	PID feedback loss detection time		↗	Factory setting	0.0s
	Setting range	0.0s~20.0s			

This parameter can detect whether the PID feedback line is missing.

When the PID feedback amount is less than the feedback loss detection value 10-26, and the duration exceeds the PID feedback loss detection time 10-27, the inverter alarms the fault PIDE, and handles it according to the selected fault handling method.

10-28	PID Shutdown calculation		↗	Factory setting	0
	Setting range	0	No operation during shutdown		
		1	Operation at shutdown		

It is used to select whether PID continues to operate under PID stop status. In general applications, PID should stop calculation in the stop state.

11 Fault and Protection Parameters

11-00	Motor overload protection selection		↗	Factory setting	1
	Setting range	0	Disabled		
		1	Enabled		
11-01	Motor overload protection gain		↗	Factory setting	1
	Setting range	0.20~10.00			

0: No protection, no motor overload protection feature (use with caution), at this time, the inverter has no overload protection for the load motor.

1: At this time, the inverter judges whether the motor is overloaded according to the inverse time limit curve of the motor overload protection. The inverse time limit curve of motor overload protection is: $195\% \times (11-01) \times \text{motor rated current}$, which will alarm the motor overload fault for 1 minute; $150\% \times (11-01) \times \text{motor rated current}$, which lasts 5 minutes Then alarm motor overload.

The user sets the value of 11-01 according to the actual overload capacity of the motor. If the setting is too large, the motor may be damaged due to overheating and the inverter may not alarm in time!

11-02	Motor overload pre-warning coefficient	↗	Factory setting	80%
	Setting range	50%~100%		

This function is used to output an early warning signal to the control system through the multi-function output terminal before the motor overload protection. The early warning function can set how much early warning is given before the motor overload protection. The larger the value, the smaller the early warning advance.

When the cumulative output current of the inverter is greater than the product of the overload inverse time curve and 11-02, the inverter's multi-function output terminal (function 7) outputs the "motor overload pre-alarm" ON signal.

11-03	Selection of short-circuit protection to ground	↗	Factory setting	01
	Setting range	Units: short circuit protection on power-on to ground Tens place: short circuit protection to ground before operation		
		0	Invalid	
		1	Valid	

Select whether to detect the short circuit fault of the motor when the inverter is powered on.

If this function is valid, there will be voltage output from the UVW terminal of the inverter within a period of time after power-on.

11-08	Brake initial voltage	↗	Factory setting	220V:370V 380V:690V
	Setting range	350.0~800.0V		

11-09	Fault automatic reset times	↗	Factory setting	0
	Setting range	0~30		

When the inverter selects automatic fault reset, it is used to set the number of automatic resets. After this number of times, the inverter remains in a fault state and requires manual intervention.

11-10	Action selection of fault multi-function output terminal during fault automatic reset	↗	Factory setting	0
	Setting range	0	No action	
		1	Action	

If the inverter is equipped with a fault automatic reset function, whether the multi-function terminals are activated during the fault automatic reset can be set via 11-10.

11-11	Fault automatic reset interval time	↗	Factory setting	6.0s
	Setting range	0.1s~100.0s		

Waiting time from inverter fault alarm to automatic fault reset.

11-12	Input phase loss protection selection	↗	Factory setting	1
	Setting range	0	Disabled	
		1	Output alarm when the running output is 40% of the motor rated current	
		2	Output alarm when running with phase loss	

Choose whether to protect the input phase loss.

S3100A frequency converter 7.5kW, G type and above power, only have input phase loss protection function, 7.5kW, P type power and below power, no matter 11-12 is set to 0 or 1, there is no input phase loss protection function.

11-13	Output phase loss protection selection	↗	Factory setting	07
	Setting range	Bit:Output phase loss protection setting		
		0	Forbid	
		1~8	Output phase loss check level multiple	
		Tens place: output phase loss protection before running		
		0	Disabled	
		1	Enabled	

Choose whether to protect the output phase loss. The smaller the setting of the output phase loss check level multiple for each bit, the more sensitive the output phase loss check will be. Setting it too small may cause false alarms. The minimum limit for ordinary models is 5 times.

11-14	First failure type	Factory setting	-
11-15	Second failure type	Factory setting	-
11-16	Third (latest) fault type	Factory setting	-

Record the last three fault types of the inverter,0 is no fault. For the cause and solution of the fault, please refer to the relevant instructions in Chapter 6.

11-17	Frequency at the third failure	Frequency at latest failure																				
11-18	Current at the third fault	Current at latest fault																				
11-19	Bus voltage at the third fault	Bus voltage at the latest fault																				
11-20	Input terminal status at the third fault	<p>The state of the digital input terminal during the latest failure, the order is:</p> <table border="1"> <tr> <td>BIT9</td><td>BIT8</td><td>BIT7</td><td>BIT6</td><td>BIT5</td><td>BIT4</td><td>BIT3</td><td>BIT2</td><td>BIT1</td><td>BIT0</td> </tr> <tr> <td>MI0</td><td>MI9</td><td>MI8</td><td>MI7</td><td>MI6</td><td>MI5</td><td>MI4</td><td>MI3</td><td>MI2</td><td>MI1</td> </tr> </table> <p>When the input terminal is ON, the corresponding secondary system bit is 1,OFF is 0, and all MI status is converted to decimal number display.</p>	BIT9	BIT8	BIT7	BIT6	BIT5	BIT4	BIT3	BIT2	BIT1	BIT0	MI0	MI9	MI8	MI7	MI6	MI5	MI4	MI3	MI2	MI1
BIT9	BIT8	BIT7	BIT6	BIT5	BIT4	BIT3	BIT2	BIT1	BIT0													
MI0	MI9	MI8	MI7	MI6	MI5	MI4	MI3	MI2	MI1													
11-21	Output terminal status at the third fault	<p>The state of all output terminals during the latest fault,the order is</p> <table border="1"> <tr> <td>BIT4</td><td>BIT3</td><td>BIT2</td><td>BIT1</td><td>BIT0</td> </tr> <tr> <td>MO2</td><td>MO1</td><td>REL2</td><td>REL1</td><td>DFM(P)</td> </tr> </table> <p>When the input terminal is ON, the corresponding secondary system bit is 1, OFF is 0, and all MI status is converted to decimal number display.</p>	BIT4	BIT3	BIT2	BIT1	BIT0	MO2	MO1	REL2	REL1	DFM(P)										
BIT4	BIT3	BIT2	BIT1	BIT0																		
MO2	MO1	REL2	REL1	DFM(P)																		
11-22	Inverter status at the third fault	Reserved																				
11-23	Power-on time at the third fault	The current power-on time when the latest fault occurred																				
11-24	Running time at the third failure	Current running time at the time of the latest failure																				
11-27	Frequency at second failure	The same to 11-17~11-24																				
11-28	Current at second fault																					
11-29	Bus voltage at the second fault																					

11-30	Input terminal status at the second fault	The same to 11-17~11-24
11-31	Output terminal status at the second fault	
11-32	Inverter status at the second fault	
11-33	Power-on time at the second fault	
11-34	Running time on second failure	
11-37	Frequency at first failure	
11-38	Current at first fault	
11-39	Bus voltage at first fault	
11-40	Input terminal status at the first fault	
11-41	Output terminal status at the first fault	
11-42	Inverter status at first fault	
11-43	Power-on time at first failure	
11-44	Operating time at first failure	

11-47	Fault protection action selection1	↗	Factory setting	0
Setting range	Single digit	Motor overload(OL1)		
	0	Coast to stop		
	1	Stop according to the stop mode		
	2	Continue to run		
	Tens digital	Input phase loss(SPI)(Same bit)		
	Hundreds digital	Output phase loss(SPo)(Same bit)		
	Thousands digital	External fault(EF)(Same bit)		
	Ten thousands digital	Communication error(CE)(Same bit)		

11-48	Fault protection action selection 2	↗	Factory setting	0
Setting range	Single digit	Reserved		
	Tens digital	EEPROM read write fault(EEP)		
	0	Coast to stop		
	1	Stop according to the stop mode		
	Hundreds digital	Reserved		
	Thousands digital	Reserved		
	Ten thousands digital	Operating time arrival (Eond) (same as 11-47 digits)		

11-49	Fault protection action selection 3		↗	Factory setting	0
	Setting range	Single digit	Reserved		
		Tens digital	Reserved		
		Hundreds digital	Power-on time arrival (EIND) (same as 11-47 digits)		
		Thousands digital	Lost load(oLL)		
		0	Coast to stop		
		1	Stop according to the stop mode		
		2	Decelerate to 7% of the rated frequency of the motor and continue to run. If the load is not lost, it will automatically return to the set frequency.		
		Ten thousands digital	PID feedback lost during operation (PIDE) (same as 11-47 bits)		
11-50	Fault protection action selection 4		↗	Factory setting	
	Setting range	Reserved			

When "free stop" is selected, the inverter displays the fault code and directly stops.

When "Stop by Stop Mode" is selected: The inverter displays a fault and stops according to the stop mode.

When "Continue running" is selected: The inverter displays a fault and the running frequency continues to run at the selected frequency of 11-54.

11-54	Continue running frequency selection in case of failure		↗	Factory setting	0
	Setting range	0	Run at current operating frequency		
		1	Run at set frequency		
		2	Run at upper limit frequency		
		3	Run at the lower limit frequency		
		4	Run at abnormal standby frequency		
11-55	Abnormal standby frequency		↗	Factory setting	100.0%
	Setting range	0.0%~100.0%(100.0% corresponds to the maximum frequency 00-03)			

When a fault occurs during the operation of the inverter, and the processing method of the fault is set to continue running, the inverter displays the fault and continues to run at the selected frequency of 11-54. When the abnormal standby frequency is selected for operation, the value set in 11-55 is a percentage relative to the maximum frequency.

11-56	Reserved		Factory setting	
11-57	Reserved		Factory setting	
11-58	Reserved		Factory setting	

11-59	Instantaneous power failure action selection		Factory setting	0
	Setting range	0	Invalid	
		1	Deceleration	
		2	Decelerate to stop	

11-60	Instantaneous power failure action pause judgment voltage			Factory setting	85%
	Setting range	80~100%			
11-61	Judgment time of instantaneous power failure voltage rise			Factory setting	0.5s
	Setting range	0.0s~100.0s			
11-62	Judgment voltage of instantaneous power failure			Factory setting	80%
	Setting range	60%~100%(Standard bus Voltage)			

Refers to the moment when there is a power failure or the voltage drops suddenly, the inverter reduces the output speed, so that the load feedback energy maintains the inverter DC bus voltage, so that the inverter continues to run.

If 11-59=1, the inverter decelerates when there is an instantaneous power failure or a sudden drop in voltage, and when the bus voltage returns to normal, the inverter normally accelerates to the set frequency. The basis for judging the return of the bus voltage to normal is that the bus voltage is normal and the duration exceeds the set time of 11-61.

If 11-59=2, during an instantaneous power failure or a sudden drop in voltage, the inverter decelerates until it stops.

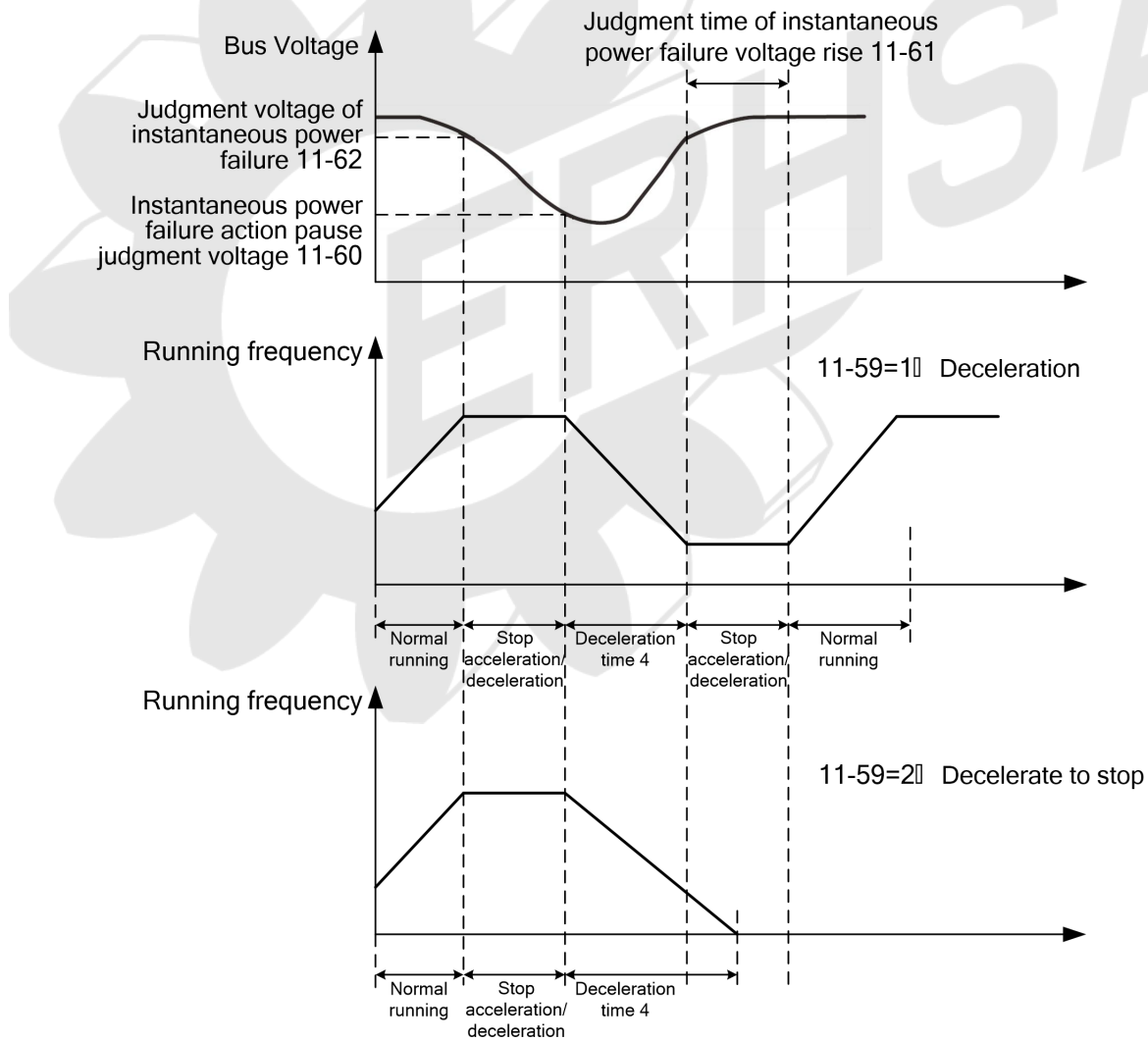

Figure 5-28 Schematic diagram of instantaneous power failure

11-63	Lost load protection options		↗	Factory setting	0
	Setting range	0	Invalid		
		1	Valid		

11-64	Lost load detection level	↗	Factory setting	10.0%
	Setting range	0.0~100.0%		
11-65	Lost load detection time	↗	Factory setting	1.0s
	Setting range	0.0s~60.0s		

If the off-load protection function is effective, when the inverter output current is less than the off-load detection level 11-64, and the duration is greater than the off-load detection time 11-65, the inverter output frequency is automatically reduced to 7% of the rated frequency. During the load protection period, if the load is restored, the inverter automatically resumes to run at the set frequency.

11-66	Load shedding frequency setting	↗	Factory setting	100.0%
	Setting range	Above this frequency value, 0~102.4% setting load shedding is valid		

Above this frequency value, setting load shedding is valid .

11-67	Reserved		Factory setting	-
11-68	Reserved		Factory setting	-
11-69	Reserved		Factory setting	-
11-70	Reserved		Factory setting	-

11-71	Instant stop but non-stop proportional gain	↗	Factory setting	40
	Setting range	0~100		
11-72	Instant stop but non-stop integral coefficient	↗	Factory setting	30
	Setting range	0~100		

PI control parameters for continuous operation after instantaneous power outage.

Adjusting the appeal parameters can adjust the dynamic response characteristics of non-stop action after instantaneous power outage. The integral coefficient is not the integral time, but directly used as the integral gain.

11-73	Action deceleration time of Instant stop but non-stop		Factory setting	20.0s
	Setting range	0~300.0s		

11-74	Level of low-voltage emergency stop	↗	Factory setting	0.0V
	Setting range	0.0V~6553.5V(0.0 invalid)		

11-75	OL3 level	↗	Factory setting	100%
	Setting range	0%~100%		
11-76	OL3 time	↗	Factory setting	0.00s
	Setting range	0.00s~650.00s		

11-79	Reserved		Factory setting	-
11-80	Reserved		Factory setting	-

12 Serial Communication Parameters

12-00	Local address	↗	Factory setting	1
	Setting range	1~247, 0 is broadcast address		

When the local address is set to 0, it is the broadcast address to realize the broadcast function of the host computer.

The local address is unique (except broadcast address), which is the basis for the point-to-point communication between the host computer and the inverter.

12-01	Baud rate	↗	Factory setting	0005
	Setting range	Single digit	MODUBS Baud rate	
		0	300BPS	
		1	600BPS	
		2	1200BPS	
		3	2400BPS	
		4	4800BPS	
		5	9600BPS	
		6	19200BPS	
		7	38400BPS	
		8	57600BPS	
	9	115200BPS		

This parameter is used to set the data transmission rate between the host computer and the inverter. Note that the baud rate set by the host computer and the inverter must be the same; otherwise, communication cannot be performed. The higher the baud rate, the faster the communication speed.

12-02	Data format	↗	Factory setting	0
	Setting range	0	No checking(8-N-1)	
		1	Even parity checking(8-E-1)	
		2	Odd parity checking(8-O-1)	
		3	No checking(8-N-2)	

The host computer must coincide with the data format set by inverter, or communication can't be operated.

12-03	Communication response delay	↗	Factory setting	2
	Setting range	0~20ms		
		Hundreds digit:		
		1	have response	
		2	have response of write	
		3	no response of read and write	

Communication response delay refers to the interval time from end of inverter data receiving to sending response data to host computer. If the response delay time is shorter than system processing time, the response delay is subject to system processing time. If the response delay time is longer than system processing time, the system has to delay after processing the data. And send data to the host computer until the delay time is reached.

12-04	Communication timeout	↗	Factory setting	0.0
	Setting range	0.0(invalid),0.1~60.0s		

When this function code is set as 0.0s, the parameter of communication overtime time is invalid.

When this function code is set as valid value, if the interval time between one communication and the next communication exceeds the time of communication overtime, the system will report communication error (CE).

Normally, this parameter is set as invalid value.setting this parameter in system of continuous communication can monitor the communication status.

12-05	Reserved	↗	Factory setting	
	Setting range			

12-06	Communication reading current resolution	↗	Factory setting	0
	Setting range	0	0.01A	
		1	0.1A	

It is used to determine the output unit of the current value when the communication reads the output current.

Modbus protocol

S3100A series inverters provide RS485 communication interface and support Modbus communication protocol. Users can realize centralized control through PC or PLC, set inverter running command, operating frequency, modify or read function code parameters, monitor inverter working status and fault information, etc.

Protocol content

The serial communication protocol defines the content and format of information transmitted in serial communication. These include: host polling and broadcasting; host encoding methods, including: function codes that require actions, transmission data, and error checking. The response of the slave also adopts the same structure, including: action confirmation, return data and error check. If the slave receives an error when receiving information, or cannot complete the action required by the master, it will organize a fault message as a response to the master.

Application method:

The frequency inverter can be connected to the "single master and multiple slave" control network with RS485 bus.

Bus structure:

(1) Interface method

RS485 hardware interface

(2) Transmission method

Asynchronous serial, half-duplex transmission mode.At the same time, only one master and slave can send data and the other can only receive data. In the process of serial asynchronous communication, data is sent frame by frame in the form of messages.

(3) Topology

Single-master multi-slave system.The setting range of the slave address is 1~247, and 0 is the broadcast communication address. The slave addresses in the network are all unique.

Protocol description:

The S3100A series inverter communication protocol is an asynchronous serial master-slave Modbus communication protocol. Only one device (host) in the network can establish the protocol (called "query/command"). Other devices (slave) can only respond to the "query/command" of the host by providing data, or make corresponding actions according to the "query/command" of the host. The master here refers to a personal computer (PC), industrial control equipment or programmable logic controller (PLC), etc., and the slave

refers to the S3100A inverter.

The master can not only communicate with a certain slave, but also broadcast information to all slaves. For the "query/command" of the separately accessed host, the slave must return a message (called a response). For the broadcast information sent by the host, the slave does not need to respond to the host.

Communication Frames Structure:

The Modbus protocol communication data format of S3100A series inverters uses RTU mode, and new frames always start with a silent transmission time of at least 3.5 bytes. On a network that calculates the transmission rate in baud rate, the transmission time of 3.5 bytes can be easily grasped. The data fields transmitted next are in order: slave address, operation command code, data and CRC check word, each field transmission byte is hexadecimal 0.9, A.F. Network equipment always monitors the activity of the communication bus. When receiving the first field (address information), each network device confirms the byte. As the transmission of the last byte is completed, there is a similar 3.5-byte transmission time interval, which is used to indicate the end of this frame. After that, a new frame transmission will start.

A message frame must be transmitted as a continuous data stream. If there is a pause time of more than 1.5 characters before the frame is completed, the receiving device will refresh the incomplete message and assume that the next byte is the address field of a new message. Similarly, if a new message starts after the previous message in less than 3.5 characters, the receiving device will consider it as a continuation of the previous message. This will cause an error because the value in the last CRC field cannot be correct.

RTU Frame format:

Frame header (START)	3.5 character time
Slave address (ADR)	Communication address:1~247
Command code (CMD)	03: Read slave parameters; 06: Write slave parameters
DATA(N-1)	Data content: Function code parameter address, function code parameter number, function code parameter value, etc.
DATA(N-2)	
.....	
DATA 0	
CRC CHK upper bite	Detection value: CRC value
CRC CHK lower bite	
END	3.5 character time

Command code and communication data description:

Command code: 03H, read N words (Word can read up to 12 words)

For example: the start address 0002 of the inverter with slave address 01 is continuously reading two consecutive values.

RTU host command information

ADR	01H
CMD	03H
Start address upper bit	00H
Start address lower bit	02H
Date number upper bit	00H
Date number lower bit	02H
CRC CHK lower bit	CRC CHK
CRC CHK upper bit	

RTU slave response information

ADR	01H
CMD	03H
Byte number	04H
Date address 0002H upper bit	00H
Date address 0002H lower bit	00H
Date address 0003H upper bit	00H
Date address 0003H lower bit	01H
CRC CHK Lower bit	CRC CHK
CRC CHK Upper bit	

Command code: 06H Write a word (Word)

For example: write 5000 (1388H) to the slave address 02H inverter 0003H address

Host command information

ADR	02H
CMD	06H
Data address upper bit	00H
Data address lower bit	03H
Data content upper bit	13H
Data content lower bit	88H
CRC CHK lower bit	CRC CHK
CRC CHK upper bit	

Slave response information

ADR	02H
CMD	06H
Data address upper bit	00H
Data address lower bit	03H
Data content upper bit	13H
Data content lower bit	88H
CRC CHK lower bit	CRC CHK
CRC CHK upper bit	

Checking method—CRC checking method:

In RTU frame format, the frame includes frame incorrect test field based on CRC computing. The CRC field detects the content of whole frames. The CRC field is 2 bytes and includes 16-binary. It is added to frame after being computed by transmission equipment. The receiving equipment recalculates the CRC which has received frames and compare it with values in the received CRC field. If the two CRC values are different, it indicates that there is transmission error received.

In CRC checking mode, it saves in 0xFFFF first, then uses a procedure and processes the continuous 8 more than bytes in frames together with current register. Only the 8-bit data in every character is available to CRC, the start bit, end bit and parity checking are all unavailable to it.

In CRC production course, every 8-bit character is different from the register content separately or (XOR). The result moves to the direction of lowest effective bit. And the highest bit is filled with 0. LSB is picked up to test. If LSB is 1, the register is different from the preset value alone. If LSB is 0, no actions. The whole process must be repeated 8 times. As the last bit (8th bit) is finished, the next 8-bit character is different from the present value of register again. The final value in register is the CRC value after all bytes in frame have been executed.

Here is a simple function of CRC algorithm for users' reference.

```

unsigned int crc_cal_value(unsigned char *data_value,unsigned char data_length)
{
    int i;
    unsigned int crc_value=0xffff;
    while(data_length--)
    {
        crc_value^=*data_value++;
        for(i=0;i<8;i++)
        {
            if(crc_value&0x0001)
                crc_value=(crc_value>>1)^0xa001;
            else
                crc_value=crc_value>>1;
        }
    }
    return(crc_value);
}

```

Definition of communication data address

It is the definition of communication data address, which is used to control inverter operation, obtain the state information and relative function parameters.

(1) Using method of function code parameter address

Using numbers of function code as parameters to correspond to the register address, which has to be converted to hexadecimal system. For example, the number of 05-10, the function code address expressed by hexadecimal system is 050A.

Ranges of high and low characters: high-bit character--00~0FH; low-bit character--00~FFH. (The parameter's change attribute refers to the parameter description)

In addition, the frequent storage of EEPROM will reduce its service life. For users, some function codes don't need to be stored in communication mode. The application requirement can be met only through altering values in RAM. This function can be realized as long as changing the highest bit of corresponding function code address from 0 to 1. For example, the function code 00-06 is not stored in the EEPROM, and the address at the highest position 1 is 8006H, which means that the address can only be written to RAM, not written to the EEPROM for saving, and the address can also be read directly.

(2) Communication command address:

Function description	Address definition	Description of data meaning	R/W characteristic
Communication control command	1000H	0001H: Forward running	W/R
		0002H: Reverse running	
		0003H: Forward jog	
		0004H: Reverse jog	
		0005H: Stop	
		0006H: Coast to stop	
		0007H: Fault reset	
		0008H: Reserved	
Inverter status	1001H	0001H: Forward running	R
		0002H: Reverse running	
		0003H: Inverter standby	
Communication setting value address	2000H	Communication setting value: range (-10000~10000) Note: communication setting value is the percentage of relative value, 10000 corresponds to 100.00%, and -10000 corresponds to -100.00%. For frequency dimension data, the percentage is the percentage of relative maximum frequency (00-03); for torque dimension data, the percentage is 02-07 (torque upper limit digital setting). About the PID feedback source, this percentage directly represents the value of the setting source.	W/R
Digital output terminal control	2001H	BIT0: MO1 output control BIT1: Reserved BIT2: Relay RA-RB-RC output control BIT3: Reserved BIT4: DFM(M) output control	W/R
Analog AFM output control	2002H	0~7FFF means 0%~100%	W/R

Function description	Address definition	Description of data meaning	R/W characteristic
Pulse DFM (P) output control	2004H	0~7FFF means 0%~100%	W/R
Address description of start/stop parameters	3000H	Running frequency	R
	3001H	Setting frequency	R
	3002H	Bus voltage	R
	3003H	Output voltage	R
	3004H	Output current	R
	3005H	Operation rotating speed	R
	3006H	Output power	R
	3007H	Output torque	R
	3008H	PID set value	R
	3009H	PID feedback value	R
	300AH	Terminal input flag state	R
	300BH	Terminal output flag state	R
	300CH	Analog quantity AVI1 value	R
	300DH	Analog quantity AVI2/ACI value	R
	300EH	Reserved	R
	300FH	Count value	R
	3010H	Length	R
	3011H	Load speed	R
3012H	Multi-speed and the current number of PLC	R	
3013H	PULSE input pulse frequency(unit: 1Hz)	R	
3014H	Communication setting value	R	
3015H	Reserved	R	
3016H	Main frequency X display	R	
3017H	Auxiliary frequency Y display	R	
Inverter fault address	5000H	Fault information code coincides with number of fault type in function code menu. But the data here returned to the host is in hexadecimal system and not fault character.	R

Description: Data read from 5000H compares with the actual fault as shown in the table below.

Inverter fault address	Description Inverter fault information description	
5000H	0000:No fault	0015:EEPROM read write error
	0001:Short-circuit protection	0016:Inverter hardware fault
	0002:Acceleration over current	0017:Motor short circuit to ground
	0003:Deceleration over current	0018:Reserved
	0004:Constant speed over current	0019:Reserved
	0005:Acceleration overvoltage	001A:Running time arrival

Inverter fault address	Description Inverter fault information description	
	0006:Deceleration overvoltage	001B:Reserved
	0007:Constant speed overvoltage	001C:Reserved
	0008:Reserved	001D:Power-on time arrival
	0009:Bus undervoltage fault	001E:Load failure
	000A:Inverter overload	001F:The PID feedback disconnected
	000B:Motor overload	0028:Wave-by-wave current limiting fault
	000C:Input phase loss	0029: Switching motor fault during operation
	000D:Output phase loss	002a: Excessive speed deviation
	000E:Module overheat	002b: Motor over speed
	000F:External fault	002d: Motor over temperature
	0010:Communication error	005a: Encoder wire number setting error
	0011:Contactor fault	005b: Encoder not connected
	0012:Current detection fault	005C: Initial position error
	0013:Motor self-learning error	005E: Speed feedback error
	0014:Reserved	

Communication error message response:

When a communication frame is detected as an error, the slave responds with a one-byte error code that defines the cause of the error. After the main device application receives an error code response, the typical process is to resend the message or make a command change for the corresponding error.

Communication error code definition:

Communication error home address	Wrong code definition
5001H	0000:No fault
	0001:Password error
	0002:Command code error
	0003:CRC checking error
	0004:Invalid address
	0005:Invalid parameters
	0006:Parameter change invalid
	0007:System locked
	0008:Being EEPROM operation

13 Wobble Frequency Counting Parameters

The wobble frequency function is suitable for textile, chemical fiber and other industries, as well as occasions requiring traversing and winding functions. The wobble frequency function means that the output frequency of the inverter wobble up and down with the set frequency as the center. The trajectory of the running frequency on the time axis is shown in Figure 5-29. The wobble amplitude is set by 13-00 and 13-01. When 13-00 is set to 0, that is, the wobble amplitude is 0, the wobble frequency has no effect.

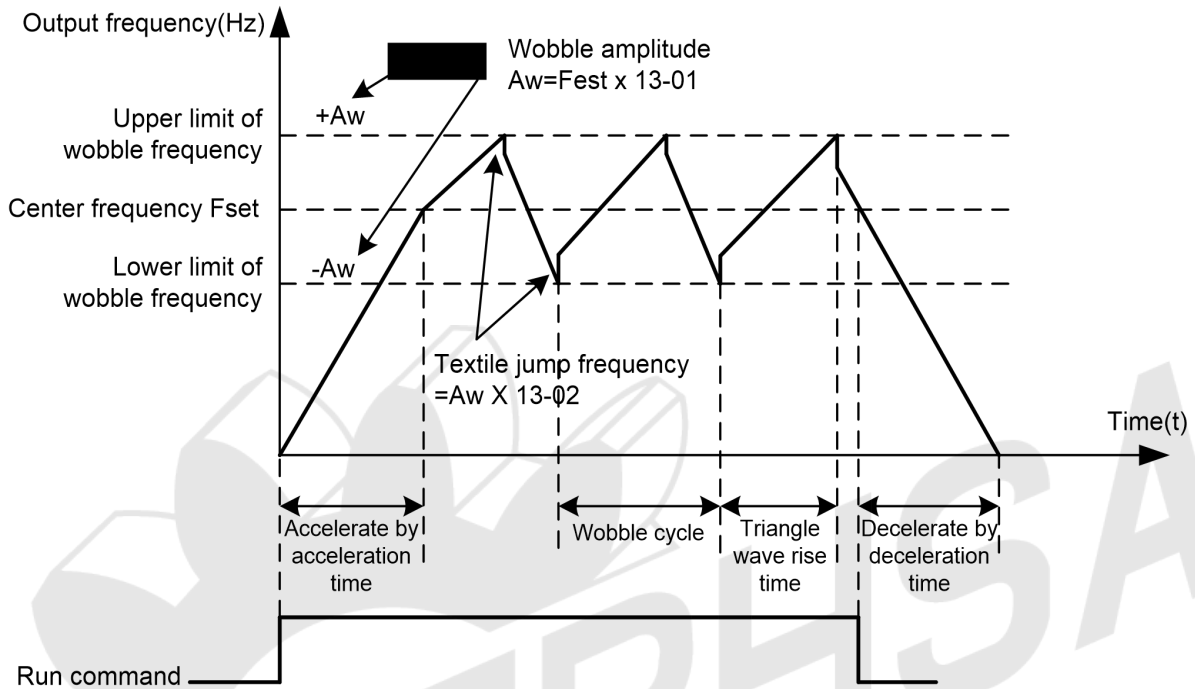

Figure 5-29 Schematic diagram of wobble frequency operation

13-00	Wobble setting mode		↗	Factory setting	0
	Setting range	0	Relative to center frequency		
		1	Relative to Max frequency		

Use this parameter to determine the reference amount of wobble.

0: Relative to the center frequency (00-17 frequency source). The wobble amplitude changes with the change of the center frequency (set frequency), and the wobble amplitude is not fixed.

1: Relative maximum frequency (00-03). The wobble is fixed.

13-01	Wobble amplitude		↗	Factory setting	0.0%
	Setting range	0.0% ~ 100.0%			
13-02	Jump frequency amplitude		↗	Factory setting	0.0%
	Setting range	0.0% ~ 50.0%			

Use this parameter to determine the value of wobble amplitude and kick frequency.

When setting the wobble amplitude relative to the center frequency (13-00=0), the wobble amplitude $AW = \text{frequency source (00-17)} \times \text{wobble amplitude (13-01)}$. When setting the wobble amplitude relative to the maximum frequency (13-00=1), the wobble amplitude $AW = \text{maximum frequency (00-03)} \times \text{wobble amplitude (13-01)}$.

Sudden jump frequency amplitude: Sudden jump frequency = wobble amplitude $AW \times$ sudden jump frequency amplitude (13-02). If the wobble amplitude is selected relative to the center frequency (13-00=0), the kick frequency is the changing value. If the wobble amplitude is selected relative to the maximum frequency (13-00=1), the kick frequency is a fixed value.

The operating frequency of the wobble frequency is constrained by the upper and lower frequency limits.

13-03	Wobble frequency cycle	↗	Factory setting	10.0s
	Setting range	0.1s~3000.0s		
13-04	Wobble triangle wave rise time	↗	Factory setting	50.0%
	Setting range	0.1%~100.0%		

Wobble cycle: the time value of a complete wobble cycle.

The triangular wave rise time (13-04) of the wobble frequency is the percentage of the triangular wave rise time relative to the wobble period (13-03).

Triangle wave rise time=(13-03)×(13-04), the unit is second.

Triangle wave fall time=(13-03)×(1-(13-04)), the unit is second.

13-05	Set length	↗	Factory setting	0m
	Setting range	0m~65535m		
13-06	Actual Length	↗	Factory setting	0m
	Setting range	0m~65535m		
13-07	Pulses per meter	↗	Factory setting	100.0
	Setting range	0.1~6553.5		

The above parameters are used for fixed length control.

The length information needs to be collected through the multifunctional digital input terminal. The number of pulses sampled by the terminal is divided by 13-07 pulses per meter, and the actual length 13-06 can be calculated. When the actual length is greater than the set length 13-05, the multi-function output terminal (function 10) outputs an ON signal.

During the fixed-length control, the length reset operation can be performed through the multi-function MI terminal (MI function selection is 28). For details, please refer to 04-00~04-04.

In application, the corresponding multi-function input terminal function needs to be set to "length count input" (function 27). When the pulse frequency is high, the MI5 port must be used.

13-08	Set count value	↗	Factory setting	1000
	Setting range	1~65535		
13-09	Designated count value	↗	Factory setting	1000
	Setting range	1~65535		

The count value needs to be collected through the multi-function digital input terminal. The application needs to set the corresponding multi-function input terminal function to "counter input" (function 25). When the pulse frequency is high, the MI5 port must be used.

When the count value reaches the set count value 13-08, the multi-function output terminal (function 8) outputs an ON signal, and then the counter stops counting.

When the count value reaches the designated count value 13-09, the multi-function output terminal (Function 9) outputs an ON signal. At this time, the counter continues to count until the "set count value" stops the counter.

The designated count value 13-09 should not be greater than the set count value 13-08.

Figure 5-30 is a schematic diagram of the set count value arrival and designated count value arrival functions.

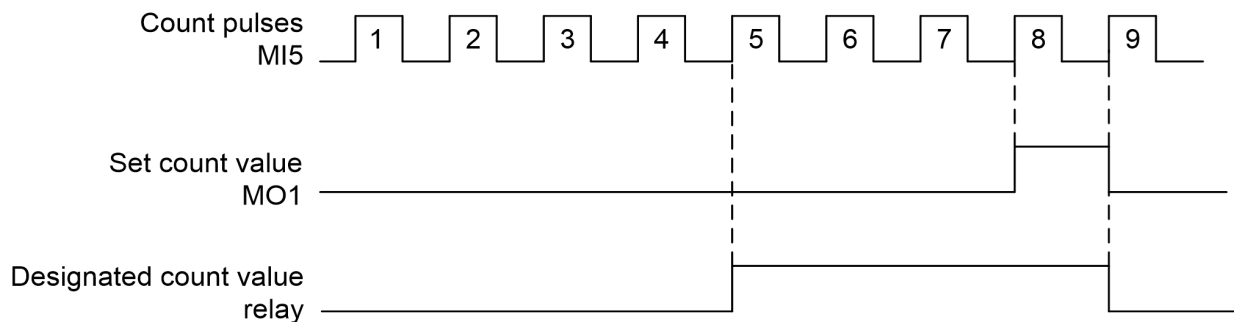

Figure 5-30 Schematic diagram of set count value and designated count value

16 Parameter management

16-01	Dedicated macro parameters		Factory setting	0
	Setting range	0~65535 (0 means general model)		
16-04	Parameter modification properties		↗	Factory setting 0
	Setting range	0	Parameters can be read and written	
		1	The parameter is read-only	

17 Torque Control Parameters

17-00	Speed/torque control method selection		Factory setting	0
	Setting range	0	Speed control	
		1	Torque control	

Select the control method of the inverter.

The S3100A's multi-function input M I terminal has two functions related to torque control: torque control prohibition (function 29) and speed control/torque control switching (function 46). These two terminals should be used in conjunction with 17-00 to achieve the switching between speed and torque control.

When the speed control/torque control switching terminal is invalid, the control mode is determined by 17-00. If the speed control/torque control switching is effective, the control mode is equivalent to the reverse of the value of 17-00.

When the torque control inhibit terminal is valid, the inverter is fixed to speed control mode.

17-01	Torque setting source selection in torque control mode		Factory setting	0
	Setting range	0	Digital setting(17-03)	
		1	AVI1	
		2	AVI2/ACI	
		3	Reserved	
		4	PULSE	

17-01	Torque setting source selection in torque control mode		Factory setting	0
	5	Communication setting		
	6	MIN(AVI1, AVI2/ACI)		
	7	MAX(AVI1, AVI2/ACI)		
	1-7 option full scale, corresponding to 17-03 digital setting			
17-03	Torque digital setting in torque control mode		↗	Factory setting 150.0%
	Setting range	-200.0%~200.0%		

Used to select the torque setting source.

The torque setting adopts a relative value, and 100.0% corresponds to the rated torque of the inverter. Setting range-200.0%~200.0%, indicating that the maximum torque of the inverter is 2 times the rated torque of the inverter.

When the torque setting source is selected from 1 to 7, 100% of communication, analog input, and pulse input correspond to 17-03.

17-05	Torque control forward maximum frequency		↗	Factory setting 50.00Hz
	Setting range	0.00Hz~Max frequency (00-03)		
17-06	Torque control reverse maximum frequency		↗	Factory setting 50.00Hz
	Setting range	0.00Hz~Max frequency (00-03)		

It is used to set the maximum running frequency of inverter forward or reverse in torque control mode.

When the inverter torque control, if the load torque is less than the motor output torque, it will continue to rise, in order to prevent accidents such as speeding of the mechanical system, the maximum speed of the motor during torque control must be limited.

17-07	Torque control acceleration time		↗	Factory setting 0.00s
	Setting range	0.00s~65000s		
17-08	Torque control Deceleration time		↗	Factory setting 0.00s
	Setting range	0.00s~65000s		

In the torque control mode, the difference between the motor output torque and the load torque determines the speed change rate of the motor and the load, so the motor speed may change rapidly, causing problems such as excessive noise or mechanical stress. By setting the torque control acceleration and deceleration time, the motor speed can be changed gently.

However, when quick torque response is required, the torque control acceleration/deceleration time needs to be set to 0.00s. For example, two motors are connected by a hard connection to drive the same load. In order to ensure that the load is evenly distributed, one inverter is set as the master to adopt the speed control mode, the other inverter is the slave and uses torque control, the actual output torque of the master As the torque command of the slave, the torque of the slave needs to quickly follow the master at this time, then the acceleration and deceleration time of the torque control of the slave is 0.00s.

22 Control Optimization Parameters

22-00	DPWM switching upper limit frequency		↗	Factory setting	8.00Hz
	Setting range	5.00Hz~Maximum operating frequency			

Only valid for V/f control. When the V/f is running, the wave transmission mode is lower than this value for the 7-segment continuous modulation mode, and the opposite is the 5-segment intermittent modulation mode.

In the 7-segment continuous modulation, the switching loss of the inverter is large, but the current ripple is small; in the 5-step intermittent debugging mode, the switching loss is small and the current ripple is large; but it may cause the motor at high frequency. The instability of operation generally does not require modification.

For the V/f operation instability, please refer to parameter 03-11, for inverter loss and temperature rise, please refer to parameter 00-10;

22-01	Modulation		↗	Factory setting	0
	Setting range	0	Asynchronous modulation		
		1	Synchronous modulation		

22-02	Dead zone compensation mode selection		↗	Factory setting	1
	Setting range	0	No compensation		
		1	Compensation mode 1		

This parameter generally does not need to be modified. Only when there are special requirements on the quality of the output voltage waveform, or when the motor exhibits abnormalities such as oscillation, it is necessary to try to switch between different compensation modes. It is recommended to use compensation mode 2 for high power.

22-03	Random PWM depth		↗	Factory setting	0
	Setting range	0	Random PWM is invalid		
		1~10	Random depth of PWM carrier frequency		

Setting random PWM can make the monotonous harsh motor sound softer, and can help reduce external electromagnetic interference. When the random PWM depth is set to 0, random PWM is invalid. Adjust the random PWM to different depths to get different effects.

22-04	Fast current limit enable		↗	Factory setting	1
	Setting range	0	No enabling		
		1	Enabling		

Enabling the fast current limit function can minimize the overcurrent fault of the inverter and ensure the continuous operation of the inverter. If the inverter continues to be in the fast current limiting state for a long time, the inverter may be damaged due to overheating, etc. This situation is not allowed.

Therefore, the inverter is used in the occasion of large current impact for a long time, please select 1, the rapid current limit will alarm the fault CBC after a period of time, indicating that the inverter is overloaded and needs to be stopped.

22-05	Current detection compensation		Factory setting	105
	Setting range	100~110		

It is used to set the current detection compensation of the inverter. If the setting is too large, the control performance may be reduced. Generally no modification is required.

22-06	Undervoltage level	↗	Factory setting	220V:200V 380V:350V
	Setting range	DC0V-DC420V		

It is used to set the voltage value of the undervoltage fault UV of the inverter. 100.0% of the inverters with different voltage levels correspond to different voltage points, respectively:

Single-phase 220V or three-phase 220V: DC200V

Three-phase 380V: DC350V

When the low voltage level is set to 0.1V, it means that no matter what the bus voltage is, the inverter will not report a low voltage UV alarm and will always run at its maximum capacity.

99 Monitoring Parameters

The 99 parameter group is used to monitor the running status information of the inverter. The user can view it through the operation panel, or read the value of the parameter group through communication in order to view the data on the spot or monitor the data of the host computer. Among them, 99-00 to 99-31 are the same as the monitoring parameters defined in 08-03/08-04.

See the table below for details.

Parameter	Name	Unit
99-00	Running frequency(Hz)	0.01Hz
99-01	Setting frequency(Hz)	0.01Hz
99-02	Bus voltage(V)	0.1V
99-03	Output voltage(V)	1V
99-04	Output current(A)	0.01A
99-05	Output power(kW)	0.1kW
99-06	Output torque(%)	0.10%
99-07	MI Input status	1
99-08	MO Output status	1
99-09	AVI1 Voltage(V)	0.01V
99-10	AVI2/ACI Voltage(V)	0.01V
99-11	Reserved	
99-12	Calculation value	1
99-13	Length	1
99-14	Load speed	1
99-15	PID setting	1

Parameter	Name	Unit
99-16	PID feedback	1
99-17	PLC stage	1
99-18	PULSE Input pulse frequency(Hz)	0.01kHz
99-19	Feedback speed(Unit 0.1Hz)	0.1Hz
99-20	Remaining running time	0.1Min
99-21	AVI1 voltage before calibration	0.001V
99-22	AVI2/ACI voltage before calibration	0.001V
99-23	Counter 2 low position	
99-24	Counter 2 high position	1(99-23 is 1 too)
99-25	Current power-on time	1Min
99-26	Current running time	0.1Min
99-27	PULSE Input pulse frequency	1Hz
99-28	Communication setting value	0.01%
99-29	Reserved	
99-30	Main frequency X display	0.01Hz
99-31	Auxiliary frequency Y display	0.01Hz
99-32	View any memory address value	1
99-33	Reserved	
99-34	Reserved	
99-35	Target torque (%)	0.10%
99-36	Reserved	
99-37	Reserved	
99-38	Reserved	
99-39	V/f separation target voltage	1V
99-40	V/f separation output voltage	1V
99-41	Visual display of MI input status	1
99-42	Visual display of MO input status	1
99-43	MI function status visual display 1	1
99-44	MI function status visual display 2	1

6 TROUBLE SHOOTING

AC motor drive is provided with functions of warning and protection such as over voltage, low voltage and over current. Once fault occurs, protection function shall act, AC motor drive output stop, fault contactor act and also free running of motor shall stop. For causes and corrective measures of fault, display of fault shall be taken for reference. The alarm records will be stored into the computer memory of AC motor driver. Attention shall be paid that RESET key, would be available only after the fault has been eliminated.

6.1 Failures & Failure Elimination

Display	Description	Possible reason	corrective-measures
sc	Short circuit fault	<ol style="list-style-type: none"> 1. Accelerate too fast. 2. Internal damage of IGBT. 3. Malfunction caused by interference. 4. Whether the grounding is good. 	<ol style="list-style-type: none"> 1. Increase acceleration time. 2. Seek support. 3. Check whether the peripheral equipment has a strong interference source.
oc1	Overcurrent during acceleration	<ol style="list-style-type: none"> 1. Accelerate too fast. 2. The input power voltage is low. 3. The power of the inverter is too small. 4. No parameter learning is performed during vector control. 5. Manual torque boost or V/f curve is not suitable. 6. The motor is rotating when starting. 7. There is a short circuit in the inverter output circuit. 	<ol style="list-style-type: none"> 1. Increase the acceleration time. 2. Check the input power. 3. Select a inverter with a higher power. 4. Perform parameter self-learning. 5. Adjust manual lifting torque or V/f curve. 6. Choose speed tracking or start after the motor stops. 7. Eliminate peripheral faults.
oc2	Overcurrent during deceleration	<ol style="list-style-type: none"> 1. Decelerate too fast. 2. Large load inertia torque. 3. The power of the inverter is too small. 4. No parameter learning is performed during vector control. 5. There is a short circuit in the inverter output circuit. 	<ol style="list-style-type: none"> 1. Increase the deceleration time. 2. Add appropriate energy consumption brake components. 3. Select a frequency converter with a higher power. 4. Perform parameter self-learning. 5. Eliminate peripheral faults.
oc3	Overcurrent at constant speed	<ol style="list-style-type: none"> 1. Abrupt or abnormal load. 2. The input power voltage is low. 3. The power of the inverter is too small. 4. No parameter learning is performed during vector control. 5. There is a short circuit in the inverter output circuit. 	<ol style="list-style-type: none"> 1. Check the load or reduce the sudden change of load. 2. Check the input power. 3. Select a frequency converter with a higher power. 4. Perform parameter self-learning. 5. Eliminate peripheral faults.
ov1	Overvoltage during acceleration	<ol style="list-style-type: none"> 1. The input voltage is abnormal. 2. After a momentary power failure, restart the rotating motor. 	<ol style="list-style-type: none"> 1. Check the input power. 2. Avoid restarting after stopping.
ov2	Overvoltage during deceleration	<ol style="list-style-type: none"> 1. Decelerate too fast. 2. Large load inertia. 3. The input voltage is abnormal. 	<ol style="list-style-type: none"> 1. Increase the deceleration time. 2. Increase energy consumption brake components. 3. Check the input power.

Display	Description	Possible reason	corrective-measures
ov3	Overvoltage at constant speed	<ol style="list-style-type: none"> 1. Abnormal changes in input voltage. 2. The load inertia is large. 	<ol style="list-style-type: none"> 1. Install input reactor. 2. Plus suitable energy consumption brake components.
uv	BUS undervoltage	<ol style="list-style-type: none"> 1. The input power supply voltage is low. 2. Instant power outage. 3. The circuit board is abnormal. 	<ol style="list-style-type: none"> 1. Check the input power 2. Reset fault 3. Seek service
ol2	Inverter overload	<ol style="list-style-type: none"> 1. Accelerate too fast. 2. Restart the rotating motor. 3. The input power voltage is too low. 4. The load is too large. 	<ol style="list-style-type: none"> 1. Increase the acceleration time. 2. Avoid restarting after shutdown. 3. Check the input power voltage 4. Select the inverter with higher power.
ol1	Motor overload	<ol style="list-style-type: none"> 1. The input power voltage is too low. 2. The motor rated current is set incorrectly. 3. The motor is blocked or the load mutation is too large. 4. Motor overloaded. 	<ol style="list-style-type: none"> 1. Check the input power voltage. 2. Reset the rated current of the motor. 3. Check the load and adjust the torque boost. 4. Choose the right motor.
ol3	Motor overload 2	<ol style="list-style-type: none"> 1. The motor is blocked or the load is too large. 2. Improper setting of protection parameters. 	<ol style="list-style-type: none"> 1. Check the load. 2. Set appropriate protection parameters.
sp1	Input phase loss	R/L1,S/L2,T/L3 Input phase loss	<ol style="list-style-type: none"> 1. Check the input power. 2. Check the installation wiring.
spo	Output phase loss	U/T1,V/T2,W/T3 phase loss on output side (or the load three-phase is severely asymmetric)	<ol style="list-style-type: none"> 1. Check the output wiring. 2. Check the motor and cable
oh2	Module overheat	<ol style="list-style-type: none"> 1. Inverter overcurrent instantly. 2. The output three phases have interphase or ground short circuit. 3. The air duct is blocked or the fan is damaged. 4. The ambient temperature is too high. 5. Loose connection of control board or plug-in. 6. The auxiliary power supply is damaged, and the driving voltage is undervoltage. 7. Power module bridge arm is straight through. 8. The control board is abnormal. 	<ol style="list-style-type: none"> 1. See overcurrent countermeasures. 2. Rewiring. 3. Ventilate channels or replace fans. 4. Reduce the ambient temperature. 5. Check and reconnect. 6. Seek service. 7. Seek service. 8. Seek service.
ef	External fault	Ml external fault input terminal action	Check external device input
ce	Communication error	<ol style="list-style-type: none"> 1. The baud rate is not set properly. 2. Communication error using serial communication. 3. Communication is interrupted for a long time. 	<ol style="list-style-type: none"> 1. Set the appropriate baud rate. 2. Press STOP/RESET button to reset and seek service. 3. Check the wiring of the communication interface.

Display	Description	Possible reason	corrective-measures
IE	Current detection circuit fault	<ol style="list-style-type: none"> Poor contact of the control board connector. The auxiliary power supply is damaged. The Hall device is damaged. The amplifier circuit is abnormal. 	<ol style="list-style-type: none"> Check the connector and reinsert the cable. Search for factory maintenance. Search for factory maintenance. Search for factory maintenance.
SC	Motor to ground short circuit fault	Short circuit of motor to ground	Check the motor or change the cable or motor
EE	Motor auto-tuning error	<ol style="list-style-type: none"> The capacity of the motor does not match the capacity of the inverter. Improper setting of rated motor parameters. The deviation of the self-learned parameters and the standard parameters is too large. Auto-tuning timeout. 	<ol style="list-style-type: none"> Replace the inverter model. Set rated parameters according to the motor nameplate. Make the motor empty and re-identify. Check the motor wiring and parameter settings.
EEP	EEPROM reading-writing error	<ol style="list-style-type: none"> An error occurs in the reading and writing of control parameters. The EEPROM is damaged. 	<ol style="list-style-type: none"> Press STOP/RESE key and search for factory maintenance. Search for factory maintenance
Eond	Accumulated running time reaches fault	Cumulative running time to set value	Use the parameter initialization function to clear the record information.
E Ind	Accumulated power-on time reaches error	The cumulative power-on time reaches the set value.	Use the parameter initialization function to clear the record information.
oLL	Load failure	The running current of the inverter is less than 11-64.	Check whether the load or 11-64, 11-65 parameters are in accordance with the actual working conditions.
EP Id	PID feedback disconnection fault	<ol style="list-style-type: none"> PID feedback disconnected. The PID feedback source disappears. 	<ol style="list-style-type: none"> Check the PID feedback signal line. Check the PID feedback source.
CB	Wave-by-wave current limiting fault	<ol style="list-style-type: none"> Whether the load is too large or the motor stalls. Inverter power is too small. 	<ol style="list-style-type: none"> Reduce the load and check the motor and mechanical conditions. Select the inverter with higher power.
End			Contact the service provider
EB	Charging resistor fault	Whether the input power is abnormal	Check the input power
E42	Power-on initialization abnormal	<ol style="list-style-type: none"> Whether the input power supply is abnormal. The power supply or device is damaged. 	<ol style="list-style-type: none"> Check the power supply. Seek service.

6.2 General Troubleshooting Method

Abnormal phenomenon	Check points	Processing content
The motor does not run	Has the power supply voltage been sent to R/L1, S/L2, and T/L3?	Whether the power supply is input; Turn off the power first and then send it again; Confirm the power voltage level; Whether the terminal screw is tight.
	Is there voltage output at the output terminals U/T1, V/T2, W/T3?	Turn off the power first and then send it again
	Check if the load is too heavy, causing the motor to block?	Reduce the load so that the motor can run
	Check if there is any abnormality in the inverter?	Refer to the troubleshooting instructions to deal with wiring inspection and correction
	Are forward or reverse instructions issued?	
	Check if there is an input for the analog frequency setting value?	Whether the analog frequency input signal wiring is correct; Whether the frequency input setting voltage is correct.
	Are the operating mode settings correct?	Operated by digital operation
Motor running Opposite direction	Are the output terminals U/T1, V/T2, and W/T3 wired correctly?	Must work with the U/T1,V/T2,W/T3 phase of the motor.
	Is the forward or reverse signal wiring correct?	Check and correct the wiring
Motor running Can't change speed	Is the analog frequency input wiring correct?	Check and correct the wiring
	Is the operation mode set correctly?	Operation panel operation mode setting check
	Is the load too heavy?	Lighten the load
Motor running speed is too high or too low	Is the motor specification (pole voltage) correct?	Check motor specifications
	Is the gear ratio correct?	Confirm gear ratio
	Is the maximum output frequency setting correct?	Confirm the maximum output frequency value
	Is there an extreme drop in the voltage at the motor end?	The V/f characteristic curve is set correctly
When the motor is running Abnormal speed changes	Will the load be too heavy?	Lighten the load
	Does the load change greatly?	Load fluctuation should be reduced; The capacity of the inverter and motor is increased.
	Is there any phase loss in the input power supply?	When using single-phase specifications, add AC reactor on the input power side; Check wiring when using three-phase specifications.

7 MAINTENANCE AND AMBIENT ELEMENTS

For safety and normal operation, the inverter shall be provided with daily as well as periodical maintenance.

Diagram below shows items that must be checked.

Check shall only performed 10 minutes after charging LEDs of the inverter go off, to prevent injury to operators caused by residual power of inverter condenser.

Inspection item	Inspection content	Inspection period		Inspection method	Assessment base	Corrective measures to fault
		Daily	Annual			
Machine ambient environment	Verify ambient temperature and humidity	○		Measure with temperature or humidity meter in accordance with notes for installation	Temperature:-10 to 40°C; humidity:below 95%RH	Improve environments
	Check stacking with inflammable materials	○		View inspection	No foreign materials	
Inverter installing and grounding	Check abnormal vibration to machine	○		View and auditory inspection	No foreign materials	Tighten securing screws
	Check grounding resistance complies with specification		○	Measure resistance with three-functional meter	200V Class: below 100Ω; 400V Class: below 100Ω	Modify grounding
Input power supply voltage	Check main circuit voltage	○		Measure resistance with three-functional meter	Voltage value complies with specifications	Modify input power supply
External terminal securing screws of the inverter	Check security of screwed parts		○	View inspection and check screws are secured tightly with screwdriver	All OK	Tighten or sent for factory maintenance and overhaul
	Check terminal board is not damaged		○			
	Check no clear rust exists		○			
Inverter inner wiring	Check no distortion appears		○		All OK	
	Check outer shielding is not broken		○	View inspection	All OK	Replace or sent for factory maintenance and overhaul
Radiator	Check no dust or chipping stacked	○		View inspection	All OK	Remove stacking such as dust

Inspection item	Inspection content	Inspection period		Inspection method	Assessment base	Corrective measures to fault
		Daily	Annual			
Printing circuit board	Check no inductive metal or oil stacked		○	View inspection	All OK	Remove or replace electric board
	Check elements are exclusive of color changing or burning due to overheat		○			
Cooling fan	Check abnormal vibration or noise		○	View inspection and auditory inspection	All OK	Replace cooling fan
	Check no dust or chipping stacked	○		View inspection		Remove
Power elements	Check no dust or chipping stacked		○	View inspection	All OK	Remove
	Check resistance between terminals		○	Check using three-functional meter	No short circuit or circuit break for three phase output	Replace power elements or inverter
Condenser	Check for odor or leakage	○		View inspection	All OK	Replace condenser or inverter
	Check for expansion or distortion	○				

Always inspection and maintenance is not necessary for S3100A.

For long time safety operation, periodical inspection shall be prepared to the inverter in accordance with descriptions below. Inspection shall only performed after power supply is off and charging LED off (since residual voltage may exist in the large capacity condensers.)

- 1.Remove dirty stacking inside the machine
- 2.Check screws securing terminals or elements are securely tightened; if not, tighten the screws.

7.1 Braking Resistor Selection Guide

The choice of braking resistor needs to be determined according to the power generated by the motor in the actual application system and has the relationship with the inertia of the system, the deceleration time, the energy that the bit can load, etc., and needs the customer to choose according to the actual situation. The larger the system inertia, the shorter the deceleration time required, the more frequent braking, the greater the braking resistance power to choose, the smaller the resistance, but not lower than the recommended minimum resistance.

(1) When braking, the regenerative energy of the motor is almost entirely consumed on the brake resistor.

The formula is: $U \times U / R = P_b$

U - braking voltage with stable system brake (440V-class default is DC750V, 220V-class default is DC360V)

P_b - braking power

(2) Brake resistor power selection

The power of the brake resistor is theoretically the same to the braking power, but considering the derating is 70%.

The formula is: $0.7 \times P_r = P_b \times ED$

P_r - resistance power

ED - brake rate (brake process accounts for the proportion of the entire work process)

Common occasions	Centrifuge	General brake load
Brake rate(ED)	50~60%	5%~10%

(3) Brake resistor selection calculation reference

- ① 380V5.5kW motor applications, for example, check the table below to get:10% braking resistor resistance specifications:500W100Ω, as applied to the lifting industry needs up to 30% of the braking rate, the formula between the resistance power and braking rate is in direct proportion,Therefore, the choice of resistance specifications:500W x (30% / 10%) = 1500W100Ω.
- ② If the braking torque is not enough, the test will need to use 80Ω to ensure not jump OU (inverter over-voltage), the formula that the resistance is inversely proportional to the braking power, Therefore, the new resistance specification at 10% ED is:500W x (100Ω / 80Ω) = 625W80Ω.
- ③ If the lifting load is heavy, also needs 80Ω resistor and 30% braking rate,Then the new resistance specifications:625W x (30% / 10%) = 1875W80Ω.

Braking Resistor List

220V

Voltage	Applicable motor		Full load output torque (Nm)	Braking unit	Braking resistor	Braking torque 10%ED%	Min resistance
	HP	kW		Quantity	Quantity		
220V Series	0.5	0.4	2.22	Built-in	80W 400Ω	125	150Ω
					1		
	1	0.75	4.15		80W 200Ω	125	80Ω
					1		
	2	1.5	8.31		300W 100Ω	125	55Ω
					1		
	3	2.2	12.19		300W 70Ω	125	35Ω
					1		
	5	4.0	20.49		400W 40Ω	125	30Ω
					1		
	7.5	5.5	30.46		1000W 20Ω	125	12Ω
					1		
	10	7.5	41.54		1000W 20Ω	125	12Ω
					1		
	15	11	60.93		1500W 13Ω	100	13.6Ω
					1		
	20	15	83.09		2000W 8.6Ω	100	8.3Ω
					1		
	25	18.5	102.47		2000W 8.6Ω	100	8.3Ω
					1		
30	22	121.86	3000W 6.6Ω	100	5.8Ω		
			1				
40	30	166.17	DBU-2030C	4000W 5.1Ω	100	5.1Ω	
			1	1			
50	37	204.94	DBU-2030C	4800W 3.9Ω	100	3.2Ω	
			2(parallel connection)	1			
60	45	249.26	DBU-2030C	6000W 3.3Ω	100	3.2Ω	
			2(parallel connection)	1			
75	55	304.65	DBU-2030C	7200W 2.6Ω	100	2.6Ω	
			2(parallel connection)	1			

440V

Voltage	Applicable motor		Full load output torque (Nm)	Braking unit	Braking resistor	Braking torque 10%ED%	Min resistance
	HP	kW		Quantity	Quantity		
440V Series	1	0.75	4.15	Built-in	80W 750Ω	125	260Ω
					1		
	2	1.5	8.31		300W 400Ω	125	190Ω
					1		
	3	2.2	12.19		300W 250Ω	125	145Ω
					1		
	5	4.0	22.16		400W 150Ω	125	95Ω
					1		
	7.5	5.5	30.46		500W 100Ω	125	60Ω
					1		
	10	7.5	41.54		1000W 75Ω	125	45Ω
					1		
	15	11	60.93		1000W 50Ω	125	50Ω
					1		
	20	15	83.09		1500W 40Ω	125	40Ω
					1		
	25	18.5	102.47		4800W 32Ω	125	32Ω
					1		
	30	22	121.86		4800W 27.2Ω	125	27.2Ω
					1		
40	30	166.17	6000W 20Ω	100	20Ω		
			1				
50	37	204.94	9600W 13.6Ω	100	13.6Ω		
			1				
60	45	249.26	9600W 13.6Ω	100	13.6Ω		
			1				
75	55	304.65	DBU-4030D	6000W 20Ω	100	20Ω	
			2(parallel connection)	2			
100	75	415.43	DBU-4045C	9600W 13.6Ω	100	13.6Ω	
			2(parallel connection)	2			
120	90	498.51	DBU-4045C	9600W 13.6Ω	100	13.6Ω	
			2(parallel connection)	2			

Voltage	Applicable motor		Full load output torque (Nm)	Braking unit	Braking resistor	Braking torque 10%ED%	Min resistance
	HP	kW		Quantity	Quantity		
440V Series	150	110	609.29	DBU-4110B	30000W 6.8Ω	100	6.8Ω
				1	1		
	180	132	731.15	DBU-4220B	30000W 4Ω	100	4Ω
				1	1		
	215	160	886.24	DBU-4220B	40000W 4Ω	100	3.4Ω
				1	1		
	250	185	1024.72	DBU-4220B	40000W 4Ω	100	3.4Ω
				1	1		
	270	200	1107.80	DBU-4220B	40000W 4Ω	100	3.4Ω
				1	1		
	300	220	1218.58	DBU-4220B	60000W 4Ω	100	3.2Ω
				1	1		
	340	250	1384.75	DBU-4300	80000W 2.5Ω	100	2.5Ω
				1	1		
	380	280	1550.92	DBU-4300	80000W 2.5Ω	100	2.5Ω
				1	1		
	430	315	1744.79	DBU-4300	80000W 2.5Ω	100	2.5Ω
				1	1		
	470	355	1966.35	DBU-4300	60000W 3Ω	100	3Ω
				2(parallel connection)	2		
540	400	2215.60	DBU-4300	60000W 3Ω	100	3Ω	
			2(parallel connection)	2			
600	450	2492.55	DBU-4300	80000W 2.5Ω	100	2.5Ω	
			2(parallel connection)	2			
700	500	2770	DBU-4300	90000W 2.5Ω	100	2.5Ω	
			2(parallel connection)	2			

Notes:

- 1.Watts of voltage value and frequency applied(ED %) shall be in accordance with specifications of this company.
- 2.This company shall not be responsible for damaging of inverter or other devices, which shall be caused by braking resistor or braking module that were not produced by this company.
- 3.When installing braking resistor, great care shall be attached on safety or inflammability of the ambient environments.
- 4.In case of Min resistance shall be used, contact your SAVCH ELECTRIC for suggestion of watts calculating.

7.2 Breaker,Cable and Contactor Specifications List

Model	Breaker(A)	Input cable/Output cable (Copper wire cable)mm ²	Contactor rated current A
S3100A-2T0.4G	16	2.5	10
S3100A-2T0.75G	16	2.5	10
S3100A-2T1.5G	20	4	16
S3100A-2T2.2G	32	4	25
S3100A-2T4.0G	32	6	25
S3100A-2T5.5G	63	6	32
S3100A-2T7.5G	100	10	63
S3100A-2T11G	100	16	80
S3100A-2T15G	125	25	95
S3100A-2T18.5G	160	25	120
S3100A-2T22G	160	35	135
S3100A-2T30G	225	50	170
S3100A-2T37G	250	70	230
S3100A-2T45G	315	95	280
S3100A-2T55G	315	95	280
S3100A-4T0.75G/1.5P	16	2.5	10
S3100A-4T1.5G/2.2P	16	2.5	10
S3100A-4T2.2G/4.0P	16	2.5	10
S3100A-4T4.0G/5.5P	25	4	16
S3100A-4T5.5G/7.5P	25	4	16
S3100A-4T7.5G	40	6	25
S3100A-4T7.5G/11P	40	6	25
S3100A-4T11G/15P	63	6	32
S3100A-4T15G/18.5P	63	6	50
S3100A-4T18.5G/22P	100	10	63
S3100A-4T22G/30P	100	16	80
S3100A-4T30G/37P	125	25	95
S3100A-4T37G/45P	160	25	120
S3100A-4T45G/55P	160	35	135
S3100A-4T55G/75P	225	50	170
S3100A-4T75G/90P	250	70	230
S3100A-4T90G/110P	315	95	280
S3100A-4T110G	315	95	280

Model	Breaker(A)	Input cable/Output cable (Copper wire cable)mm ²	Contactor rated current A
S3100A-4T110G/132P	350	120	315
S3100A-4T132G/160P	400	120	380
S3100A-4T160G	500	120	450
S3100A-4T185G/200P	500	185	500
S3100A-4T200G/220P	630	185	580
S3100A-4T220G	630	240	630
S3100A-4T220G/250P	630	240	630
S3100A-4T250G/280P	700	2 x 120	700
S3100A-4T280G/315P	800	2 x 120	780
S3100A-4T315G	1000	2 x 150	800
S3100A-4T315G/355P	1000	2 x 150	800
S3100A-4T355G/400P	1250	2 x 185	800
S3100A-4T400G/450P	1250	2 x 240	1000
S3100A-4T450G/500P	1250	2 x 240	1000
S3100A-4T500G	1250	2 x 240	1000

7.3 Input/Output AC Reactor and DC Reactor Specifications

Model	Input AC reactor (recommended)	Output AC reactor (recommended)	DC reactor(recommended)
S3100A-2T0.4G	ACL-0005-EISC-E2M8C	OCL-0005-EISC-E1M4	×
S3100A-2T0.75G	ACL-0005-EISC-E2M8C	OCL-0005-EISC-E1M4	×
S3100A-2T1.5G	ACL-0007-EISC-E2M0C	OCL-0005-EISC-E1M4	×
S3100A-2T2.2G	ACL-0010-EISC-E1M4C	OCL-0010-EISC-EM70	×
S3100A-2T4.0G	ACL-0020-EISC-EM70C	OCL-0020-EISC-EM35	×
S3100A-2T5.5G	ACL-0030-EISCL-EM47C	OCL-0030-EISCL-EM23C	×
S3100A-2T7.5G	ACL-0040-EISCL-EM35C	OCL-0040-EISCL-EM18	×
S3100A-2T11G	ACL-0060-EISCL-EM24C	OCL-0060-EISCL-EM12C	DCL-0050-EIDH-E1M1
S3100A-2T15G	ACL-0090-EISCL-EM16	OCL-0080-EISC-E87U	DCL-0065-EIDH-EM80
S3100A-2T18.5G	ACL-0090-EISCL-EM16	OCL-0090-EISC-E78U	DCL-0078-EIDH-EM70
S3100A-2T22G	ACL-0120-EISCL-EM12C	OCL-0120-EISC-E58UC	DCL-0095-EIDH-EM54
S3100A-2T30G	ACL-0150-EISH-E95UC	OCL-0150-EISH-E47UC	DCL-0115-EIDH-EM45
S3100A-2T37G	ACL-0200-EISH-E70UC	OCL-0200-EISH-E35UC	DCL-0160-UIDH-EM36
S3100A-2T45G	ACL-0250-EISH-E56UC	OCL-0250-EISH-E28UC	DCL-0180-UIDH-EM33
S3100A-2T55G	ACL-0250-EISH-E56UC	OCL-0250-EISH-E28UC	DCL-0250-UIDH-EM26

Model	Input AC reactor (recommended)	Output AC reactor (recommended)	DC reactor(recommended)
S3100A-4T0.75G/1.5P	ACL-0005-EISC-E2M8C	OCL-0005-EISC-E1M4	×
S3100A-4T1.5G/2.2P	ACL-0005-EISC-E2M8C	OCL-0005-EISC-E1M4	×
S3100A-4T2.2G/4.0P	ACL-0007-EISC-E2M0C	OCL-0007-EISC-E1M0	×
S3100A-4T4.0G/5.5P	ACL-0015-EISC-EM93C	OCL-0015-EISC-EM47	×
S3100A-4T5.5G/7.5P	ACL-0015-EISC- EM93C	OCL-0015-EISC-EM47	×
S3100A-4T7.5G	ACL-0020-EISC-EM70C	OCL-0020-EISC-EM35	×
S3100A-4T7.5G/11P	ACL-0020-EISC-EM70C	OCL-0020-EISC-EM35	×
S3100A-4T11G/15P	ACL-0030-EISCL-EM47C	OCL-0030-EISC-EM23	×
S3100A-4T15G/18.5P	ACL-0040-EISCL-EM35C	OCL-0040-EISC-EM18	×
S3100A-4T18.5G/22P	ACL-0050-EISCL-EM28C	OCL-0050-EISC-EM14	×
S3100A-4T22G/30P	ACL-0060-EISCL-EM24C	OCL-0060-EISC-EM12	×
S3100A-4T30G/37P	ACL-0090-EISCL-EM16	OCL-0080-EISC-E87U	DCL-0065-EIDH-EM80
S3100A-4T37G/45P	ACL-0090-EISCL-EM16	OCL-0090-EISC-E78U	DCL-0078-EIDH-EM70
S3100A-4T45G/55P	ACL-0120-EISCL-EM12C	OCL-0120-EISC-E58UC	DCL-0095-EIDH-EM54
S3100A-4T55G/75P	ACL-0150-EISH-E95UC	OCL-0150-EISH-E47UC	DCL-0115-EIDH-EM45
S3100A-4T75G/90P	ACL-0200-EISH-E70UC	OCL-0200-EISH-E35UC	DCL-0160-UIDH-EM36
S3100A-4T90G/110P	ACL-0250-EISH-E56UC	OCL-0250-EISH-E28UC	DCL-0180-UIDH-EM33
S3100A-4T110G	ACL-0250-EISH-E56UC	OCL-0250-EISH-E28UC	DCL-0250-UIDH-EM26
S3100A-4T110G/132P	ACL-0250-EISH-E56UC	OCL-0250-EISH-E28UC	DCL-0250-UIDH-EM26
S3100A-4T132G/160P	ACL-0290-EISH-E48UC	OCL-0290-EISH-E24UC	DCL-0250-UIDH-EM26
S3100A-4T160G	ACL-0330-EISH-E42UC	OCL-0330-EISH-E21UC	DCL-0340-UIDH-EM17
S3100A-4T185G/200P	ACL-0390-EISH-E36UC	OCL-0390-EISH-E18U	DCL-0450-UIWH-161
S3100A-4T200G/220P	ACL-0490-EISH-E28UC	OCL-0490-EISH-E14UC	DCL-0460-UIDH-EM09
S3100A-4T220G	ACL-0490-EISH-E28UC	OCL-0490-EISH-E14UC	DCL-0460-UIDH-EM09
S3100A-4T220G/250P	ACL-0490-EISH-E28UC	OCL-0490-EISH-E14UC	DCL-0460-UIDH-EM09
S3100A-4T250G/280P	ACL-0530-EISH-E26UC	OCL-0530-EISH-E13U	DCL-0650-UIDH-E72U
S3100A-4T280G/315P	ACL-0600-EISH-E23UC	OCL-0600-EISH-E12UC	DCL-0650-UIDH-E72U
S3100A-4T315G	ACL-0660-EISH-E25UC	OCL-0660-EISH-E11U	DCL-0650-UIDH-E72U
S3100A-4T315G/355P	ACL-0660-EISH-E25UC	OCL-0660-EISH-E11U	DCL-0650-UIDH-E72U
S3100A-4T355G/400P	ACL-0800-EISH-E17UC	OCL-0800-EISH-E8U7C	DSL-0800-UIDA-E50U
S3100A-4T400G/450P	ACL-0800-EISH-E17UC	OCL-0800-EISH-E8U7C	DSL-0800-UIDA-E50U
S3100A-4T450G/500P	ASL-1000-EISA-E12U	OSL-1000-EISA-E7U0	DSL-1000-UIDA-E40U
S3100A-4T500G	ASL-1200-EISA-E12U	OSL-1200-EISA-E5U8	DSL-1200-UIDA-E40U

Note: 1. × shown that Needless or Built-in.

2.S3100A-4T30G(or above) external DC reactor.

7.4 Input/Output Filter Specifications

Model	Input filter specifications (recommended)	Output filter specifications (recommended)
S3100A-2T0.4G	NF241B6/01	The single phase filter is regardless of input and output
S3100A-2T0.75G	NF241B6/01	
S3100A-2T1.5G	NF241B10/01	
S3100A-2T2.2G	NF241B10/01	
S3100A-2T4.0G	NFI-020	NFO-020
S3100A-2T5.5G	NFI-036	NFO-036
S3100A-2T7.5G	NFI-050	NFO-050
S3100A-2T11G	NFI-050	NFO-050
S3100A-2T15G	NFI-080	NFO-080
S3100A-2T18.5G	NFI-080	NFO-080
S3100A-2T22G	NFI-100	NFO-100
S3100A-2T30G	NFI-150	NFO-150
S3100A-2T37G	NFI-150	NFO-150
S3100A-2T45G	NFI-200	NFO-200
S3100A-2T55G	NFI-250	NFO-250
S3100A-4T0.75G/1.5P	NFI-005	NFO-005
S3100A-4T1.5G/2.2P	NFI-005	NFO-005
S3100A-4T2.2G/4.0P	NFI-010	NFO-010
S3100A-4T4.0G/5.5P	NFI-020	NFO-020
S3100A-4T5.5G/7.5P	NFI-020	NFO-020
S3100A-4T7.5G	NFI-020	NFO-020
S3100A-4T7.5G/11P	NFI-020	NFO-020
S3100A-4T11G/15P	NFI-036	NFO-036
S3100A-4T15G/18.5P	NFI-036	NFO-036
S3100A-4T18.5G/22P	NFI-050	NFO-050
S3100A-4T22G/30P	NFI-050	NFO-050
S3100A-4T30G/37P	NFI-080	NFO-080
S3100A-4T37G/45P	NFI-080	NFO-080
S3100A-4T45G/55P	NFI-100	NFO-100
S3100A-4T55G/75P	NFI-150	NFO-150
S3100A-4T75G/90P	NFI-150	NFO-150
S3100A-4T90G/110P	NFI-200	NFO-200
S3100A-4T110G	NFI-250	NFO-250

Model	Input filter specifications (recommended)	Output filter specifications (recommended)
S3100A-4T110G/132P	NFI-250	NFO-250
S3100A-4T132G/160P	NFI-300	NFO-300
S3100A-4T160G	NFI-300	NFO-300
S3100A-4T185G/200P	NFI-400	NFO-400
S3100A-4T200G/220P	NFI-400	NFO-400
S3100A-4T220G	NFI-600	NFO-600
S3100A-4T220G/250P	NFI-600	NFO-600
S3100A-4T250G/280P	NFI-900	NFO-900
S3100A-4T280G/315P	NFI-900	NFO-900
S3100A-4T315G	NFI-900	NFO-900
S3100A-4T315G/355P	NFI-900	NFO-900
S3100A-4T355G/400P	NFI-1200	NFO-1200
S3100A-4T400G/450P	NFI-1200	NFO-1200
S3100A-4T450G/500P	NFI-1200	NFO-1200
S3100A-4T500G	NFI-1200	NFO-1200



Soluciones
integrales en
Transmisión

E.R.H.S.A.
Girardot 1368 - C1427AKD
C.A. de Buenos Aires -Argentina
Tel. (011) 4554-3232 www.erhsa.com